

R E P O R T R E S U M E S

ED 014 423

SE 003 110

MICHIGAN SCIENCE CURRICULUM COMMITTEE JUNIOR HIGH SCHOOL
PROJECT. (TITLE SUPPLIED).

BY- VAN DEVENTER, W.C.

PUB DATE 67

EDRS PRICE MF-\$1.25 HC-\$11.76 292P.

DESCRIPTORS- *CURRICULUM DEVELOPMENT, *ECOLOGY, *INQUIRY TRAINING, *SECONDARY SCHOOL SCIENCE, *SCIENCE ACTIVITIES, *TEACHING METHODS, *UNIFIED SCIENCE, BIOLOGY, CONCEPT TEACHING, CHEMISTRY, EVALUATION, EARTH SCIENCE, EDUCATIONAL OBJECTIVES, GENERAL SCIENCE, GRADE 7, INSTRUCTIONAL MATERIALS, PHYSICAL SCIENCES, SCIENCE COURSE IMPROVEMENT PROJECT, TEACHING GUIDES,

REPORTED ARE THE RESULTS OF A CURRICULUM RESEARCH PROJECT OF THE MICHIGAN SCIENCE CURRICULUM COMMITTEE JUNIOR HIGH SCHOOL PROJECT FOR USE IN TEACHING JUNIOR HIGH SCHOOL UNIFIED SCIENCE. THE COMMITTEE USED PREVIOUS RESEARCH DATA, PARTICULARLY IN THE AREA OF INSTRUCTION AND INQUIRY TRAINING, TO DEVELOP 13 UNITS INCLUDING 55 OPEN-ENDED LABORATORY EXPERIENCES. EACH EXPERIENCE IS DIRECTED TOWARD ONE OR MORE OF 13 INTERDISCIPLINARY IDEAS WHICH ARE GROUPED UNDER TWO BASIC ASSUMPTIONS--(1) SCIENTISTS EXPECT NATURE TO BE DYNAMIC AND TO SHOW VARIATION AND CHANGE, (2) SCIENTISTS THINK OF THE WORLD, AND OF THE PHENOMENA IN IT, AS CONSISTING OF SETS OF RELATIONSHIPS RATHER THAN ABSOLUTES. EVALUATION WAS BASED ON STUDENTS' QUESTIONS SUBMITTED TO THE INSTRUCTOR AFTER THEY HAD COMPLETED INSTRUCTION RELATIVE TO A PARTICULAR IDEA. THESE QUESTIONS WERE THEN DIVIDED INTO TWO GROUPS, THOSE WHICH POINTED TOWARDS THE IDEA AND THOSE WHICH DID NOT. STUDENTS ALSO RESPONDED ON AN OBJECTIVE TEST WHICH REQUIRED THEM TO DISTINGUISH WHETHER A QUESTION DID OR DID NOT POINT TOWARD THE IDEA INVOLVED. FURTHER EVALUATION IS PROJECTED. THEY BELIEVE THAT THIS CAN BE USED, IN WHOLE OR IN PART, WITH ANY CURRICULUM PLAN SO LONG AS THE SUBJECT MATTER INCLUDED CAN BE MATCHED WITH ONE OR MORE OF THE IDEAS INCLUDED IN THE PROJECT MATERIALS. EACH OF THE 13 UNITS IS INCLUDED IN THE TEACHER'S GUIDE. CRITERIA FOR WRITING LABORATORY EXPERIENCES, SUGGESTED PROCEDURES FOR USING THE MATERIALS, AND THE TESTS DEVELOPED WITH THE PROJECT ARE ALSO INCLUDED. (DS)

ED014423

CE 003 110

U.S. DEPARTMENT OF HEALTH, EDUCATION & WELFARE
OFFICE OF EDUCATION

THIS DOCUMENT HAS BEEN REPRODUCED EXACTLY AS RECEIVED FROM THE
PERSON OR ORGANIZATION ORIGINATING IT. POINTS OF VIEW OR OPINIONS
STATED DO NOT NECESSARILY REPRESENT OFFICIAL OFFICE OF EDUCATION
POSITION OR POLICY.

Michigan Science Curriculum Committee Junior High School Project

(MSCC-JHSP)

Director:

Dr. W. C. Van Deventer
Department of Biology
Western Michigan University
Kalamazoo, Michigan 49001

Associate Director:

Mr. Jack Kammeraad
Michigan State Department of Education
Lansing, Michigan

1967

NOTE: This assembly of materials includes research which was per-
formed pursuant to a contract with the United States Department of
Health, Education and Welfare, Office of Education, under the provi-
sions of the Cooperative Research Program, and also includes items
prepared by the Committee prior to receiving federal support, published
in Bulletin No. 313, NDEA Title III, Open-Ended, Laboratory-Centered
Science for Grades 7-8-9, Michigan Department of Public Instruction,
Lansing, Michigan, 1965.

A New Approach to Interdisciplinary Seventh Grade Science

I
W. C. Van Deventer
Department of Biology
Western Michigan University

The Michigan Science Curriculum Committee Junior High School Project is an attempt to develop a program for seventh grade interdisciplinary science. It is based on selected cross-cutting ideas, and attempts to develop an understanding of these through open-ended laboratory experiences. So far thirteen ideas have been utilized, and fifty-five laboratory experiences directed toward these have been developed.

The investigators believe that junior high school science, particularly at its early levels, centering on seventh grade, constitutes a crucial, pivotal area, lying between the generalized science taught in the elementary grades, and specialized sciences of the secondary level. It furnishes a final opportunity to take a meaningful look at interdisciplinary science. This can best be done in terms of inquiry. The current failure of junior high school science to fulfill this vital, integrative function constitutes a problem that is the basis for this project.

The present trend toward offering lower level versions of single-field science courses in the junior high school complicates this problem rather than contributes to its solution. There is a definite place for a revitalized general science approach. This general science, however, needs to be planned in terms of problems, ideas, and understandings, rather than a limited survey of conventional science fields.

It is assumed in this investigation that students at the junior high level can and should begin to make meaningful contact with some of the ideas of science, and that these can best be taught through experiences that will enable them to see science as process and inquiry, rather than a body of facts to be learned.

The thirteen ideas have been selected on the following basis:

1. They are believed to be amenable for use at the junior high school level.
2. They can be approached through simple, open-ended laboratory experiences.
3. Once made a part of students' thinking, they will be useful at all later educational levels.

These ideas are grouped under two of the basic assumptions of scientists in dealing with the natural world:

- A. Scientists assume the universality of change.
 1. Idea of dynamic equilibrium
 2. Idea of change and variation
 3. Idea of normal curves and warping factors
 4. Idea of gradients
 5. Idea of extrapolation and interpolation
 6. Idea of cycles and cyclic change
 7. Idea of directional change in response to the challenge of the environment

- B. Scientists think in terms of relationships rather than absolutes
1. Idea of measurement as an expression of relationship
 2. Idea of templates or transference of pattern
 3. Idea of interdependence and interrelationship
 4. Idea of the necessary interaction of heredity and environment
 5. Idea of differential rates of processes in development
 6. Idea of tools, machines, and outside sources of energy as extensions of man's body and its capabilities

Fifty-five open-ended laboratory experiences have been developed, each directed toward one or more of the ideas. These experiences are simple, requiring little in the way of laboratory facilities or equipment. They are designed primarily to promote thinking on the part of the students.

The investigators have also developed a set of criteria for writing or evaluating laboratory experiences, and suggested procedures for teachers wishing to use the project materials. The materials have been tried out informally or with semi-supervision in a number of schools.

The project now faces the problem of attempting to evaluate students' thinking in relation to the ideas. The hypothesis presently being tested is that it is possible to determine more effectively the extent and quality of students' thinking in relation to an idea through the questions they ask than through the answers they give to questions asked of them.

The suggested teaching procedure encourages students to ask questions directed toward the ideas. These questions are asked orally prior to, during, and following the carrying on of laboratory experiences directed toward each idea. Questions are encouraged at four levels:

1. Those which can be answered readily from the experience at hand, together with general background knowledge
2. Those which can be answered, but only after considerable investigation and thinking
3. Those which probably cannot be answered by either student or teacher
4. Those which cannot be answered at all with our present state of knowledge, but which take students to the frontiers of research.

Finally, written questions at all of these levels are collected from the students. These are utilized to build testing instruments which ask students to distinguish between those questions that are related to the idea under consideration and those which are not so related. A more advanced type of test is projected which will attempt to determine why students make this distinction in the case of specific questions.

Those who are working with the project believe that they are striking at the heart of the inquiry process. The need now is for an opportunity to carry on these procedures under more careful supervision in the classroom.

The project materials may be obtained free by writing to:

Dr. W. C. Van Deventer
 Director, MSCC-JHSP
 Department of Biology
 Western Michigan University
 Kalamazoo, Michigan 49001

Suggested Procedure for a Teacher Wishing to

Use MSCC-JHSP Materials

1. Choose one or more of the Ideas. If you are using the materials for the first time it would probably be best to choose only one Idea, then after successfully completing this one, choose another if you wish to go ahead with the materials.
2. Choose those laboratory experiences under the Idea that you have selected which you feel are
 - a. within your own capabilities.
 - b. within the capabilities of your students.
 - c. within the range of possible accomplishment, given your situation.
3. Make sure that you yourself understand the Idea as it is expressed in the Idea-Bridge.
4. Communicate the Idea to your students in language that they can understand. This "translation" job is your responsibility. Furthermore, in doing it you will become better acquainted with the Idea yourself. Remember that students with different levels of ability may require different "translations." The Idea can be "translated" in some intellectually honest fashion for students at any ability level.
5. Take as much as a whole period in discussing the Idea with your students. Give them an opportunity to ask questions freely concerning it, and relating it to their past experiences.
6. Work out all of the laboratory experiences that you have chosen which look toward the Idea, one after another. As you do so, hold the Idea before the students by asking them leading, open-ended questions of your own devising which relate to the Idea. As far as possible, these questions should be "how-why" questions, rather than "what" questions or simple "how" questions. They should be framed at four different levels:
 - a. Some which can be answered readily by the student from general knowledge and the experience at hand.
 - b. Some which can be answered only after some thought and investigation.
 - c. Some which probably cannot be answered at all by either student or teacher.
 - d. Some which cannot be answered by anyone with our present state of knowledge, but which will show the students the frontier of the advance of science.

Note: Questions of types (a) and (b) tend to overlap; likewise, questions of types (c) and (d) necessarily do so.

7. Spend up to a whole period with the students, after the laboratory experiences are all completed, again going over the Idea in their language, and giving them an opportunity to ask questions freely, based on their laboratory experiences and pointing toward the Idea.
8. Ask the students each to write down six questions, pointed toward the Idea and based on their laboratory experiences. Three of these questions may be answerable by "Yes" or "No," and three may not be so answerable. (This is merely a device which we have found helps to give a broader "spread" to the questions that are asked.)
9. From the students' written questions, prepare two lists:
 - a. Those questions that in your best judgment apply to the Idea or point toward it.
 - b. Those questions that in your best judgment do not apply to the Idea or point toward it.
10. Select 25 or 30 of the "best" questions from each list, and scramble them into a two-choice objective test. Place at the beginning of the test a brief but clear statement of the Idea, so that students can refer to it while marking the test. Ask them to indicate which questions of the 50-60 listed apply to or point toward the Idea and which do not.

We believe that students give a better indication of their thinking in terms of an Idea by the questions that they ask than by any answers that they might give to questions which we would ask them.

It should be noted that this is not a "True-False" test. Both types of questions may be equally valid as questions, though it is not necessary that they be answerable. Some of them will be answerable and some may well not be. The distinction which the students are asked to make is made solely on the basis of whether or not the questions apply to or point toward the Idea.

Tests of this type do not constitute an attempt to evaluate the method of teaching in which they are used as compared to the conventional method or any other method. They are designed to evaluate only student thinking in relation to Ideas. Their use in no way precludes the use of additional tests designed to evaluate extent of factual knowledge, ability to solve problems, or any other objective.

MICHIGAN SCIENCE CURRICULUM COMMITTEE JUNIOR HIGH SCHOOL PROJECT (MSCC-JHSP)

Testing Program

The Michigan Science Curriculum Committee Junior High School Project has developed thirteen cross-cutting Ideas and fifty-six open-ended laboratory experiences which are based on these Ideas. At the present time MSCC-JHSP is interested in setting up a testing program to determine the extent to which students using these materials are attaining an understanding of the Ideas toward which the laboratory experiences are directed.

MSCC-JHSP believes that the questions students ask give a better indication of the quantity and quality of their thinking than any answers which they might give to questions that are asked of them. Therefore, a procedure is being tried in which testing instruments are prepared from questions that are asked by students in classes.

Would you or other members of your staff be interested in trying out some of the MSCC-JHSP materials, following the Project's Suggested Procedure, and participating in the experimental testing program?

MSCC-JHSP is prepared to enter into the following arrangement with those teachers who wish to take part in a cooperative program:

1. The cooperating teacher, after completing a series of laboratory experiences directed toward one of the Ideas, following the Suggested Procedure, will collect student questions and mail them to the Director of the Project.
2. The Director will process the questions into a test of the type described in the Suggested Procedure, and will mail the test to the teacher along with a master for grading.
3. The teacher may make any modifications in the test or the master that he thinks necessary, prepare mimeograph or dittoed stencils, and run off as many copies of the test as he needs.
4. After giving the test, the teacher will send to the Director:
 - a. a copy of the master and five copies of the test as he has given it, including any modifications that he has made in either.
 - b. the raw test scores from the class(es) in which he used the test, and any analysis of these that he has made.
5. The Director will send the teacher any new materials that may be produced by the Project, and the results of any testing program that is developed.

11

Michigan Science Curriculum Committee Junior High School Project
(MSCC-JHSP)

Director: Dr. W. C. Van Deventer
Department of Biology
Western Michigan University
Kalamazoo, Michigan 49001

Associate Director: Mr. Jack Kammeraad
Michigan State Department of Education
Lansing, Michigan

1967

NOTE: This assembly of materials includes research which was performed pursuant to a contract with the United States Department of Health, Education and Welfare, Office of Education, under the provisions of the Cooperative Research Program, and also includes items prepared by the Committee prior to receiving federal support, published in Bulletin No. 313, NDEA Title III, Open-Ended, Laboratory-Centered Science for Grades 7-8-9, Michigan Department of Public Instruction, Lansing, Michigan, 1965.

Directing Inquiry Toward Cross-Cutting Ideas in Science
Through the Use of Simple, Open-Ended Laboratory Experiences

Michigan Science Curriculum Committee
Lansing, Michigan

I. Teaching Unified Science in Terms of Cross-Cutting Ideas

The Michigan Science Curriculum Committee¹, operating under the Michigan State Department of Education, has been concerned with the development and testing of curricular materials for use in the junior high school, particularly in seventh grade. Junior high school science, especially at its early levels, constitutes a crucial, pivotal area, lying between the generalized science taught in the elementary grades, and the specialized sciences of the high school years. It furnishes a final opportunity to take a meaningful look at interdisciplinary science. The current failure of junior high school science to fulfill this vital integrative function constitutes the problem which is the basis for this project.

The present trend toward offering lower level versions of single-field science courses in the junior high school complicates this problem rather than contributes to its solution. There is a definite place for a revitalized general science approach. This general science, however, needs to be planned in terms of problems, ideas, and understandings, rather than a limited factual survey of conventional science fields.

Renner (1963) says that "student understanding of the work of a scientist decreases as he progresses through the junior high school." It is assumed in this project that students at the junior high level can and should begin to make meaningful contact with some of the ideas of science, and that these can best be taught through experiences which will enable them to see science as a process of inquiry, rather than merely a body of facts to be learned.

The Committee believes that it is possible to select ideas or understandings of a cross-cutting nature, important for two or more fields of science, which can be introduced at the level of the junior high school, and which will continue to be valid in progressively more sophisticated fashion at each succeeding educational level. The junior high school science program can then be built around a limited number of such ideas, as many as can be dealt with adequately in the time available.

They believe, furthermore, that the experiences which will prove most fruitful in developing ideas of this kind are those involving open-ended laboratory. For these, students should be given minimal directions, mainly of a procedural nature. While carrying on these experiences they should be guided by questions at various levels of difficulty, asked either in connection with the written directions or by the teacher. They

¹This Committee consists of representatives of state universities, public schools (administrators, science supervisors, and teachers at various levels) and industry.

should also be encouraged to raise questions at all levels, not all of which need necessarily be answerable. All questions, whether in the directions or asked by teacher or students, should be pointed toward the idea toward which the laboratory experience is directed.

It is recognized that this approach involves a clear departure from conventional learning design. Subject matter is introduced as necessary in connection with the laboratory experiences, and becomes important only in terms of the ideas or understandings to which it contributes. This differs from subject matter-centered learning in which the acquisition of knowledge is an end in itself, and the laboratory experiences are primarily illustrative. It differs also from the purely exploratory type of laboratory in which the activities are considered worthwhile as ends in themselves.

In the type of learning proposed here, the ideas to be taught must be made clear to the students, and kept before them while the study is going on. In order that this may be done, it is necessary that a clear statement of each idea be prepared and made available to the teacher. It is then the teacher's responsibility to translate the idea into student language, and keep it before the students. In doing this the teacher not only makes the idea intelligible to the students, but also makes it a part of his own thinking.

The problem, therefore, has involved:

1. Selecting ideas or understanding that cut across two or more fields of science, and that will be significant at all educational levels beyond the point at which they are introduced.
2. Preparing clear statements of these ideas.
3. Selecting open-ended laboratory experiences that will contribute to the ideas.
4. Setting up outline directions for these experiences.
5. Using the experiences in the classroom, revising them if and as necessary.
6. Evaluating growth in student thinking as a result of the experiences, in terms of the ideas toward which they are directed.

Studies on the principles of science have constituted a major area of investigation in science education since the publication of the Thirty-First Yearbook (1932). Blanchet (1957) listed twenty-four studies which he considered outstanding, including a study by Smith (1951) of principles desirable for a course in junior high school general science. He indicated, however, that approximately twice this number had been carried out at the time he published his summary. Van Deventer (1956) showed that subject matter principles, of the type identified by Blanchet and others, rest on the facts of science, and in turn, furnish support for ideas or understandings of a broad nature which may belong to a single field of science, or may cut across two or more fields. He called these "area principles." He also demonstrated (1955) that there are a limited number of basic assumptions that are common to all science.

The "ideas" which are used in the present study are similar to the "area principles" defined in Van Deventer's 1956 study. A close affinity to these ideas is found in the nine "themes" on which the Biological Sciences Curriculum Study (BSCS) is based. Similar ideas or understandings can be identified in other major curriculum studies: the Physical Science Study Committee (PSSC), the Chemical Bond Approach (CBA), the Elementary Science Study (ESS), the Science Curriculum Improvement Study (SCIS), and the School Science Curriculum Project (SSCP). Some of the "processes" of the Process Approach of the AAAS Commission on Science Education also exhibit a similar affinity.

The Michigan Science Curriculum Committee Junior High School Project (MSCC-JHSP) has developed thirteen units, including a total of 55 open-ended laboratory experiences. Each unit is directed toward a specific cross-cutting idea. The ideas are grouped under two of the basic assumptions of scientists in dealing with the natural world (Van Deventer, op. cit.):

- A. Scientists assume the universality of change:
 1. Idea of dynamic equilibrium
 2. Idea of change and variation
 3. Idea of normal curves and warping factors
 4. Idea of gradients
 5. Idea of extrapolation and interpolation
 6. Idea of cycles and cyclic change
 7. Idea of directional change in response to the challenge of the environment

- B. Scientists think in terms of relationships rather than absolutes:
 1. Idea of measurement as an expression of relationship
 2. Idea of templates or transference of pattern
 3. Idea of interdependence and interrelationship
 4. Idea of the necessary interaction of heredity and environment
 5. Idea of differential rates of processes in development
 6. Idea of tools, machines, and outside sources of energy as extensions of man's body and its capabilities

It is not the thought of the investigators that these thirteen ideas are the only ones available, or even necessarily the most worthwhile ones. No attempt has been made to determine how many such ideas there are, and no such study is contemplated. The intent of the Committee has been to choose ideas which are amenable to the objectives of the study, and which exhibit a meaningful relationship to one another.

Showalter (1964) describes an experimental program in unified science in the Ohio State University School which is based on the teaching of ideas or concepts of the same type as those used in the present study. Schultz (1961) describes an experiment in which the ideas of community ecology were taught successfully to second and sixth grade children. Atkin (1961) describes the teaching of some of the concepts of modern astronomy to elementary school children. The work of Karplus in the Science Curriculum Improvement Study has involved teaching some of the ideas of modern physics at the early elementary level. Jerome Bruner holds that "any subject can be taught effectively in some intellectually honest form to any child at any stage of development." The present study has proceeded on the assumption that relatively sophisticated ideas of science can be taught at the junior high school level, and earlier, if:

- (1) They can be communicated to students in language that they can understand, and
- (2) They can be related to experiences which are meaningful to students.

II. Using Inquiry Procedures

All of the modern curriculum studies list as an objective the teaching of science as inquiry. Open-ended laboratory is a part of inquiry but by no means all of it. Science is not a set of facts to be learned, nor even a list of problems to be solved. It is rather an attitude of learning through inquiring. Sometimes problem-formulating is more important for the process of inquiry than problem-solving.

The literature in science education includes various uses and definitions of the term "inquiry." Alfred Novak (1964) says, "Inquiry is the total configuration of behaviors involved in the struggle of human beings for reasonable explanations of phenomena about which they are curious." Rutherford (1964) distinguishes between "inquiry as content," and "using the method of scientific inquiry to learn some science," which he calls "inquiry as technique." He says, "If all that is intended by the inquiry method is that we should encourage a student to be inquisitive, curious, to ask questions, and to try to find answers for himself, then we are advocating no more than what good teachers have long believed in and practiced."

J. R. Suchman, in telling about the Illinois Project in Inquiry Training described inquiry as the "act of creating individual knowledge by gathering and processing information." Fish and Goldmark (1966) add that "the process of inquiry which Suchman has structured is a process of formulating theories and testing them through experimenting and data gathering."

Neal (1961) in describing a study of techniques for developing scientific inquiry in elementary school children, says, "The study indicated that children's interest in science were developed as a result of the direct approach of teaching the methods of scientific inquiry." Gagne (1963) although he holds that true inquiry should not be expected to take place until about the third year of college, after a thorough grounding in the processes and principles of science, defines inquiry as "a set of activities characterized by a problem-solving approach, in which each newly encountered phenomenon becomes a challenge for thinking."

In connection with the Biological Sciences Curriculum Study, which lists "Science as Inquiry" as one of the nine themes around which subject matter and laboratory experiences are integrated, Schwab (1963) says, "The essence of teaching science as inquiry would be to show some of the conclusions of science in the framework of the way they arise and are tested." In relation to laboratory experiences, he says, "They are not illustrative but investigatory. They treat problems for which the text does not provide the answers. They create situations in which the student may participate in the inquiry."

Strasser (quoted by Fish and Goldmark, op. cit.), in presenting his view of inquiry, says that "the kinds of questions we use determine the kinds of operations the children will perform. The questions we use outline the kinds of thinking, observing, and other behaving responses of the learners for which we, their teachers, search." He suggests that we examine our teaching to see if we ask students only questions which demand recall, or only those which call for our answers. Do we ask a variety of kinds of questions that stimulate a range of behaviors which may be identified as aspects of "sciencing"?

Since the laboratory experiences in the present study are open-ended, they in themselves involve a kind of inquiry. The investigators believe, however, that the heart of the inquiry process lies in the questions that are asked. They define inquiry as the approach to an idea by students and teacher through questions asked of each other at various levels of difficulty. They believe that questions should be asked (and permitted) at all levels:

1. Those which can be answered readily from the experience and materials at hand, together with general knowledge.
2. Those which can be answered, but only after considerable investigation and thinking.
3. Those which cannot be answered by either students or teacher.
4. Those which probably cannot be answered at all with our present state of knowledge.

The investigators believe that much of the conventional educational process tends to stifle inquiry on the part of students rather than nurture it. Much of the natural curiosity of children during the elementary years is destroyed through emphasis on specific knowledge given in answer to questions, and consequently on the asking only of those questions that can be answered. This is true both of the questions which we ask students, and also of the questions which we allow them to ask us.

Emphasis on the retention of knowledge as an end in itself fosters this limitation. Teachers ask students questions which hopefully they can answer, and to which the teacher knows the answer. Questions that the teacher cannot answer, and which perhaps no one can, do not generally lead to approval when they are asked by students. Such questions are viewed, at best, as being useless or leading nowhere, and at worst, as an attempt on the part of students to lead the teacher astray from the prescribed work of the course.

Yet it is these unanswered, and sometimes unanswerable questions which form the heart of the inquiry process. It is at this point that the teacher can say, "I don't know the answer, and I doubt if anyone else does. We can look for the answer, collect evidence, and possibly make a judgment as to what the answer might be, but we cannot be sure. This is research!"

Only by maintaining this questioning attitude as an approach to the materials and experiences of science can students be led to develop a research attitude, and a feeling of being on the frontier of the advance of knowledge.

The investigators believe that the laboratory experiences which have been developed, simple in themselves, but constructed for open-ended procedure and guided with questions pitched at the four levels indicated above, constitute ideal vehicles for use by teachers and students in carrying on inquiry with relation to the specific ideas toward which they are directed.

The approach which is being used in this project, even though it involves open-ended laboratory experiences, is only partially inductive. The students must know where they are going. Before this can happen, the teacher must have the idea-goal clearly in mind, and must keep it in mind. The idea must be kept before the students while the experiences are in progress. Unless this is done, the laboratory experiences become nothing more than interesting, gadgety activities of the type with which the literature published at the junior high school and upper elementary levels is already well-filled.

The student needs to learn at an early level that science does not have all the answers, or at least has not yet learned them, and that the process of learning them is still going on. Answers are generally less important anyway than the process by which the student arrives at them. He should be accorded the privilege of arriving at a wrong answer while seeking for a right one. Mistaken conclusions are more easily corrected than faulty methods, and when a student is told the right answer, or is able to look it up in a textbook, this is not really science at all.

The laboratory experience outlines which have been prepared have been kept simple. The investigators believe that laboratory experiences should utilize as simple and easily obtainable equipment as possible. This is not because equipment and know-how for more complex experiences are unavailable. In many cases the opposite is true. There is no virtue in the use of elaborate equipment, however, as an end in itself. If a simple laboratory experience will lead to a significant idea as well as a complex one, the simpler one should be used. The understanding to be attained is the important goal, not the experience itself. All laboratory experiences should be tested for value in terms of the ideas that they produce.

Laboratory procedure should always involve the recording and interpretation of data, which, so far as possible, should be based on weighing, measuring, counting, or some other type of quantitative determination. Mathematical treatment, like the use of elaborate equipment, involves the possibility of becoming an end to be pursued for its own sake rather than a means to an end.

A teacher's success in using the materials which have been prepared by the project depends in large part on his own resourcefulness and originality. The ideas toward which the experiences are pointed will not teach themselves. They must be set forth and explained. Contributory subject matter from textbooks and other sources must be supplied, and its use encouraged. Feedback from the students must be sought for and utilized constantly for improvement of teaching.

III. Evaluation of Students' Thinking in Relation to Ideas

Smith (1963), in reviewing educational research related to science instruction for the elementary and junior high schools, noted the relative scarcity of evaluation studies at these levels, and indicated that inadequate research in the area of evaluation constitutes a major problem in elementary and junior high school science at the present time. This lack is particularly apparent in connection with the modern curriculum study projects.

Hurd and Rowe (1964), reviewing recent research in science teaching in the secondary school, reported several studies showing that, insofar as the courses based on the modern curriculum studies are directed toward goals different from those of conventional courses, student achievement in them can be measured adequately only by using instruments designed specifically for them. Cooley and Klopfer (1963) pointed out the necessity of including the selection or development of testing instruments for measuring the specific objectives of new approaches in any research on the results obtained from using these approaches. Trump (1964) said that the use of conventional standardized tests and teacher-made tests often fails to differentiate meaningfully between new and conventional educational procedures.

Atkin (1963) discussed some of the problems of evaluation which arise in connection with the development of new curriculum materials. He stated that new approaches to learning, and the materials and activities appropriate for teaching them, must first be identified, then tried out in classroom situations. Informal evaluation of the new approaches and materials must be carried on continually by those using them, in terms of the behavior of students in relation to them. Only when this has been done can adequate evaluation instruments be constructed and used effectively. These instruments may well need to be based on new and broader concepts of evaluation than those which generally have been utilized in classical educational research.

In the present study, the investigators have followed the procedure that Atkin outlined. Materials have been developed which it is believed will contribute to the objectives of the project. These have been tried out in the classroom. On the basis of the results which have been obtained, a theory of evaluation has been tentatively put forward, and preliminary testing instruments have been constructed and tried.

Cooley and Klopfer (op. cit.) make the following statement: "In constructing a new test, the specification of the student outcomes to be measured is by far the most difficult task. This is especially true if the desired outcomes are other than the recall or application of subject matter content. However, if the innovation work is properly conducted, the development of new instruments is not so difficult as it might seem. The original statements of desired student behaviors can be used as the basis for writing test items also."

The investigators are not concerned at this point with measuring the acquisition or retention of factual knowledge, although they recognize its importance, and there are informal indications that learning in this area is considerable. They are concerned with finding a way to determine the extent and quality of the students' thinking in relation to the cross-cutting ideas toward which the laboratory experiences are

directed. They believe that the questions which students ask give a better indication of their thinking than any answers which they might give to questions that are asked of them.

A teacher using the MSCC-JHSP materials is asked to select an idea which can be fitted into the particular science course that he is teaching, then to choose laboratory experiences directed toward this idea which are within his own capabilities, within his students' capabilities, and within the limits of possible accomplishment, given his teaching situation.

The teacher must now be certain that he understands the idea himself. Each of the ideas is explained in an extended statement called an "Idea-Bridge." This is a device for communicating to the teacher the meaning of the idea which the investigators intended. When the teacher has made the idea a part of his own thinking, he must communicate it to the students in language that they can understand.

The laboratory experiences are then worked out by the students, with the teacher holding the idea before them while this is being done. During this time, inquiry is taking place in the form of questions at all levels, asked of each other by students and teacher.

When class consideration of the idea, and laboratory experience with it, are completed, each student is asked to write down a limited number of questions (usually three to six), which, in his judgment, are related to the idea, and based on the laboratory experiences. From the students' written questions, the teacher then prepares two lists: (1) those questions which in his judgment apply to the idea or point toward it, and (2) those which do not do so.

Twenty-five to thirty questions are chosen from each list. All of these are valid questions, but they are as clearly differentiated as possible on the basis of their relationship or lack of relationship to the idea. These fifty to sixty questions are then scrambled into an objective test, offering the student two choices: the question does or does not point toward the idea. A brief, but clear statement of the idea is placed at the beginning of the test, and students are asked to refer to this, and evaluate each question in terms of it.

It should be noted that this is not a "true-false" test. Questions of both types are equally valid as questions, though it is not necessary that they be answerable. Some of them will be answerable and some may well not be. The distinction which the students are asked to make is made solely on the basis of whether or not the questions apply to or point toward the idea.

Tests of this type do not constitute an attempt to evaluate the method of teaching in which they are used, as compared to the conventional method or any other method. They are designed to evaluate only student thinking in relation to ideas. Their use in no way precludes the use of additional tests designed to evaluate extent of factual learning, ability to solve problems, or any other objective.

It is anticipated that later tests will be so constructed that the student will be asked to make a further choice of answers to indicate why he considers that a particular question is or is not related to the idea. Still other possibilities of giving added dimensions to the tests, with further probing of student thinking, may well become apparent as the study progresses.

The investigators plan also to look for possible correlations of the results of these tests: (1) with one another, to see if student behavior with relation to a series of tests of the same type is consistent; (2) with standard intelligence tests, to see if what we are measuring is related to general ability; and (3) with tests for subject matter retention, problem solving ability, interest in science, and any other measurable characteristics concerned with science.

IV. Use of the Materials

The investigators do not consider that they have, at the present time, a package course in junior high school general science. They do not have any intention of developing their work in this direction. They have, instead, what they believe to be a new way of teaching science at the general level. They believe that this can be used, in whole or in part, with any curriculum plan, so long as the subject matter included in the plan can be matched up with one or more of the ideas included in the project materials. The ideas and their related laboratory experiences are being used in this way in the schools where they are being tried. Teachers who are using them report favorably on the degree of freedom which this kind of use makes possible. They find this especially true in comparison with the "package" courses offered by many other curriculum studies.

Although some of the materials of the project have been used successfully in sixth grade, and some in eighth, they have been used most extensively and most successfully in seventh grade, the level for which they have been primarily designed. All of the outlines for the laboratory experiences have been edited for reading level by an experienced seventh grade teacher, who has been one of the investigators from the beginning of the project. The Idea-Bridges have not been so edited, since they are written for the teacher, whose job it is to present the idea to the students in language that they can understand. Other materials of the project: Criteria for Writing or Evaluating Laboratory Experiences, Suggested Procedure for Teachers Wishing to Use MSCC-JHSP Materials, and Directing Inquiry Toward Cross-Cutting Ideas in Science Through Simple, Open-Ended Laboratory Experiences, are also directed toward the teacher.

Bibliography

1. Atkin, J. Myron, "Teaching Concepts of Modern Astronomy to Elementary School Children." Science Education 45:54-58, February 1961.
2. Ibid., "Some Evaluation Problems in a Course Content Improvement Project." Journal of Research in Science Teaching 1:129-132, Issue 2, 1963.
3. Blanchet, Waldo W. C., "Principles of Science: A Look Ahead." Science Education 41:1-9, February 1957.
4. Bruner, Jerome, The Process of Education. Harvard University Press, Cambridge, Mass., 1960.
5. Cooley, William W., and Leopold E. Klopfer, "The Evaluation of Specific Educational Innovations." Journal of Research in Science Teaching 1:73-80, Issue 1, 1963.
6. Fish, Alphoretta S., and Berenice Goldmark, "Inquiry Method: Three Interpretations." The Science Teacher, 33:13-15, February 1966.
7. Gagne, Robert M., "The Learning Requirements for Inquiry." Journal of Research in Science Teaching 1:144-153, Issue 2, 1963.
8. Hurd, Paul deHart, and Mary Budd Rowe, "Science in the Secondary School." Review of Educational Research 34:286-297, June 1964.
9. Karplus, Robert, "The Science Curriculum Improvement Study." Journal of Research in Science Teaching 2:293-203, Issue 4, 1964.
10. National Society for the Study of Education, A Program for Teaching Science. Thirty-first Yearbook, Part I. Public School Publishing Company, Bloomington, Illinois, 1932.
11. Neal, Louise A., "Techniques for Developing Scientific Inquiry in Grades One Through Six." Science Education 45:313-320, October 1961.
12. Novak, Alfred, "Scientific Inquiry." Bioscience, 14:25-28, October 1964.
13. Renner, John W., "Science, Engineering and Technology as the Junior High School Student Understands Them." Journal of Research in Science Teaching 1:89-94, Issue 1, 1963.
14. Rutherford, F. James, "The Role of Inquiry in Science Teaching." Journal of Research in Science Teaching 2:80-84, Issue 2, 1964.
15. Schultz, Beth, "The Use of Ecology in Teaching Science to Children," Science Education 45:97-113, March 1961.
16. Schwab, Joseph J., Biology Teacher's Handbook: Biological Sciences Curriculum Study. John Wiley and Sons, New York, 1963.
17. Smith, Herbert A., "A Determination of Principles Desirable for a Course of General Science at the Junior High School Level." Science Education 35:279-284, December 1951.

18. Ibid., "Educational Research Related to Science Instruction for the Elementary and Junior High School." Journal of Research in Science Teaching 1:199-255, Issue 3, 1963.
19. Showalter, Victor, "Unified Science: An Alternative to Tradition." Science Teacher 31:24-26, February 1964.
20. Suchman, J. Richard, Illinois Studies in Inquiry Training. Mimeographed article describing research sponsored by the Office of Education, U.S. Department of Health, Education, and Welfare, and by the Research Board of the University of Illinois.
21. Trump, J. Lloyd, "Some Problems Faced in Organizing Science Teaching Differently." Science Teacher 31:37-39, May 1964.
22. Van Deventer, W. C., "The Teaching of Basic Premises as an Approach to Science in General Education." Science Education 39:389-398, December 1955.
23. Ibid., "The Use of Subject Matter Principles and Generalizations in Teaching." School Science and Mathematics 56:466-472, June 1956.
24. Ibid., "Laboratory Centered Science Teaching." Metropolitan Detroit Science Review 24:105-107, September 1963.
25. Ibid., "Michigan Prepares Project on Junior High Science." The Science Teacher 31:29-30, November 1964.
26. Ibid., "New Horizons in Curriculum Development." Newsletter of the Michigan Science Teachers Association 13:(3)11-18, February 1966.
27. Ibid., "Toward a 'Comparative Anatomy' of the Curriculum Studies." Science Education 50:196-203, April 1966.
28. Ibid., "Michigan Science Curriculum Committee Junior High School Project (MSCC-JHSP)." Newsletter of the Michigan Science Teachers Association 13:(6)10-14, June 1966.
29. Ibid., "New Developments in the Sciences for Elementary and Secondary Schools." Michigan School Board Journal 13:(5)12-13 and 22-23, July 1966.
30. Open-Ended Laboratory-Centered Science for Grades 7-8-9. Committee on Science of the Michigan Cooperative Curriculum Program, NDEA Title III, Bulletin No. 313. Michigan Department of Public Instruction, Lansing, Michigan, 1965.

Criteria for Writing Laboratory Experiences

A. Ideally laboratory experiences should:

1. be open-ended. Students should not be able to find answers by reading only, although the information so found should be helpful, and may well suggest possible answers. More than one correct or acceptable answer may well be possible.
2. look toward a specific idea or understanding. This idea should be either clearly stated or readily apparent. Unless laboratory experiences can be so directed, they are probably a waste of time.
3. give as few directions as possible except for necessary procedural ones. As far as possible, the information necessary for the experience should be derived from the experience itself. Only in this way can the "research approach" be made real to the student.
4. mainly ask questions, including:
 - a. some which can be answered readily from the experiences at hand, together with general knowledge.
 - b. some which can be answered only after considerable investigation and thinking.
 - c. some which cannot be answered with certainty by either student or teacher.
 - d. some which probably cannot be answered by anyone with our present state of knowledge, but which will show the student the frontier of the advance of science.

Answers are generally less important than the process by which the student arrives at them. The student should be accorded the privilege of arriving at a wrong answer while seeking for a right one. Mistaken conclusions are more easily corrected than faulty methods, and when a student is told the right answer or is able to look it up in a textbook, the entire purpose of laboratory work as a problem formulating and problem solving operation has been bypassed.

B. To be effective, laboratory experiences must be:

1. within the capabilities of the teacher
2. within the capabilities of the students, and
3. within the limits of possible accomplishment, given the laboratory or field situation.

They should utilize as simple, easily obtainable and inexpensive equipment as possible. There is no virtue in the use of elaborate equipment as an end in itself. If a simple laboratory experience will lead to a significant idea as readily as a complex one, the simpler one should be used. All laboratory experiences should be tested for value against the ideas which they will produce.

- C. Laboratory procedure should always involve the recording and interpretation of data, which, so far as possible, should be based on weighing, measuring, counting, or other type of quantitative determination. Mathematical treatment, however, should be kept as simple as possible. Simple percentages and graphs often tell a more effective story than expressions of complex mathematical relationships. Mathematical treatment, like elaborate equipment, involves the possibility of becoming an end to be pursued for its own sake rather than a means to an end.

III

The material included in the Michigan Science Curriculum Committee Junior High School Project (MSCC-JHSP) consists of fifty-five open-ended laboratory experiences, each of which is directed toward one or more of thirteen interdisciplinary ideas. These ideas are grouped under two of the basic assumptions which scientists make in dealing with the natural world*:

Basic Assumption A: Scientists expect nature to be dynamic rather than static, and to show variation and change.

Basic Assumption B: Scientists think of the world, and of the phenomena in it, as consisting of sets of relationships rather than absolutes.

*Van Deventer, W. C., "The Teaching of Basic Premises as an Approach to Science in General Education." Science Education 39:389-398, December 1955.

A. Scientists assume the universality of change:

1. Idea of dynamic equilibrium
2. Idea of change and variation
3. Idea of normal curves and warping factors
4. Idea of gradients
5. Idea of extrapolation and interpolation
6. Idea of cycles and cyclic change
7. Idea of directional change in response to the challenge of the environment

Idea of Dynamic Equilibrium

1. **Idea-Bridge: "Thinking About Dynamic Equilibrium--Nothing Really Stands Still"**
2. **Laboratory Experiences:**
 - a. "Internal Equilibrium: Maintenance of Weight in Humans"
 - b. "Equilibrium in the Landscape: Erosion, Drainage Patterns, and Valley Formation"
 - c. "Chemical Indicators: A Simple Case of Equilibrium"
 - d. "Measurement as an Expression of Relationship: A Simple Balance"
 - e. "A Study of Interrelationships: The Balanced Aquarium and the Pond Infusion Culture"
 - f. "Theories of the Origin of the Universe: Two Approaches to Dynamic Equilibrium"

Thinking About Dynamic Equilibrium: Nothing Really Stands Still

When we think of equilibrium we usually think of a balance, in which the forces or processes that are operating against one another are exactly equal, so that no change occurs. There are many examples of such situations, but they are generally the result of a series of adjustments, of "coming to balance". Most of them do not remain constant for very long at a time. None of them are permanent, not even those that appear to remain unchanged for long periods.

We live in a world of unending change. The factors of the environment that surround any condition of temporary balance are usually so inconstant that the state of balance, insofar as it is ever reached at all, is continually being disturbed. There is a constant state of coming to balance". This is what we mean by "dynamic equilibrium".

There are many common examples of dynamic equilibrium: 1.) a laboratory balance where the indicator has finally come to rest at the zero point, then is disturbed by every passing vibration and has to come to rest again; 2.) a climax forest developing on an abandoned field after long years of growth and ecological succession, then varying around a state of equilibrium with the changing conditions of the seasons, of wet and dry summers, of mild and cold winters, and other environmental fluctuations; 3.) a living organism maintaining a state of internal equilibrium (homeostasis) as a result of the interacting forces of build-up (anabolism) and breakdown (catabolism) in the internal environment; 4.) the features of the earth's surface and the bodies in the universe where processes of adjustment and the conditions resulting from their operation take place more slowly and are longer lasting. On a short term or a long term basis, all of the natural world exhibits equilibrium which is dynamic rather than static.

How many other examples of dynamic equilibrium can you think of? Students should read about processes in the natural world (living and physical) and find as many examples as possible.

Internal Equilibrium: Maintenance of Weight in Humans

Introduction:

Modern people are very conscious of weight. This is true especially of adults, but children also may be overweight or underweight. Weight is a factor not only of health but also of personal appearance. A condition of overweight or underweight may be either an indication or a cause of ill health.

What is called "normal weight" is really average weight for persons of a particular age, height, and sex. If enough persons belonging to a particular age-height-sex group were measured, and the measurements were plotted in the form of a frequency distribution on a graph, the result would be a normal curve. The mode of this curve, which would also be the mean of the sample, would be the normal weight. Some deviation is allowed, forming a range of normalcy on either side of the mean.

Growing children, of course, are slowly increasing in weight throughout their period of development, although the rate of increase is not constant. Throughout mature adulthood, while there are slow changes with increasing age, a balance is normally maintained. With the onset of old age, these changes may become somewhat more extensive. In periods of ill health, rapid changes in weight, either loss or gain, may indicate serious internal maladjustment or illness.

We may think of the period of growth in early life as being the time during which the building-up processes (anabolism) operate in excess of the tearing-down processes (catabolism). During healthy adulthood, the anabolic and catabolic processes are essentially in equilibrium, and a balance (homeostasis) is maintained. In old age, the catabolic processes generally outweigh the anabolic processes. This may or may not be reflected in body weight.

When people diet to lose weight, they reduce their intake of energy-producing foods (carbohydrates and fats) and their total food intake below the amount necessary to maintain the body. Some of the body's stored fat (representing weight that has accumulated) is then oxidized to make up the difference. Thus weight is lost, until ultimately it is allowed to stabilize at the desired level. It is then maintained at this level through carefully controlling food intake at the point of maintenance.

Materials and Equipment:

Bathroom scales

Graph paper

Procedure:

1. Record the weight of one or more adults, and one or more children, taken at the same time each day, over a period of at least three months. Plot the daily weight on sheets of graph paper which can be fastened together end-to-end to make a continuous story.
2. Try to find an adult who is attempting to lose weight by dieting, and record this person's daily weight for the same period, and in the same way.
3. If a number of individuals or teams in the class are carrying on this laboratory experience at the same time, pool the results of all of them. Get as many weight records of adults and children, dieters and non-dieters, as possible. Compare them.
4. To what extent is homeostasis maintained? In adults? In children? In men? In women? In boys? In girls? In dieters? In non-dieters? To what extent does fluctuation occur? Are the dieters able to lose weight consistently? To what extent? Is there any evidence of progressive slow increase in weight in the children? If so, to what extent is the rate of increase constant?
5. To what extent is there evidence in your study of equilibrium between anabolic and catabolic processes? What are the anabolic and catabolic processes that are involved? Does heavier eating on holidays and weekends make a difference? Does this difference appear in the records of all individuals or only in some? Why? Are any rhythms apparent? Are they similar or comparable in all individuals? Why or why not?

Further Considerations:

Find out all you can about current trends in the sales of diet foods, non-caloric sweeteners, calorie-free soft drinks, animal and vegetable fats (butter and margarine, lard and cooking oils). How are these related to current popular fears of the relationship of overweight to heart disease and other health dangers?

Weight is one indicator of homeostasis or equilibrium of body functions. Can you think of others?

Equilibrium in the Landscape: Erosion, Drainage Patterns and Valley Formation

Introduction:

Through the operation of unbelievably slow processes in geological time, layers of sediment that have been deposited in shallow seas are raised up to form new mountains. At what rate does this take place? Then through correspondingly slow processes, these mountains are worn down to a level or peneplain. How can you tell new mountains from old ones? What are some examples of each in our present-day world?

Although these geological processes proceed very slowly, such that only their long-term effects can be observed at any one period of the earth's history, it is possible to observe small-scale, man-made models of the process of gradation going on around us all the time. Everyone has observed eroded fields and roadsides. Small, temporary streams behave exactly like larger creeks and rivers, and the valleys that are cut by such small, temporary streams go through the same developmental stages as larger valleys.

We can learn a great deal about the history of the landscape by observing an eroded field or a pile of dirt after a heavy rain.

Materials and Equipment:

Piles of dirt, usually observable around construction projects, at various stages of age and erosion.

Eroded areas along a newly constructed highway and/or in a field.

A relief model or map of North America.

Travel through the country with an observant eye.

Procedure:

1. Observe a freshly-made pile of dirt at a construction project immediately after a heavy rain. Note the stream channels down its sides. What is the shape of the channels in cross-section? Why? Note the sediment that has been deposited on the surface of the ground at the mouth of each stream channel. What is the shape of the deposit? Why is it called an alluvial fan? What is the character of the particles of dirt that make up the deposit? Compare them with the original pile from which they came. Are there any differences? What are these differences? Why? Does the kind of soil make any difference? What and why?
2. Observe the same or a similar pile of dirt after it has been eroded by many rains. Compare the extent, shape, and general appearance of the stream channels in this pile with those made by a heavy rain in freshly-piled dirt. What differences do you see? Why? Make a

similar comparison of the deposits at the mouths of the stream channels on its sides. What differences are there? Why?

3. If possible, observe the effects of erosion on a very old pile of dirt. Make the same comparisons as before.
4. Observe the results of erosion along the right-of-way of a freshly-constructed highway, and/or on a hillside in a field. Compare what you see there with what you observed on the piles of dirt. Make comparisons similar to those which you have made before. Can you determine the age of the erosion in a field or a road cut by a study of the stream channels and alluvial fans? Is there any evidence in the case of the field that some of the erosion is more recent, and some older? What is the evidence?
5. Study a relief model or a relief map of North America. What do you see that can be related to what you observed on the dirt piles, along the highway, or in the field? What would you say about the age of the ranges of mountains on the map? Why?
6. What is the history of a stream valley as it grows older? How can you tell the relative age of a valley? Have you ever observed young valleys as you traveled through the country? Where? Old valleys? Where? What is a peneplain? Are there any peneplains in North America? If so, where? How do we know that they are peneplains? How old are they, geologically? What is the relationship of a peneplain to the attainment of equilibrium on the earth's surface?
7. What can you say about the attainment of equilibrium in the case of a dirt pile? Of a road cut, or an abandoned field? What would correspond to a peneplain in the case of a dirt pile? Try to find a dirt pile that is approaching this point. Is equilibrium ever really reached in the case of a dirt pile? A road cut? A field? A mountain range? Why or why not? Is there such a thing as a landscape in a state of equilibrium.

Fruther Considerations:

Contrast man-made erosion with geological erosion. How are they the same or similar? How are they different? Man can destroy a field or area through the erosion which results from his activities. How long does this take, relative to the time required for geological erosion to occur? Such an eroded field or area is restored to something approximating its original condition through the natural processes of ecological succession. What is this process? How long does this take? Can man also take measures to restore the field or area? How? How long does this take relative to the time required for the natural process?

How is soil formed under natural conditions? Study the soil layers in a road cut or on the side of a freshly dug ditch. Identify the A-layer, B-layer and C-layer. You can find these if the surface has not been disturbed perviously. What are they? How are they related to one another? How are they related to the distribution of soil nutrients? How are they related to soil destruction through erosion, and to soil restoration?

What are "oxbows" and "oxbow lakes" in terms of the age and history of streams? How are they formed? In what kind of landscape would you look for them? Why? What are "canyons" in terms of the age and history of streams? How are they formed? In what kind of landscape would you look for them? Why?

How are mountains made? How long does it take? What constitutes the geological cycle of erosion?

Chemical Indicators: A Simple Case of Equilibrium

Introduction:

Chemists recognize two large classes of compounds called acids and bases. These are soluble in water, and a particular solution may be acidic or alkaline (basic). When an acid and a base are allowed to react chemically, the result is a compound belonging to a third class, called a salt and water. Common table salt is one kind of salt. It can be formed by allowing sodium hydroxide, (NaOH), a base, to react with hydrochloric acid (HCl):



There are many kinds of acids, bases, and salts. A common household acid is vinegar, and a common household base is ammonia.

Some pigments, when in water solution, are very sensitive to acids and bases, and react to them by changes of color. One of these is the purplish or bluish pigment found in "red" cabbage. It turns pink or red when an acid is added, and blue or green when a base is added.

Since the materials and equipment necessary for experimenting with this pigment are easily obtainable, you can learn something about acids and bases by working with it in the laboratory.

Materials and Equipment:

"Red" Cabbage

Household ammonia

Vinegar

A small, smooth board

A Gem razor blade

Four small fruit juice glasses

A shot glass, or other small clear glass container

A small tea strainer

A small pan, and a source of heat for heating water

A teaspoon measure

Two medicine droppers

Procedure:

1. Remove two or three leaves from the outside of a head of red cabbage. Select the thinnest portions of the leaves, and cut them up as finely as possible by placing them on a board and cutting them into little bits with a razor blade. If you can mash them or macerate them, this is better.
2. Place the cut-up material in one of the fruit juice glasses. Heat a small quantity of water to boiling, and carefully pour enough water over the cabbage material to cover it. The less water you use the better. Let the mixture stand for a few minutes, stirring it frequently. What happens? Allow all of the purple (or blue) pigment to go into solution in the water that will do so. (Note: The pigment can be extracted with cold water but more of it will go into solution if the water is hot.)
3. Pour the colored solution into a second fruit juice glass. Pour it through a small tea strainer to hold back the solid cabbage material.
4. Pour a small quantity of ammonia into a third fruit juice glass, and a small quantity of vinegar into a fourth glass.

5. Put two teaspoonfuls of the colored solution into a shot glass or other small clear glass container. With a medicine dropper add vinegar, drop by drop to the solution. What happens? Stir the solution as you add the acid. When there is no further color change, add ammonia, drop by drop, using the second medicine dropper. What happens? Why the second medicine dropper? Again, stir as you add, until there is no further color change.
6. Is it possible, now, to reverse the color change by adding acid? Try it and see. If you succeed in reversing it, add ammonia and try to change it back the other way. Does it change again? How many times can you change the color back and forth? If you come ultimately to a point where a reversal is no longer possible, why do you think this has occurred?
7. Now replicate the experiment, beginning with a new sample of colored cabbage pigment solution. Are the results the same as before?
8. Explain what you have observed in terms of equilibrium. What do you think was the original condition of the colored pigment solution? Neutral? Acid? Alkaline? Why?

Further Experimentation:

For this, you will need some additional equipment and materials:

- A test tube rack
- 9 small test tubes
- A tablespoon measure
- Litmus paper
- A third medicine dropper

Put a tablespoonful of water in each of nine test tubes in a test tube rack. Beginning at the left, add vinegar with a medicine dropper to the first four tubes as follows: (use the same dropper that you used with the vinegar before)

No. 1	20 drops	No. 3	10 drops
No. 2	15 drops	No. 4	5 drops

Do not add anything to the water in the test tube No. 5. Continuing, then, from left to right, add ammonia to the remaining four tubes as follows: (Use the same dropper that you used with the ammonia before)

No. 6	5 drops	No. 8	15 drops
No. 7	10 drops	No. 9	20 drops

Now you have a gradient of dilutions ranging from left to right from very acid, through neutral, to very alkaline.

Litmus paper contains a pigment which, like that in the red cabbage, changes color, becoming red with acid, blue with alkaline. Test your gradient of acidity and alkalinity with litmus paper. Note color changes. Are they reversible in the case of the paper?

Using a third medicine dropper, add a few drops of the cabbage pigment solution to each of the test tube dilutions. Note all color changes, both kind and degree. Do you obtain a gradient of colors? Why?

What would you say as to the relative sensitivity of litmus\your cabbage pigment solution? Are both equally sensitive? A number of pigments change color similarly with acidity and alkalinity. Such pigments are called indicators. What practical use do they have. What is meant by pH?

Measurement as an Expression of Relationship:
A Simple Balance

Introduction:

We are so accustomed to using units of measurement, inches, feet, yards, pounds, quarts, gallons, or millimeters, centimeters, meters, grams, kilograms and liters, that we tend to think of these units as things that have an existence of their own. They are a part of our thinking, just as words for physical objects are. We also tend to think of them as "tools," as a means to the end of quantitative expression. They certainly fulfil this function, but they are actually more than this. They are expressions of relationship between two quantities, one of which is stated in standardized terms. This is the idea of measurement which underlies the making and use of measurements.

Actually units of measurement are man-made, with an arbitrarily set value. A foot was the length of the foot of an English king. A yard was the length of the arm of another king. The British and American gallons are not the same. The height of horses was formerly measured in units called "hands". An old English unit of weight was called a "stone."

The metric system was worked out logically at the time of the French Revolution. The meter was set as one ten-millionth part of the distance from the equator to the north pole of the earth.* All other quantitative measurements were based on it, worked out in multiples of ten. The only reason that we use "tens," however, is that we have ten fingers. The Ancient Babylonians used "twelves," and the Mayas "twenties" (ten fingers and ten toes.) Modern electronic calculators use a numbering system based on "twos", since only two alternatives are possible in any particular case.

It is possible to set up a system of measurement of your own. To do so will help you to think of measurement as a standardized but artificially-based expression of a set of relationships. When you have done this you can translate your system into standard units.

Materials and Equipment:

Yardstick (new, clean, and as free of knots or grain as possible)
Triangular file
Frozen fruit juice cans, with tops removed
Soft wire
BB shot
Pennies
String
Set of gram weights
Support for suspension of balance

*Because of difficulties in getting an accurate measurement of this geographic distance, the metric system is now based by international agreement on the length of the waves of light produced by a particular type of atom of the gas krypton, when those atoms are heated.

Procedure:

1. Using the file, make a notch across the top of the yardstick at its exact midpoint. The notch should be deep enough to hold the string. Using a piece of string about six inches long, tie it around the stick with the knot lying in the notch, leaving the two ends of even length. Tie the ends of the string together, and hang the stick from the support. Does it balance, or is one end higher than the other?

2. With the file, make shallow notches across the top of the stick at each quarter-inch mark, from the midpoint to the end of each side. Be careful to make the notches straight across the top of the stick, as uniform in depth as possible, and each one exactly on the quarter-inch mark. Suspend the stick again. Is it as well balanced as before? If it isn't, what do you think has happened?

3. Punch a small hole on each side of two fruit juice cans, just beneath the rim at the top of the can. Cut two pieces of wire of equal length. Pass a piece of wire through the holes in each can. Tie the ends together in such a way that the can may be suspended from the stick, and moved along from one notch to another.

4. Suspend the cans from the last notch at each end of the stick. Do they balance? Reverse them. Do they work as well, regardless of the end from which they are suspended? Either the stick or the cans or both may not be completely balanced. Select one can for the right side and one for the left side, and mark them, so that you can use them this way from this point on. Add BBs to the can on the side that hangs highest, to bring it into balance. Write down the number of BBs used, and leave them in the can. They constitute the necessary correction factor at this point.

5. Add 50 BBs to each can. Are they still in balance? Is the correction factor still valid? If not, can you suggest a reason why? Test your hypothesis, if you can think of a way of doing so. In any case, adjust your correction factor, if necessary, by adding or subtracting one or more BBs, and proceed. Be sure to keep a record of what you have done.

6. Move both of the cans containing the BBs toward the center, one quarter-inch at a time. Bring them as close together as you are able without the cans touching. Are additional corrections necessary as you proceed? Add or subtract BBs as necessary, keeping a record of the number of BBs and the points where any changes are made. If adjustments are necessary, can you suggest a reason why? Test your hypothesis if you can devise a way of doing so.

7. Remove all BBs from the cans, and balance the cans at a point three inches (12 quarter inches) from the mid-point. Add BBs to serve as a correction factor to the extent necessary. Is the correction factor at this point, using the empty cans, what you would have predicted it to be? If not, can you suggest a reason why? Test your hypothesis if you can. In any case, proceed, using the necessary correction factor.

8. Place a penny in the left-hand can. Add BBs to the right-hand can to balance the penny. How many BBs does it require? Add a second penny on the left-hand side, and move the right-hand can out from the center one quarter-inch. Add BBs as necessary to achieve a balance. Record the data. Continue to add pennies one at a time, moving the right hand can out from the center one quarter-inch with the addition of each penny, and adding BBs each time as necessary to achieve a balance. Continue to record the data.

9. You are now weighing the pennies, using "quarter-inches" and "fractions of quarter-inches" as weight units. The fractions are expressed in terms of BBs. Thus a penny may weigh "one quarter-inch and two BBs." Is the weight of each additional penny the same, as you move from near the center toward the right end of the stick? If there are differences, are they consistent as you move along? Is there a trend? Determine the average. Try to account for what you find. Test your hypothesis if you can think of a way to do so. Try beginning farther from the center. Do the ages and relative wear of the pennies make any difference? Think of other ideas to test.

10. Now determine the value of a "quarter-inch" in terms of BBs. Start with empty cans at the twelfth notch (three inches) from the center on each side. Balance the cans again, using whatever correction factor is necessary. Put 50 BBs in each can to start. Move the right-hand can out one quarter-inch at a time, and add BBs to the left-hand can as necessary to maintain a balance. Record the number of BBs added to balance each additional quarter-inch the right-hand can is moved. Is the number the same each time? Is there a trend? Determine the average. Are your results consistent with those that you obtained with the pennies? If not, suggest a possible explanation. Test your hypothesis if you can devise a way of doing so. It might be a good idea at this point to replicate the entire experience, using new materials throughout, to see if the results are the same or comparable.

Further Considerations:

Both equal arm and unequal arm balances can be used to weigh quantities. Ordinary laboratory balances are equal arm balances. Unequal arm balances were formerly in use on farms and elsewhere for weighing sacks of grain, and other quantities. They were called "steelyards."

What would you say as to the margin of error in your balance. Work out the equivalence of the quarter-inch unit on your balance in grams. Number the notches on each end of the stick. Start with the first notch at each side of the center notch as "1", and number toward each end. Weigh various objects with your balance. Check the accuracy of the figures obtained by weighing the same objects on a laboratory balance. Explain the operation of your balance in terms of a lever.

How does a spring type scale work? Which do you think would be more likely to develop inaccuracies, a spring type scale or a balance type? Why?

What are the relationships between weight, mass and density? What is meant by specific gravity? What standard is used for expressing it? How is it possible to calculate the weight of the earth? On what basis is the statement made that the moon has a lower density than the earth? What determines the force of gravity? Why would a man weigh less on the moon's surface than on the earth? What about Mars?

A Study of Interrelationships: The Balanced Aquarium and the Pond Infusion Culture

Introduction:

The ideal way to study plant-animal communities is to go on a field trip to see them. It is not always possible, however, to do this. Time, distance and facilities may not permit it. The following set of experiences may therefore be used as a substitute. They may also be used to supplement a field trip to a pond or lake.

A balanced aquarium is a miniature pond in the laboratory. The succession of forms of microscopic life in a pond infusion culture leads ultimately to a small balanced community which is comparable to a balanced aquarium. A study of a balanced aquarium and a pond infusion succession will help to develop an understanding of the interrelationships involved in the larger communities of living nature: ponds, lakes and forests, and the processes of succession through which these pass in developing a relatively stable (dynamically balanced) condition.

In setting up these experiences, you can proceed on your own, but you must be careful. Slipshod procedures, or failure to follow directions may result in failure of the aquarium to come to balance, or failure of the infusion culture to go through a normal succession. Exact results in any case are impossible to predict. The development of the culture, however, should follow a predictable general pattern. Failure of the culture to do so, or variations from the pattern, will furnish interesting opportunities to suggest hypotheses as to possible causes, and may constitute the basis for further experimentation.

Balanced aquaria may be set up on an individual basis. Infusion cultures lend themselves to group activity, but at least six different cultures should be set up by teams of students in the class in order to make possible a study of variations in their behavior.

Materials and Equipment:

- Gallon and quart size glass jars
- Compound microscopes
- Medicine droppers
- Slides and cover slips
- References for identification of aquatic organisms

Procedure:

Constructing a Balanced Aquarium

Obtain a jar or other clean glass container of at least one-gallon capacity, which has an opening large enough that you can get your hand into it.

Get some river or lake shore sand as free of dirt and debris as possible. Wash it thoroughly through several changes of water. Place sand in the bottom of the container to a depth of two inches. Fill the container with water to a level such that when you put your hand to the bottom the water will not overflow. Allow the sand to settle until the water becomes reasonably clear.

Put a number of aquatic plants into the aquarium. Collect them from a pond or a quiet pool in a stream or purchase them at an aquarium or pet store. You may use more than one kind of plant, some floating (duckweed), some rooted in the sand with the main plant body submerged in water (eel grass or elodea), and some rooted but having floating leaves. Why would it be unwise to get plants from an actively flowing stream? What advantage might there be in obtaining your plants from an aquarium store? Why? Watch size relations. Do not put large plants into a small container.

Put a few aquatic animals into the aquarium. Why "a few"? Snails are the best animals for this size container. Larger animals would be difficult to support in so small an aquarium. Why? Most snails are herbivores (plant eaters) and are more likely to find an adequate food supply here. Do not include tadpoles, because these, as adult frogs, live outside of water. Do not include aquatic insects or fish. Many of them are carnivores (animal eaters) and probably would not have enough food and oxygen for very long. To support carnivores, a balanced aquarium would have to be much larger and contain many more plants and small herbivores. How much larger do you think it would have to be? Why? If you have been successful in building your aquarium, it will become balanced at the "snail level".

Cover the jar with its own lid or glass cover, or with Saran wrap, to minimize water loss through evaporation. Allow your aquarium to stand for at least two weeks. If, at the end of two weeks, the water is clear, if it smells "fresh," and if the plants appear healthy and the animals are alive, the aquarium is approximating a balance. The longer it continues in this condition, the more probable is the balance.

Your balanced aquarium will maintain itself successfully in any window during the winter months. An east or north window is best for a year-round location because the aquarium is more stable in a place where it receives plenty of strong indirect light, and only a small amount of direct sunlight. In summer, west and south windows are too hot for an aquarium.

Although daily and seasonal light and temperature changes in the classroom are not as extreme as they are out-of-doors, such changes do occur. You can watch the changes that take place in your aquarium as the seasons change.

List the different kinds of plants and animals that have become established in your aquarium. What is the relationship of each life form to the aquatic community of which it is a part? What are the sources of oxygen, carbon dioxide and mineral salts for food-making

and respiration? What about the activity of colorless plants? What evidence do you see for their activity?

The final result of your balanced aquarium experience is an aquatic micro-community which should remain relatively unchanged over a long period of time, if the conditions of its environment are not changed. The only way available for use to judge the achievement of this balance is by observing its continued success. Chemical analysis might be possible, but not at the level at which we are operating. Nevertheless, the judgment of a biological result on the basis of a kind of biological test or essay is a method widely used. What other examples of it can you think of?

Setting Up A Pond Infusion Culture

Fill a quart jar about 3/4 full with plant material from the edge of a pond, including some of the floating and submerged green vegetation and some of the dead vegetation from the pond bottom. Be careful not to include mud. Fill the jar to a point near the top with water taken from the area where it has been stirred up. In doing this you will have secured a representative sample of the microscopic aquatic organisms in this environment.

A sample secured in this way will contain a maximum variety of microscopic forms. Not all of them will appear, however, on immediate microscopic examination. Therefore, the jar should be allowed to stand for twenty-four hours. By this time the organisms will have oriented themselves to the changed situation, and a more accurate survey can be made.

A pond infusion culture consists simply of a jar of material obtained in this way, and allowed to undergo the natural changes which occur over a period of days or weeks as a result of the changed environmental conditions to which it is exposed in the laboratory.

When kept in the laboratory, the culture should be placed in a window, but not allowed to stand in direct sunlight. It should be moved as little as possible. The same side of the jar should be kept exposed to the light from the window. Why should the culture be maintained in this way? In what ways does the laboratory environment differ from the pond environment? What physical factors of the environment are changed when the material is brought into the laboratory, and to what extent? What biological factors are changed, and to what extent? Predict possible effects that these changes may have on the living organisms brought in from the pond, and then try to determine the validity of your predictions during the period of your observation of the developing culture.

Succession in the Culture Jar Community

In securing samples from the culture jar for study under the microscope, fill a medicine dropper as you scrape the end of it up and down through the top film of the water against the glass on the

side of the jar nearest the window. By this means you should secure a sample of the organisms in approximately the top one-fourth inch of the water. What environmental factors are you taking into consideration when you take a sample in this way? How do these operate in the plant-animal community?

In addition to any other considerations involved in taking samples in this way, there is the advantage afforded by uniformity. Samples which are taken in the same way each time the culture is studied make possible a comparison of results. Additional samples may be taken from other parts of the culture, using different methods of sampling, but these also should be uniformly obtained. Such samples may be compared with the ones taken as indicated above. In every case at least three samples should be studied from any locality in any particular jar on each occasion. Why?

In identifying the organisms observed, the following standard and easily obtainable reference books are helpful:

1. Eddy, Samuel, and Hodson, A. C., Taxonomic Keys to the Common Animal of the North Central States. Burgess Publishing Company, Minneapolis, Minnesota, 1955.
2. Needham, James G. and Needham, Paul R., A Guide to the Study of Freshwater Biology. Holden-Day, Inc., San Francisco, California, 1962.
3. Jahn, T. L., How to Know the Protozoa. William C. Brown and Company, Dubuque, Iowa, 1949.
4. Ward, H. B., and Whipple, G. C., Freshwater Biology. John Wiley and Sons, New York, 1918. (Second Edition, W. T. Edmondson, editor, 1959.)

Since common plankton forms are generally world-wide in their distribution, any good reference book on microscopic aquatic organisms will be useful. Any reference book used, however, should contain pictures or sketches of the common organisms for ready identification. Keys are necessary for detailed identification, but for the type of recognition involved here, time is not available for such identification, nor is it necessary. It is better to leave an occasional animal unidentified than to "lose sight of the forest in studying the trees". The goal of the experience is to understand the interrelationships which exist in the community, not to identify a large number of organisms.

Ask your teacher to verify the identification of the organisms that you have seen. Your teacher may then draw rough sketches of these organisms on the blackboard, emphasizing such readily observable characteristics as body shape, size, and outstanding features of appearance. Sketches of this type will enable others to recognize the organisms if they see them. It is well if these sketches can remain on the board during the progress of the study, being supplemented with additional ones as new organisms are discovered. Usually all of

the more common organisms in the culture are identified during the first few periods of observation. Remember that all organisms which appear at any time during the development of the culture must necessarily be derived from those which were present at the beginning. Nothing new is introduced.

If you wish to do so, you may avoid all identification of genera and species of the microscopic animals and plants by simply placing the organisms that you observe in a few major groups: (1) flagellate protozoa (2) ciliated protozoa, (3) rhizopod protozoa, (4) microcrustacea, (5) miscellaneous arthropods, (6) worms, (7) single-celled and colonial green algae, (8) filamentous green algae (9) diatoms (10) blue-green algae, and (11) bacteria. This procedure has certain advantages from the standpoint of summarizing results, and it is very easy to carry out.

The culture may well be examined daily during the first week or even two weeks. If it is desirable to carry on other class activities during this time, however, examination on alternate days will be sufficient. The changes during the first two weeks are rapid and interesting. After the first two weeks, examination once a week or even less often will be enough to detect the slow changes which are occurring. After six weeks, a single examination at the close of the semester or the school year will serve for comparison with the balanced aquarium. If old culture jars are available, containing mature cultures from previous years, these also may be studied and used for purposes of comparison.

Work out a means of quantifying your data. This may be done by combining the results of the entire class at the close of each period. Use the sketches on the board in helping to determine class totals. Exact counts are not necessary. It is usually sufficient to state results in terms of rough categories such as, "very abundant", "abundant", "many", "few", and "rare". Quantification of this kind serves as a useful summary of the work of each period, and helps to present to the class a picture of the changing scene of the culture as the succession progresses.

In general, the predominant organisms in the culture during the first few days are those which are common in plankton samples taken directly from the pond: microcrustacea, green algae, diatoms, blue-green algae, aquatic annelids, insect larvae, other micrometazoa, and protozoa in small numbers. After a few days, the green forms, the microscopic metazoa and some of the kinds of protozoa become fewer in number and disappear. Processes of decay set in, bacteria multiply and are seen in large masses, and the ciliate protozoa (paramecium and others) that feed on bacteria become abundant. This stage may last for several weeks. Then, as decay runs its course, the bacteria and bacteria-feeders diminish; the green and blue-green algae become abundant again; such microscopic metazoa as have lived through the period of decay are again seen in small numbers; and the culture slowly attains a balance. Ultimately it becomes a miniature balanced aquarium, balanced at the microscopic level.

At this point, a comparison with the gallon jar balanced aquarium which was constructed at the beginning of the study should be made. How are they similar? How do they differ? Why? Why was it possible to construct the larger balanced aquarium without its having to pass through the succession stages which took place in the case of the culture jar? How are both of the balanced aquaria similar to the plant-animal community of a pond, lake or the ocean? How are they different?

Further Investigations:

What are the implications of the pond infusion culture-balanced aquarium study for understanding some of the methods of purification of city water supplies? For some of the methods of treatment of sewage? Visit a city water plant and a city sewage disposal plant if possible, and see these processes in operation.

What are the implications of the study for a possible part-solution of the problem of a food supply for the world's future dense population in the form of "farming" the rivers, lakes and oceans for food? What are the implications for maintaining a food supply in a space ship traveling vast distances over long periods of time? What kinds of research are now being done on both of these problems?

What kinds of controlled or semi-controlled experiments could be set up to study further the problems raised by the pond infusion culture? Set some of these up and try them.

Theories of the Origin of the Universe: Two Approaches to Dynamic Equilibrium

Introduction:

Scientists make certain basic assumptions in connection with their work and thinking. These assumptions serve to define the way they look at the natural world, how they behave toward it, and how they expect it to behave.

One of these basic assumptions is that of uniformity or uniformitarianism. Scientists assume that the natural world is the result of forces and processes which operated in the past, are operating at present, and will continue to operate in the predictable future. This holds true in the making of an erosion pattern of hills and valleys, the growth and decay of a forest, the appearance and extinction of a species, or the birth and death of a star. Scientists think that no event is unique; anything which has occurred can occur again given the same set of circumstances. All natural laws assume consistency and repeatability as opposed to catastrophes that happen only once.

Another of the basic assumptions of science is that of continuous discovery. Scientists hope to go on learning more and more about the natural world until eventually all may be understood. They recognize that it may never be possible to realize the goal of complete knowledge, but their way of looking at the world demands that they continue trying to do so. If they do less than this, if they permit any authority to say, "You must not investigate this problem," or "You must not ask this question," they violate the meaning of science. Scientists seek for objective truth, and they must ask all possible questions when these questions concern the natural world.

Two of the problems which scientists have to face about the natural world are those concerning the physico-chemical origin of life and the origin of the physical universe.

Theories of the Origin of the Universe:

Until the middle 1920's theories of origin were concerned largely with the origin of the solar system, the sun and its family of planets. Scientists did not know enough about the universe as a whole to be aware of its nature and extent or to attempt to determine its origin.

In the middle 1920's, however, Edwin P. Hubble discovered that our star group or galaxy, in which our sun is only one of possibly 100 billion stars, is one of millions of more or less similar galaxies scattered throughout known space. Furthermore, he discovered that all of these galaxies are moving away from one another at constantly increasing velocities; the farther away they are, the greater the velocity. Read about the use of the spectroscope to determine this movement of the galaxies. What is the Doppler shift? Presumably the velocity continues to increase with increasing distance until it reaches the velocity of light, 186,000 miles a second. According to Einstein's Theory of

Relativity, this is the greatest velocity which it is possible to attain. Certainly we could not see the light from a galaxy traveling away from us at this velocity, since the velocity of the light coming from it toward us would be exactly canceled out by the velocity of the source of the light moving away from us.

Hubble's discovery made it necessary for scientists to widen their problem from the nature and origin of the solar system to the origin of the universe as a whole. On the basis of what we know at the present time, there are basically two possible explanations, but we do not yet have sufficient evidence to enable us to accept either of them to the exclusion of the other.

1. If the theory of universal expansion means only that the galaxies are getting farther apart, it should be possible to project the process backward to a point in time at which our present universe began with a kind of explosion of a relatively small, extremely dense mass. Presumably, this contained all of the matter which now makes up all of the galaxies, stars and other bodies in the universe.

This explanation implies a kind of "beginning", and also some kind of "end". At least we can look forward to a situation in which the velocities of receding galaxies all attain the speed of light, and therefore the light which they radiate is no longer visible to an observer located in any one of them.

2. On the other hand, if universal expansion is only a property of space itself which carries the galaxies along with it, space has no real "center." The expansion appears to be taking place in all directions from any point in space where the observer may be located. This is comparable to the fact that, when you are inflating a toy balloon, all points on its surface are moving away from any particular designated point. (Why don't you try this out?)

Since matter in the form of galaxies may be assumed to be constantly "disappearing" as the galaxies attain the speed of light and "wink out" in the ultimate distance, it may also be assumed that new matter is constantly "appearing" somewhere in space while it is expanding. Since hydrogen is the simplest chemical element, and therefore the most basic form of matter, it is assumed that this is the form in which new matter appears. Hydrogen is the most abundant element in the universe (slightly over 50 per cent). It would appear that the new hydrogen might be synthesized into more complex chemical elements, then into cosmic dust and ultimately into new stars and galaxies which would "flow outward" with increasing velocity toward ultimate extinction.

This explanation implies that the universe we see constitutes a kind of continually "flowing fountain" of galaxies and stars.

Each of these possible explanations has come to form the basis of one or more theories of the origin of the universe. Fortunately for readers who are not astronomers, both points of view have been championed by scientists who are able to write in easily readable, non-technical style, and their writings have been published in popular paperback books.

The first explanation has given rise to what has sometimes been called the "Big Bang" Theory, or as a more dignified title, the Evolutionary Theory. (This should not be confused with the Theory of Organic Evolution in the living world.) The Evolutionary Theory of the origin of the universe has been set forth particularly by Dr. George Gamow of George Washington University.

The second possibility has given rise to the Continucus Creation or Steady State Theory of origin. Its principal proponent for the general reader has been Professor Fred Hoyle of Cambridge University. Both men have done an excellent job of explaining their points of view, and giving evidence to support what they believe.

A variant or extension has been proposed for the Evolutionary Theory. It constitutes an attempt to face the twin problems of "What was there before the 'big bang?'" and "What will be the ultimate fate of the universe?" The basic scientific assumption of uniformity which was set forth above in the Introduction makes it necessary to face these questions. What is this so?

This variant is called the Oscillating Universe Theory. This theory has been championed by Dr. Ernst J. Opik of Armagh, Northern Ireland. It assumes a periodic expansion and contraction of the universe, like the alternate stretching and releasing of a rubber band. Expansion continues to an ultimate point, and then a corresponding contraction sets in. This continues until a point of ultimate density is reached, and a new expansion takes place with the formation of another set of galaxies containing new stars, and possibly planets like our own. How does this satisfy the demands of uniformitarianism?

Equipment and Materials:

Popular paperback books dealing with the nature and origin of the universe

An open mind with some imagination, and a desire to understand

Procedure:

1. Read "Introduction," pp. XI-XIII, and "Conclusion," pp. 134-136, in The Creation of the Universe, by George Gamow, A Mentor Book, the New American Library* MD214, 1952.
2. Read Chapter 6, "The Expanding Universe," pp. 93-115, in The Nature of the Universe, by Fred Hoyle, A Signet Science Library Book, the New American Library P2331, 1960.

*The New American Library of World Literature, Inc., 501 Madison Avenue, New York 22, New York.

3. Read Chapter 1, "The Universe, Geometry, and Relativity," pp. 11-46, Chapter 2, "The Expansion of the Universe," pp. 47-79, Chapter 6, "The Evolutionary Theory," pp. 131-160, Chapter 7, "The Theory of Continuous Creation," pp. 161-180, and Chapter 8, "Discussion of the Theories," pp. 181-206, in Modern Theories of the Universe, by James A. Coleman, A Signet Science Library Book, the New American Library P2270, 1963.
4. Read "The Expanding Universe: Its Origin and Fate," pp. 114-124, in The Oscillating Universe, by Ernst J. Opik, A Mentor Book, the New American Library ND289, 1960.
5. Read in all four books any additional material which you find helpful and interesting. Try to understand it as best you can. (Everyone finds some of this material difficult to understand, so do not be discouraged.)
6. Consult any additional references that you wish. The following paperbacks are suggested for additional reading:
 - a. Frontiers of Astronomy, by Fred Hoyle, A Signet Science Library Book, the New American Library T2309, 1955.
 - b. The Birth and Death of the Sun, by George Gamow, A Mentor Book, the New American Library MD120, 1952.
 - c. The Unity of the Universe, by D. W. Sciama, A Doubleday Anchor Book, Doubleday and Company, Inc., A247, Garden City, New York, 1961.
7. Check the backfiles of Time and other news magazines (in the Science Section) for pertinent articles on the theories of the origin of the universe.

How does the fact of the expanding universe (Hubble's discovery) present a problem from the standpoint of equilibrium in the universe? Why is it necessary for us to think of the universe as being ultimately in a state of equilibrium? How does each of the theories attempt to deal with the problem in such a way as to present a picture of equilibrium? Does each of the theories do an equally good job of presenting a picture of equilibrium in the universe? Why or why not?

How does each of the theories measure up in terms of the basic scientific assumption of uniformity? Do they measure up equally well? Why or why not? How is uniformity related to the idea of equilibrium?

Further Considerations:

What is entropy? Why has it been called "the running down of the universe?" How does it appear to be related to the continuous expansion of the universe? How does it appear to be related to the one-way flow of time? How does the one-way flow of time appear to be related to the expansion of the universe? What would appear to happen to time in the case of a pulsating universe? What would appear to happen to entropy? Would this seem to present a barrier to acceptance of the pulsating theory?

Science fiction stories are written about time travel as well as space travel. What do you think about the possibility of time travel as compared to that of space travel? Why?

Under the Theory of Relativity, matter and energy are basically equivalent. Matter can be changed into energy, and energy into matter. The energy released in the explosion of a nuclear bomb (A-bomb or H-bomb) comes from the conversion of a very small amount of matter into energy. Conversely, in a cyclotron, a very small amount of matter is "created" by converting energy into matter. How is this related to the ideas involved in each of the theories of the origin of the universe which have been presented? Is it related to both, or to only one? If only one, which one? Why?

Also under the Theory of Relativity, as the velocity of an object approaches the velocity of light, its mass approaches infinity, and time for it approaches zero. Also the object which is moving becomes flattened in the direction of travel. As the velocity of light is approached, this dimension of the object also approaches zero. No one, not even the mathematicians who arrived at this theory, can imagine this condition of infinite mass, zero time, and two-dimensional volume. No object has ever been observed to travel this fast. Assuming, however, that they are correct, how are they related to the ideas involved in each of the theories? Are they related to both, or to only one? If only one, which one? Why?

All life on earth is dependent on energy from the sun which is fixed into organic material (carbohydrates, proteins and fats) by the process of photosynthesis. After passing through a series of organisms, the stored energy is dissipated into the environment. (Green plants are eaten by herbivorous animals, which are eaten by carnivorous animals, and finally, all waste materials and dead bodies are broken down by the action of colorless plants which act as decomposers.) If it were not for the continual input of fresh energy from solar radiation, all life on earth would cease. Energy use is a one-way street. This ultimate dissipation of energy is true also of the energy which we use in carrying on various physical processes. How is this related to entropy?

In terms of the theories of origin which have been presented, is this "one-way" aspect true of the entire matter-energy picture in the universe? Or is there an ultimate equilibrium if the picture is considered in sufficiently broad terms? Is the answer to the above question equally applicable to each of the theories or only to one? If only one, which one? Why?

IV

Idea of Change and Variation

1. **Idea-Bridge: "Thinking About Change and Variation"**
2. **Laboratory Experiences:**
 - a. "Looking for Examples of Patternless Change"
 - b. "Normal Curves and Warping Factors"
 - c. "Relationships Among Different Kinds of Change: Daily, Monthly, and Annual Temperatures"
 - d. "The Emergence of Patterns"
 - e. "Decomposition of Materials"

Thinking About Change and Variation

It has been said that nothing is changeless but change. Certainly we live in a dynamic rather than a static world and universe. Perhaps we have become so accustomed to change that we do not notice it. Nevertheless, if we think about, even a little, we see that there appear to be at least two kinds of change: patternless and patterned.

We watch cumulus clouds on a summer day. If we pay close attention to them, we see that they are never the same for any two successive moments. Furthermore, we cannot predict the details of their appearance at any particular moment from knowing how they looked the previous moment. Their movement appears patternless. This is true, however, only of the details of their movement. When regarded in large, over an entire day or even an hour, their movements can be seen as a pattern. This pattern can be related to other patterns: of wind movement, and of temperature, atmospheric pressure, and moisture content.

Let us consider another example. Looked at in terms of individual days at any season of the year, temperatures taken at a specific time each day appear patternless. Looked at in a larger sense, day-to-day changes do form patterns. Any number of additional examples could be cited. It seems possible, then, that our two kinds of change, patternless and patterned, are related. If we look at details, change may appear patternless, but if we consider a larger perspective, patterns become apparent.

Variation in nature is related to change. It is a form of change in which the results persist. Patterning factors operate upon a field of variation to transform a basically patternless expression into observable patterns. The world is a world of variation, but the variations generally are found to be patterned when we study them.

It is the job of science to discover and describe patterns in nature and predict their operation. Natural laws are descriptions of patterns which operate consistently. There are many kinds of patterns in nature because there are many kinds of factors that operate to produce patterns. Scientists try not only to discover and describe the patterns which exist, but also to determine the factors which produce them and how they operate.

Looking for Examples of Patterless Change

Introduction:

What would the world be like if no one could predict what was going to happen next? To what extent are we able to predict what is going to happen? Why? On what basis do we do it? What kind of situations do we find in which we cannot predict? Why?

In this laboratory experience you will have an opportunity to observe an example of change which does not appear to "make sense." What do we mean by "making sense"? See if you can make sense out of what you see.

Materials and Equipment:

Compound microscope

Slides

Cover slips

Pipette

Cake of yeast (Red Star or Fleischman's)

Chalk dust

Procedure:

1. Place a piece of yeast no larger than the head of a pin in a drop of water on a glass slide. Tease it out so that the yeast becomes finely subdivided in the water. Place a cover slip on top of the drop.
2. Examine the preparation under the highest power of the microscope. Note the yeast cells. You will see that they are of different sizes. Are yeast cells capable of independent movement? Look at them closely. Do any of them exhibit any kind of motion? Describe the motion. Is the amount of motion related to the sizes of the cells?
3. Place a drop of water on a second slide. Put some chalk dust in the water. Cover with a cover slip.
4. Examine under the highest power of the microscope. Look for movement among the particles of chalk dust. Do you see any motion? Is it related to the sizes of the particles?
5. Try to explain what you have seen in both the yeast and the chalk. Is the movement which you have seen related to life? Why or why not? What causes it?
6. This is called Brownian movement. How would you describe it? What causes it? Observe it again, closely, both in the yeast cells and in the chalk dust particles. Look at a single moving cell or particle. Can you predict the direction of any of its movements by knowing its previous movements? Do its movements constitute patterned or patternless change? Is the change directional; is it "getting anywhere"? Is it cyclic? If the various movements were measured and placed on a graph, would they form a normal curve?

7. Look up the story of Robert Brown, the 18th century scientist who first observed this movement. How did he study it? What is the Kinetic-Molecular Theory? Was it known in Brown's time?

Further Considerations:

Study other examples of change and variation as you have studied the movement of minute particles. What about the movement of the wisps of vapor that make up cumulus clouds in the summer sky? Watch a cloud closely. Is the movement of the vapor patternless or patterned? What about the points of impact of raindrops on a flat surface? Is the distribution patternless or patterned? Can you think of any other examples of this kind in nature? Is the kind of change or variation which we have examined in this experience ever related to patterned change or variation? How do you think it might be related? How can you explain the evaporation of water in terms of the movement of molecules?

Normal Curves and Warping Factors

Introduction:

This laboratory experience bears somewhat the same kind of relationship to the process of scientific investigation and the generalizations that result from it (hypotheses, conclusions, natural laws) that bridge-playing bears to real-life competition in business or politics, and that chess-playing bears to military tactics and war. What is this relationship?

Materials and Equipment:

Pennies

Masking tape

Graph paper

Procedure:

Toss a single penny not less than 100 times. Record the number of times it falls heads and tails. Are the numbers equal? If so, why? If not, why? Formulate a hypothesis to explain your results. Devise an experiment or set of experiments to test your hypothesis. Compare your results with this penny to the results of similar experiments with other pennies. Are the results the same? If so, why? If not, why? Formulate a hypothesis. Test as before. Does the age of the penny have anything to do with it? If so, why? If not, why? Try tossing a nickel. Does the kind of coin you use affect the result? What else might affect the result? Investigate some of these possibilities.

Continue your hypothesis-forming and testing as long as you find it interesting, or as long as time will allow. Do not worry if you do not come to any definite conclusions, or if the conclusions you arrive at on the basis of your own experience differ from those of others. The conclusions that you reach are less important than the procedure by which you reach them. You are actually not carrying your experiments far enough in any case to justify drawing well-established conclusions. Why?

What does a scientist mean by sampling? How is this related to what you have been doing? How well can you predict a final result after 20 tosses? 50 tosses? 100 tosses? 1,000 tosses? How large a population of boys or girls would you need to consider in order to make a well-founded generalization concerning them?

What is a hypothesis? What is a natural law? What is inductive thinking? Deductive thinking? Where have you used each type of thinking? What is an experiment? How is it related to an observation? To what extent is science experimental? To what extent observational? What is a controlled experiment? How does it differ from an uncontrolled experiment? From an observation?

Now take an even number of pennies (6-10), and toss them together, counting the total number of tails that show each time. Do this as many times as possible, up to 100. Record your results for each toss in such a way that the data for your total number of tosses forms a curve:

	x
	xxx
Number	xxxxx
of Tails:	xxxxxxx
	<hr/>
	0123456

Transfer your results to a piece of graph paper. How closely have your results approximated a normal curve? Why? Any deviation from a normal curve is called a skewed curve, and is due to the operation of a warping factor. What are warping factors? Is a warping factor at work here? If so, what do you think it might be?

Calculate the total number of single-penny tosses involved in your result. Did heads or tails predominate in your mass result? Does this outcome support or contradict the conclusions you reached in working with single pennies? In case the two conclusions do not agree, which do you think would be the more valid? Why?

Put a thickness of masking tape on the head side of a penny. Be careful that the tape does not extend onto the edge of the penny. You have now introduced a possible additional warping factor into your penny tossing. Why did you need to be careful not to get tape on the edge of the penny?

Toss the penny at least 100 times as you did before. Record the number of times it falls heads and tails. Have you succeeded in warping the heads-tails ratio by attaching the tape to the head side? If so, to what extent? Now try adding a second layer of tape. Repeat the tosses. Is the ratio changed? Add a third thickness and try it again. Add a fourth and repeat. Is there any evidence of a progressively increased degree of warping? If so, is the change consistent?

Put a predetermined amount of tape on each of six pennies and toss them together as you did with untaped pennies, counting the total number of tails that show each time. Do this as many times as possible, up to 100. Record your data in such a way that your results form a curve. Transfer your results to a piece of graph paper. Does the warping factor which you have introduced show up in the form of a warped or skewed curve? Compare this curve with the one obtained from tossing six untaped pennies. Is there a difference?

Can you arrive at any sort of generalization concerning your results in tossing single pennies and six pennies without tape and with tape?

Further Considerations:

When examples of variation with regard to a particular characteristic in a sample population are quantified, and their frequency is recorded on a graph, the result may be a normal curve. In such cases we say that,

with regard to the characteristic being studied, the individuals making up the population vary around a norm. How does this differ from a patternless distribution? What factor or factors produce the pattern? Are these warping factors operating upon a patternless distribution?

What kinds of phenomena in biological and physical nature are describable in terms of a normal curve type of distribution? Can you think of some of these that you might survey, or investigate in the laboratory? What about height and weight in adult men and women? In boys and girls of the same age? Any others?

See if you can think of warping factors at work in biological or physical nature. Can you survey the operation of some of these, or try them out in the laboratory? What about degree of cloudiness in relation to temperature in a particular month? What about sex in relation to variations in height of men and women? Any others?

What is the relationship of normal curves and warped curves to the general phenomenon of patterns existing in nature? What kinds of patterns are there other than these two? What kinds of factors cause patterns? What is the relationship of patterns in nature to hypotheses? To natural laws?

Relationships Among Different Kinds of Change: Daily, Monthly, and Annual Temperatures

Introduction:

Some examples of change appear to be patternless, with the individual elements of change showing no apparent relationship to one another. Other examples appear to be progressive, moving in a specific direction. Still others show cyclic patterns, repeating themselves over and over again, after longer or shorter periods. Is there any relationship between directional and cyclic change? How are these patterned forms of change related to apparently patternless change? In this laboratory experience you will have an opportunity to study one example of the relationship of these different kinds of change to one another.

You are familiar with the fact that the month of January is colder than the month of April, and that the temperature taken at the same time each day in either January or April varies in relation to that of the days preceding and following it. You are also familiar with the fact of seasonal change: the progress of cooling, then warming of the seasons from fall, through winter, into spring, and finally summer. These phenomena can be measured, and the recording of the data show an interesting relationship between apparently patternless, directional, and cyclic change.

Materials and Equipment:

Thermometer (either Fahrenheit or Centigrade)

Graph paper

Ruler

Procedure:

1. Every day, from the first of October to the first of May, at the same time each day, read the outdoor temperature in a place not exposed to direct sunlight. Record the temperatures of the days of each month on a graph:

Degrees of
temperature

Days of the month
Name of Month

See if you can detect any relationship between the temperatures on successive days. What kind of relationship (if any) do you find? Is this relationship such that you could predict the temperature on any day by knowing the temperatures of the immediately preceding days? How accurately could you interpolate the temperature of a day if you

knew the temperatures of the day preceding and the day following? How much daily temperature change occurs? to what extent do daily temperatures furnish an example of patternless change?

2. Now for each month, plot the accumulated daily temperatures on a graph in the form of a frequency curve showing the number of days during the month when you recorded each particular temperature:

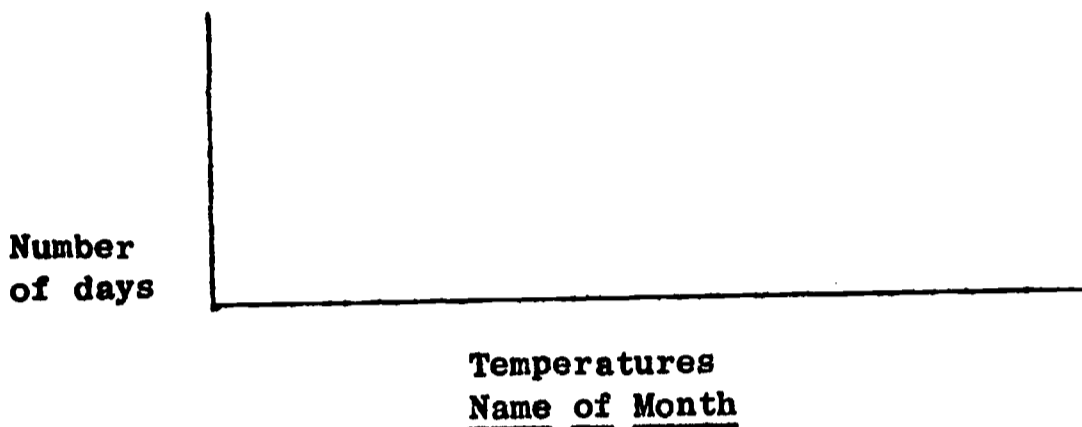

Is there a "piling up" or mode at any particular temperature? What was the most common daily temperature during the month? What was the range of variation? How closely do your results approximate a normal curve? Plot the daily temperatures with intervals of one degree, two degrees, three degrees, five degrees. By which method do you get the nearest approximation to a normal curve? Why?

Have you arrived at a pattern with relation to the daily temperature changes that occurred during the month? To what extent can apparently patternless variations of any kind be expressed in the form of a normal curve or a warped curve? Why? What causes the difference between normal curves and warped curves? What are warping factors?

3. Calculate the average (mean) temperature for each month. What is the relationship of the mean to the mode, the most frequently recorded temperature? Why?

Now make a graph of the successive mean temperatures of all the months from October till May:

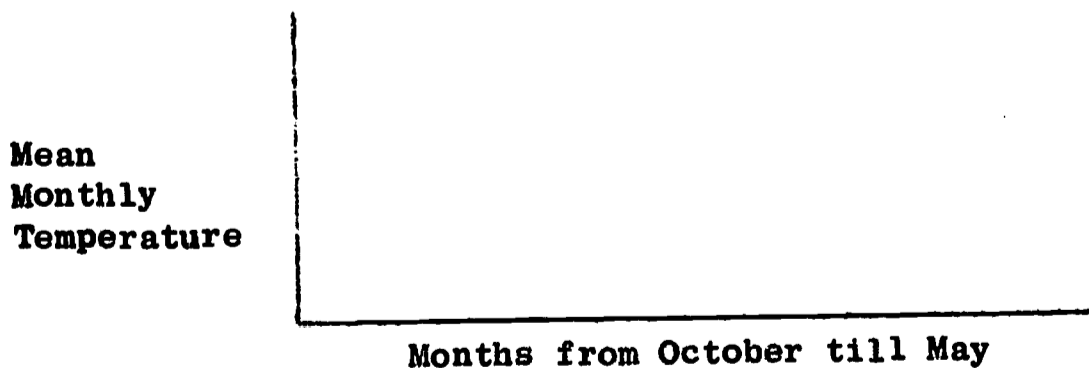

Is the result a gradient? Why? Compare the gradient for fall with the gradient for spring. Do you see a pattern of directional change? Could you interpolate the mean temperature for a particular month if it were missing? Compare this with the situation which you found in the case of the successive days of a particular month. Why do you think there is a difference?

Would you be justified in saying that the apparent lack of pattern among successive day-to-day temperatures within a particular month was due to the short period of observation, and that this daily patternlessness gives way to a directional pattern when there is a longer period of observation?

What do you think would happen if you were to show on a graph the successive mean temperatures of all of the months of a year? What would be the relationship of the seasonal gradients to one another? What is cyclic change? Is this a further kind of patterned change? How is directional change related to cyclic change in this case? Does this relationship also have something to do with the length of the period of observation? Why?

4. If you studied all twelve months of a year, you could, by averaging, obtain a mean temperature for the whole year. Then, if you studied a series of years, you could represent on a graph a series of such mean annual temperatures:

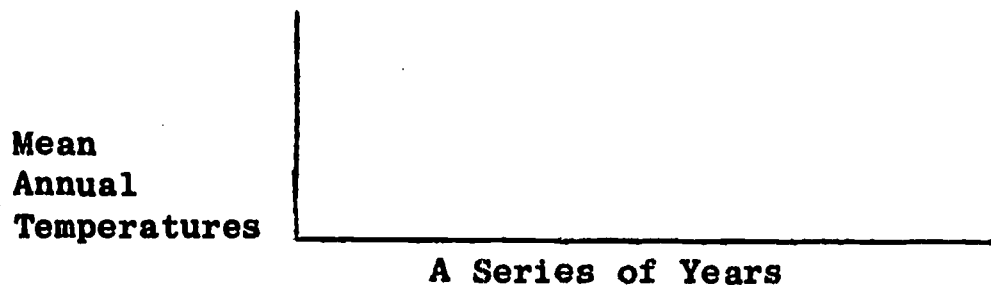

What kind of year-to-year change would you expect? Would it appear patternless? Would it appear directional? Would it appear cyclic? What are climatic cycles? To what extent do we have evidence for their existence? What does the length of our period of observation have to do with our knowledge of climatic cycles?

Further Considerations:

What is the relationship between apparently patternless change, directional change, and cyclic change? How is it concerned with the length of time during which we are able to carry on observations? Let us try to set up a mental model to illustrate this relationship.

Imagine an intelligent animal, able to observe and record observations, belonging to a species with a life span of only 30 days. It would see 30 day-and -night cycles pass during its lifetime. It would be able to see only one complete lunar cycle, or parts of two such cycles. (The cycle of phases of the moon from full moon to full moon requires 28 days to complete.) At whatever season of the year our animal lived, however, day-to-day temperature changes would appear to it as patternless. Only by reading the historical records of its species would an individual be able to get some idea that directional change in daily temperatures took place with the seasons, and that an annual cycle of temperature changes recurred regularly over a period of twelve or so of its generations. It might try to understand these longer directional and cyclic changes by comparing them with the waxing and waning of the moon, and the lunar cycle which was observable during its lifetime.

Now imagine that the creature belonged to a species having a lifetime of about six months. It would live through several lunar cycles, and would be able to observe the directional change of daily temperatures through a couple of seasons. The annual temperature cycle, however, would be to it as the cold winters and hot summers of the last century, supposedly remembered by our grandparents and other old people, are to us. The historical records of the species would show that these cycles, which they themselves were not able to observe directly, had occurred regularly in the past.

Now we come to ourselves. We have no trouble relating the apparently patternless, daily temperature changes to the directional changes which we see in the seasons, and to the annual seasonal cycle. These all lie within our range of experience. There is some indication, however, that young children may be less able to deal with the concept of the seasonal cycle than older people, and that primitive people dealt with it less readily than people who keep historical records. Some primitive people used the lunar cycle rather than the annual cycle to measure time. Possibly they understood this shorter cycle more readily. For us, climatic cycles, recurring at intervals of many years or many centuries, or even longer periods, are a subject of research and are somewhat controversial. How do you think climatic cycles would appear to a creature with a life span of 10,000 years?

The history of the universe and the evolution of life within it, appear to us to constitute directional change. We base our belief that this is so on all of the evidence that science has been able to collect by means of long and painstaking research. Do you think that there is a possibility that these too might be a part of still longer-term cyclic changes, if only we could look at them over a long enough period of time?

The Emergence of Patterns

Introduction:

Scientists look for patterns in nature, and then try to find their causes. If the patterns are consistent, they can be described in terms of natural laws. The principle of consistency lies back of all of the natural laws that have ever been discovered. A scientist assumes consistency when he observes nature or conducts experiments.

Patterns occur in living nature as well as in physical nature. Physical nature generally contains fewer variables, and therefore is usually simpler. The laws which describe it are more easily observed and understood. Living nature contains a greater number of variables. The laws which describe it are more complex, and more difficult to study and verify. All natural laws are based on the operations of consistent patterning factors.

Natural laws differ from civil laws in that they describe, while civil laws prescribe. Civil laws prescribe what people must do. If people do not obey them they are punished. Natural laws describe what nature does do. If it is discovered that a natural law does not accurately describe nature, the law is changed.

Materials and Equipment:

Iron filings

Magnet

A sheet of stiff paper

Wind-borne seeds: dandelion, milkweed, or other

An open area: school ground, vacant lot, road side, railroad right-of-way, or other, having a diversity of habitats, and containing a variety of different kinds of plants

Procedure:

1. Scatter iron filings evenly over the surface of a sheet of stiff paper. Hold a magnet against the lower side of the paper. What is the behavior of the iron filings? Does a recognizable pattern emerge from the formerly patternless condition of the filings? Move the magnet around. What happens?

Repeat the experience several times, starting in each case with the iron filings scattered evenly over the paper. Is the pattern which is formed consistent in every case? Describe the pattern. What causes it? Is there a natural law which describes this phenomenon?

2. Go into an open area containing as wide a variety of habitats as possible: bare ground, grass-covered ground, low weedy vegetation, tall weedy vegetation, etc. Choose a time when a moderate breeze is blowing. Too strong a wind will endanger the success of the experience. Set free at head height the wind-borne seeds from the

head of a dandelion, the pod of a milkweed or other available source. Watch how and where the seeds are carried by the wind. Follow them until they finally reach the ground.

Locate as many of the seeds as possible, up to 100. Describe the spot where each seed fell. How many different kinds of habitats are represented? How many seeds fell in each kind of habitat? Do you think the seeds would grow equally well in all of the habitats? Why or why not? Would they grow in some habitats and not in others? In which of the habitats do you think they would be most likely to grow? Why? Least likely? Why?

Was there a pattern in the original distribution of the seeds by the wind? Assuming that the seeds would germinate and grow in some habitats and not in others, would there be a pattern in the distribution of the plants that grew from the seeds? What would cause the pattern? Assuming that the situation which you have observed is typical for areas of this kind, could you describe the pattern of distribution of the particular species of plant that you are studying, and give a reason for it?

Study the actual distribution of the vegetation on the open area where you scattered the seeds. How many different kinds of plants can you find? (NOTE: You do not need to identify them.) Are they all evenly distributed over the area, or are some of them found in some places and not in others? Is there any apparent reason why they are distributed as they are? Is their distribution consistent? Are the same kinds of plants always found in the same kinds of places? How would you account for their distribution? Would you say that there was (or was not) a pattern in their distribution? Why or why not?

Is there a pattern in the different kinds of vegetation occurring naturally (not planted or cultivated) in your locality? What factors cause it? Is there a pattern in the distribution of different kinds of vegetation in North America? What is the nature of the pattern? What factors cause it? Are there natural laws which describe the distribution of vegetation?

3. What similarity is there between the portion of this experience dealing with the magnet and the iron filings, and the portion dealing with the wind-borne seeds and the distribution of vegetation? Why?

Further Considerations:

Can you think of other situations involving patterns in nature to which you might apply the same kind of analysis that you have used in the case of the magnet and the iron filings, and the distribution of plants? What about some aspects of human behavior? Of the behavior of other animals? What about weather?

Decomposition of Materials*

Introduction:

All natural materials undergo decomposition. This is true even of rock, which ultimately is broken down to sand or clay. Materials which have been a part of living organisms (plant or animal) break down relatively rapidly. Some, however, break down more rapidly than others. Also, the medium in which they happen to be found may affect their rate of decomposition.

Soil consists of finely divided particles: ground-up rock or "rock flour," mixed with partially decayed vegetal material called humus. The humus develops from the decay of the bodies of plants and animals through the agency of bacteria, molds, earthworms, soil insects, and even burrowing mammals. These organisms contribute to the breaking down of the dead bodies directly, or mix the dead material with already existing soil, permitting the organisms of decay to come in contact with them and attack them more readily.

In this laboratory experience you will have an opportunity to observe comparatively the decomposition of animal, vegetal, and man-made materials in contact with sand and soil.

Equipment and Materials:

Four medium-sized flower pots
Deep dishes in which to set the flower pots
Glass covers for flower pots
Washed sand
Rich garden soil
Small stones or pieces of broken flower pot
Dead leaves
Bits of cooked meat
Bits of bread
Bits of cotton fabric
Bits of wool fabric
Bits of nylon fabric

Procedure:

Note: This experience may be done in teams of two to four students, involving the entire class, or it may be set up as a demonstration for the class.

1. Place small stones or pieces of broken pot in the bottoms of the flower pots. Fill two of them to within an inch of the top with moist, washed sand, and the other two with rich garden soil. Press both sand and soil down firmly.

*Adapted from High School Biology, BSCS Green Version, Student Manual, Laboratory and Field Investigations, Rand McNally and Company, 1963.

2. On the surface of the sand in one of the pots place bits of dead leaf, cooked meat, and bread. Put each of these on a different area of the surface, keeping them as widely separated as possible. In the other sand-filled pot, place a bit of cotton fabric, a bit of wool fabric, and a bit of nylon fabric. Again, keep them separated.
3. Place the same materials on the surface of the soil in the two soil-filled pots, keeping them separated.

Note: You may place enough of the sand or soil on top of the materials in each pot to hold them in place.

4. Place all four pots in deep dishes containing water. Cover them with glass covers. Put all of them in a warm dark place. Keep the soil and sand moist at all times by adding water to the dishes containing the pots.
5. Observe the materials once each week for an extended period. Compare the appearance of the different materials. Look for masses of mold mycelium.

Note all changes.

Keep a record.

6. What is decomposition? What kinds of substances can be decomposed? What kinds of substances cannot readily be decomposed? What causes decomposition? Which of the materials that you are testing are decomposed most rapidly? Most slowly? Why? What differences are notable in the rates of decomposition of the same materials on sand and soil? Why? What is soil? How is it formed? What is humus?
7. What is the significance for the continuation of life on the earth of the kinds of change which you have observed in this experience? For maintenance of the "balance of nature"?

Further Considerations:

Go into a deciduous forest (a forest that loses its leaves in the fall, and grows them again in the spring). Locate an area where there is a thick covering of dead leaves on the forest floor. Note the condition of the leaves at the surface of the dead leaf covering. When did they fall? Dig carefully into the deeper portions of the dead leaf covering. What is the general condition of the leaves as you dig deeper? Can you pick out the "layers" within the dead leaf covering which fell a year earlier than the top ones? Two years earlier? Three years earlier? At what point do the leaves lose their identity and merge into the general mass of humus? Dig down into the soil. Note how the humus merges and becomes mixed with it. Dig down deeper. How thick is the layer of top soil (A-layer)? What is the B-layer and how does it differ visibly from the A-layer? What lies beneath the B-layer? What is "parent material" in connection with soil? What kinds of living organisms did you see as you dug down through the humus and into the soil? Which of these organisms played a significant part in the process of decomposition? How many different kinds of soil are there in your locality? How are they different? Why are they different?

V

Idea of Normal Curves and Warping Factors

1. **Idea-Bridge: Thinking About Normal Curves, Warping Factors, and, Sampling**

2. **Laboratory Experiences**
 - a. **Normal Curves and Warping Factors**
 - b. **A Study of Wind**
 - c. **Normal Curves Describe Variation in Nature**
 - d. **Use of Normal Curves in Distinguishing Species**
 - e. **Guessing Cards**

Thinking About Normal Curves, Warping Factors,
and Sampling

In the natural world, related phenomena tend to vary in pattern fashion around a norm. If you collect a representative sample of any particular kind of data: the grades, or weights, or height measurements of students of a particular age and sex group, the sizes of beans of a particular sort, the temperature at 3:00 p.m. each day in the month of January of a particular year, the readings from a measuring instrument for a supposedly uniform physical factor, allowing for margin of error, you will see this patterning around a norm.

You can record such data in the form of a graph. On it, the norm will appear as the central point on the base line of the graph, and each datum will be a point at an approximate distance on one side or the other of the central point. When you do this, the data will "pile up", most of them at or near the norm, the others with decreasing frequency at greater distances on each side of the norm. If the sample is large enough, and if there are no factors operating to warp the distribution, the resulting pattern will be in the form of a "bell curve" or normal curve.

Warping factors may include such things as: sex of students in a mixed class, wind blowing more frequently from a particular direction in the case of wind-scattered seeds, dice that are heavier on one side than the others, protective coloration in a species subject to being caught and eaten by predators, a catalyst causing a reversible chemical reaction to go more rapidly in one direction than the other. Such things interfere with the haphazard occurrence of data and produce a warped pattern or distribution curve. Scientific laws are descriptions of the operation of such constantly-operating warping factors in the natural world.

For phenomena to exhibit "normal curve" behavior, or for the operation of warping factors to be apparent, a sufficiently large and representative sample or collection of data is necessary. How large is an "adequate" sample? How do we know when it is "representative"? In general, we believe that it is sufficiently large and representative when the continued addition to the sample of randomly chosen individuals does not change the picture presented by the graph.

What kinds of phenomena can you think of that exhibit "normal curve" behavior? What kinds can you think of that show the action of warping factors? How are normal curves and gradients related?

Normal Curves and Warping Factors

Introduction:

This laboratory experience bears somewhat the same kind of relationship to the process of scientific investigation and the generalizations that result from it (hypotheses, conclusions, natural laws) that bridge-playing bears to real-life competition in business or politics, and that chess-playing bears to military tactics and war. What is this relationship?

Materials and Equipment:

Pennies

Masking tape

Graph paper

Procedure:

Toss a single penny not less than 100 times. Record the number of times it falls heads and tails. Are the numbers equal? If so, why? If not, why? Formulate a hypothesis to explain your results. Devise an experiment or set of experiments to test your hypothesis. Compare your results with this penny to the results of similar experiments with other pennies. Are the results the same? If so, why? If not, why? Formulate a hypothesis. Test as before. Does the age of the penny have anything to do with it? If so, why? If not, why? Try tossing a nickel. Does the kind of coin you use affect the result? What else might affect the result? Investigate some of these possibilities.

Continue your hypothesis-forming and testing as long as you find it interesting, or as long as time will allow. Do not worry if you do not come to any definite conclusions, or if the conclusions you arrive at on the basis of your own experience differ from those of others. The conclusions that you reach are less important than the procedure by which you reach them. You are actually not carrying your experiments far enough in any case to justify drawing well-established conclusions. Why?

What does a scientist mean by sampling? How is this related to what you have been doing? How well can you predict a final result after 20 tosses? 50 tosses? 100 tosses? 1,000 tosses? How large a population of boys or girls would you need to consider in order to make a well-founded generalization concerning them?

What is a hypothesis? What is a natural law? What is inductive thinking? Deductive thinking? Where have you used each type of thinking? What is an experiment? How is it related to an observation? To what extent is science experimental? To what extent observational? What is a controlled experiment? How does it differ from an uncontrolled experiment? From an observation?

Now take an even number of pennies (6-10), and toss them together, counting the total number of tails that show each time. Do this as many times as possible, up to 100. Record your results for each toss in such a way that the data for your total number of tosses forms a curve:

				X						
				X	X	X				
Number				X	X	X	X	X		
of Tails:				X	X	X	X	X	X	
				<hr/>						
				0	1	2	3	4	5	6

Transfer your results to a piece of graph paper. How closely have your results approximated a normal curve? Why? Any deviation from a normal curve is called a skewed curve, and is due to the operation of a warping factor. What are warping factors? Is a warping factor at work here. If so, what do you think it might be?

Calculate the total number of single-penny tosses involved in your result. Did heads or tails predominate in your mass result? Does this outcome support or contradict the conclusions you reached in working with single pennies? In case the two conclusions do not agree, which do you think would be the more valid? Why?

Put a thickness of masking tape on the head side of a penny. Be careful that the tape does not extend onto the edge of the penny. You have now introduced a possible additional warping factor into your penny tossing. Why did you need to be careful not to get tape on the edge of the penny?

Toss the penny at least 100 times as you did before. Record the number of times it falls heads and tails. Have you succeeded in warping the heads-tails ratio by attaching the tape to the head side? If so, to what extent? Now try adding a second layer of tape. Repeat the tosses. Is the ratio changed? Add a third thickness and try it again. Add a fourth and repeat. Is there any evidence of a progressively increased degree of warping? If so, is the change consistent?

Put a predetermined amount of tape on each of six pennies and toss them together as you did with untaped pennies, counting the total number of tails that show each time. Do this as many times as possible, up to 100. Record your data in such a way that your results form a curve. Transfer your results to a piece of graph paper. Does the warping factor which you have introduced show up in the form of a warped or skewed curve? Compare this curve with the one obtained from tossing six untaped pennies. Is there a difference?

Can you arrive at any sort of generalization concerning your results in tossing single pennies and six pennies without tape and with tape?

Further Considerations:

When examples of variation with regard to a particular characteristic in a sample population are quantified, and their frequency is recorded on a graph, the result may be a normal curve. In such cases we say that,

with regard to the characteristic being studied, the individuals making up the population vary around a norm. How does this differ from a patternless distribution? What factor or factors produce the pattern? Are these warping factors operating upon a patternless distribution?

What kinds of phenomena in biological and physical nature are describable in terms of a normal curve type of distribution? Can you think of some of these that you might survey, or investigate in the laboratory? What about height and weight in adult men and women? In boys and girls of the same age? Any others?

See if you can think of warping factors at work in biological or physical nature. Can you survey the operation of some of these, or try them out in the laboratory? What about degree of cloudiness in relation to temperature in a particular month? What about sex in relation to variations in height of men and women? Any others?

What is the relationship of normal curves and warped curves to the general phenomenon of patterns existing in nature? What kinds of patterns are there other than these two? What kinds of factors cause patterns? What is the relationship of patterns in nature to hypotheses? To natural laws?

A Study of Wind

Introduction:

People who live in rural areas, and other people who work outdoors, are generally more conscious of the direction and force of the wind than those who live in cities, and whose work is in schools and offices, and factories. Many of the latter are only conscious of the wind when it reaches gale proportions, or drives rain, or drifts snow, or when they see in television news reports the effects of a hurricane in Florida.

The wind, however, actually blows nearly all the time. Periods of complete windlessness do occur, but they are usually of brief duration. Even on a calm day, there is nearly always a breeze.

The direction from which the wind blows is intimately related to the general state of the weather, warm and cold fronts, and the movement of great continental air masses. The behavior of these is, of course, in turn related to geographic location, and to the march of the seasons. Local features of geography, such as mountains, lakes, and nearness to the seashore, affect local winds. The behavior of the wind is also related to time of day.

It is possible, by careful observation and record-keeping, together with a study of weather patterns, and the relation to these to local geography, to determine some of the factors that affect the behavior of the wind.

Equipment:

A weather vane mounted in a location where the wind can reach it freely from all directions. The material of which it is constructed should be sufficiently light, and its mounting of such a nature that the slightest breeze will cause it to turn on its axis and point the direction from which the wind is blowing.

A compass for checking directions.

Procedure:

1. Observe the direction of the wind, as indicated by the weather vane, every day at the same time for a series of successive days. The longer the period of observation, the better and more interesting will be your results. Check the direction with the compass, if necessary. How steadily does the wind blow from the same direction?
2. Summarize the results of your daily observations in the form of a graph. Let the horizontal axis of the graph represent the points of the compass, starting at the left-hand side with East, and proceeding around the compass clockwise. The reason for arranging the points of the compass in this order is that storms generally pass across the continental United States from west to east, or from northwest to southeast. Why is this?

Let the vertical axis of the graph represent the number of days that the wind was blowing from a particular direction at the time of the daily observation.

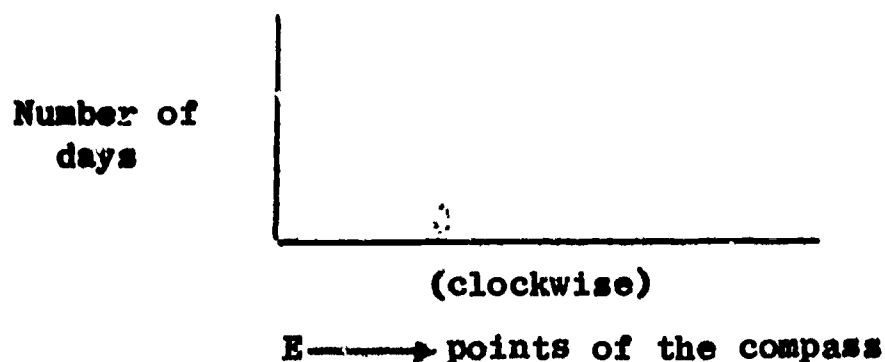

3. From what direction did the wind blow most frequently? Least frequently? If no warping factors were at work influencing the wind direction, one might expect, on the basis of pure chance, that the wind would be as likely to blow from one direction as another. Over a long period of time, therefore, the number of days that the wind would blow from each of the points of the compass would be the same.

Since it actually did blow more frequently from some directions, and less frequently from others, it is obvious that some warping factors were at work. What were they? See how many of them you can find or figure out. Listen to weather reports and forecasts on radio and television. Consult daily weather maps in the newspaper: How are these related to wind direction? See if you can find a relationship between the prevailing wind direction and your location with regard to the general geography of the North American continent. Is there a relationship with local geographic factors: lakes, rivers, nearness to mountains, seacoasts, et cetera? Is there a relationship to season of the year?

4. For a series of successive days (as long a period as possible) observe and record wind directions at hourly intervals from a time as early in the morning as possible to a time as late as possible in the afternoon or evening.
5. Construct a series of graphs, one for each hour of the day when observations were taken. Again let the horizontal axis represent points of the compass, while the vertical axis represents the number of observations of wind blowing from each direction at that particular hour on different days.

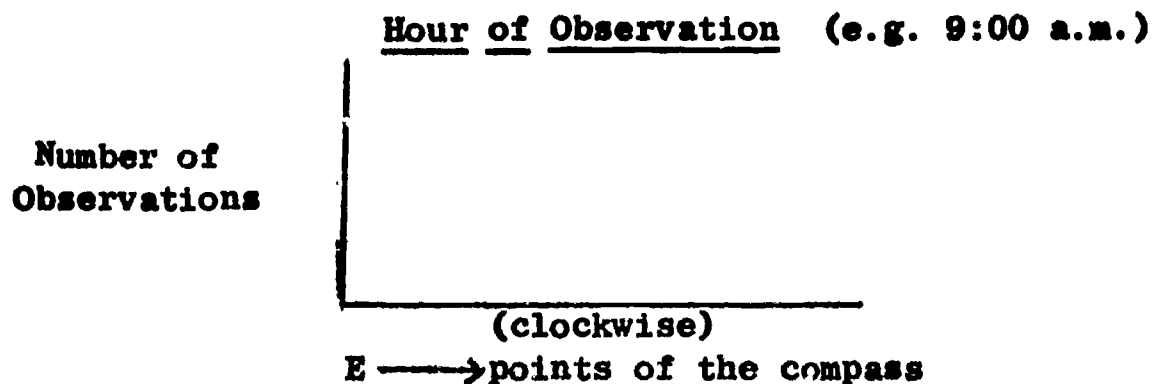

6. How much shifting in wind direction generally takes place in a single day? To what extent do days differ in this regard? Why? How slowly or how rapidly do shifts in wind direction take place? To what factors can you relate these changes in wind direction? Consider the same possibilities of relationship that are indicated under (3) above.

7. What conclusions can you draw as to the warping factors that determine wind direction in your locality? Cite evidence from your records to support your conclusions.

Further Investigations:

Repeat your study at different seasons. What differences do you find? Why?

Velocity of the wind is measured by an instrument called an anemometer. If one of these instruments is available or can be obtained, determine wind velocity at the same time on successive days, and at different hours of each day for a series of days. See if you can relate velocity of the wind to the factors listed under (3) above. How does wind rise and diminish or cease? Why? Slowly or suddenly? What causes wind? What determines wind velocity? What kinds of winds are there?

*Normal Distribution Curves Describe Variation in Nature

Introduction:

There is variation in everything. Sometimes we are able to account for these differences. More often we are not able to do so. They are accepted as a fact of nature. Darwin assumed as a fundamental fact that no two living organisms are alike. He made this one of the bases for his theory of evolution through natural selection. Darwin did not know about genetic mutation, which we now know interacts with the environment to cause variation.

In nature, even among offspring of the same parentage, the interplay of genetic and environmental factors results in a wide range of variation among organisms of the same kind. It is rarely possible to adequately describe two or more living things by saying that they are "as alike as two peas in a pod". Even in cases where we can do so, close inspection and measurement will show that there are detectable differences. Among people only identical twins are nearly alike. They possess identical heredity, but even with them, slight differences may occur due to the influence of environment.

One way to see the occurrence of variation and its distribution in nature is by measuring a collection of lima bean seeds.

Materials and Equipment:

- 1 lb. dry lima bean seeds of the same kind
(either large or "baby" limas)
- 12 large test tubes and a test tube rack (4 oz. fruit juice glasses or wine glasses may be substituted, if they are made of clear, transparent glass)

Magnifying glass

Millimeter rule

Glass marking pencil

Graph paper

Simple balance measuring weight in grams and fractions of grams

Procedure:

This experience is best carried out by individual students or by students working in pairs. The final results obtained by the individuals or pairs may be combined at the end of the experience to provide a larger sample.

*In collaboration with Dr. Sylvan Mikelson, School of Education, Wayne State University, Detroit, Michigan, and his graduate students.

Measure the beans in groups of ten. Each "ten" should be selected at random, e.g., counted as they are poured out of a bag or other container.

Measure the greatest length of each bean with the millimeter rule. Determine the length to the nearest millimeter, using the magnifying glass for close distinction. You will soon develop a skill in doing this, such that the job will proceed relatively rapidly.

When you have measured the first bean, file it in a test tube or glass, and mark the length on the glass. Do this with the second bean, if it is a different length, or file it in the same container if it is the same length. Continue until you have completed the first group of ten, setting up a new container every time you find a bean of a different length. Do your containers form a continuous series (e.g., 12 mm., 13mm., 14mm., 15mm., 16mm., etc), or is the series incomplete? Have the beans begun to "pile up" in one of the containers? When they do so, the length which occurs most frequently is called a mode. Where is it located in the series? Is there more than one mode? Write down your answers to these questions.

Measure a second group of ten, proceeding as before. When you have completed it, answer the same questions asked at the completion of the first group of ten, and record your answers. Are the answers the same? If they are different, in what ways do they differ? Continue with a third group of ten, record the answers. Follow with additional "tens", as long as you have time to or care to continue the experience. Keep a record of the number of "tens" that you have measured.

How many "tens" did you have to measure before new size classes ceased to appear? How many "tens" did you have to measure before a definite mode became apparent? In which "tens" did you find the longest and shortest extremes of the population? Does this tell you anything about the probability of pulling a single bean at random from the population, which would be representative of one of these extremes? When a single specimen of an extinct race of man is discovered which differs widely from modern man, what do you think of the argument that it is a "freak"? How valid do you think it is to generalize on the basis of a single, interesting case in dealing with any kind of data?

How many "tens" do you think it took to constitute an adequate sample of the bean population? Would your conclusions concerning the nature of the population have changed if you had continued beyond this point? Try to frame a definition of an "adequate sample" which would be applicable to any kind of population.

Count the total number of beans in each size class, and construct a graph showing the relationship of sizes to the numbers in each size class.

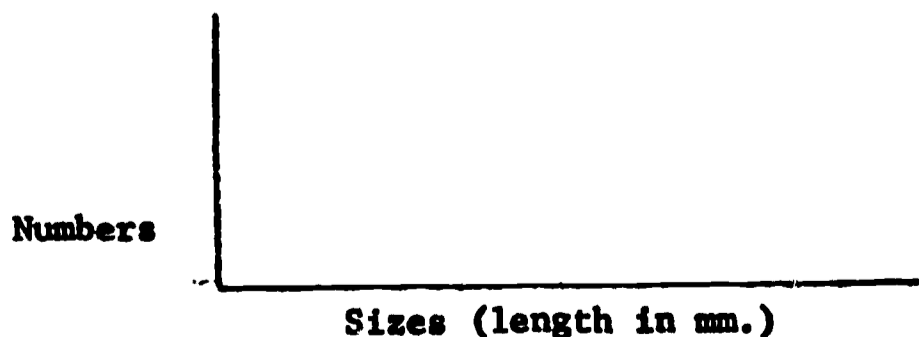

To what extent does the graph showing your results approximate a normal curve? Would measurement of a larger sample have given you a better curve? On the basis of your graph, do you wish to modify your conclusions concerning the size of an adequate sample? Do you wish to add to, or modify your definition of an adequate sample?

Combine the results obtained by other members of the class. Construct a similar graph showing results from the entire class. Do you get a better curve? If so, why? Is there a change in either the extremes of the population or the mode when the results of the entire class are combined? Do you wish at this time to further modify your conclusions concerning the size of an adequate sample?

Further Considerations:

How do political poll takers determine what constitutes an adequate sample? What factors in addition to size of the sample do they have to take in consideration? How accurate are their results?

As you measured the lima beans, did you notice any other kinds of variation other than length of the seed? How about width of the seed? Shape of the seed? If you were to weigh all of the seeds in each size class, or an adequate sample of them, do you think that the weight of each seed would necessarily bear the same relation to their common length? Or would there be a normal curve of different weights within each size class? Try this and see, if you have available a simple balance, measuring weight in grams and fractions of grams.

What about other kinds of seeds? Nuts? Fruits? Leaves? What about various kinds of common animals? What about humans? Is the kind of variation which you have studied in lima beans characteristic of all forms of life? Do you think that you could set up normal distribution curves for variation occurring in other living things? Try it in any case where you can obtain a sufficiently large population to constitute an adequate sample.

What about variation in non-living things in nature? What about variation in things that man has made? How would you describe variation in the classes of things that man has made? Does it differ from variation in living nature? In non-living nature? How? Why?

Can variation among living things be related to survival in nature? How? What would be the equivalent of "survival" in the case of man-made things? Would the equivalent of "variation" in the case of man-made things be related to this? How?

The Use of Normal Curves in Distinguishing Species

Introduction:

Since 1930, Dutch elm disease has destroyed large numbers of our native American elms (Ulmus americana). This disease is caused by a fungus which is carried by a bark beetle. The introduced Siberian elm (Ulmus pumila), sometimes erroneously called Chinese elm, is much less susceptible. This species has been planted in this country as a shade tree for at least a generation. It is now well established, and in many places it is reproducing naturally.

Materials and Equipment:

Millimeter rule

Means of pressing leaves or making prints of them

Graph paper

Procedure:

Collect (by cutting the leaf stem or petiole near the base) 100 full-size leaves from each of the two species of elm trees. Press the leaves carefully, or make accurate prints of them. Make the following measurements and observations on each leaf:

- (1) greatest length (not including the petiole)
- (2) greatest width
- (3) number of notches on each side of the leaf. (In the American elm leaves consider only the large notches.) Record the right and left sides separately. In determining "right" and "left", place the leaf top-surface downward, and consider right and left to correspond to your own right and left hands.

Summarize on graph paper all four kinds of data obtained from measuring and counting. Use a single sheet for each kind of data from the two species, recording the data from one species in red and from the other in blue or black. This will help you to compare the two species for the characteristics which you have studied. Plot on the graph the measurement or number of notches against the frequency with which it occurred in your population of 100 leaves.

(1)
Number of leaves

Leaf length in millimeters

(2)
Number of leaves

Leaf width in millimeters

2.

(3)

Number of leaves

Notches on right side

(4)

Number of leaves

Notches on left side

How closely does each kind of data for each species approximate a normal curve? How much overlap (if any) occurs between the two species in each case? What conclusions would you draw from this as to the nearness of relationship of the two species? Can you write a general description of each species from the data that you have, in such a way that a person seeing them in nature could readily distinguish them? Try to do so. These are the kinds of data that taxonomists use in describing species and distinguishing them from one another.

Further Investigations:

What is a species? Can you set up similar comparative studies for other species? What about species of dogwoods? What about hawthorns? What about oaks? Note that this kind of study is valuable only for two closely related species. More distantly related species are readily distinguished by characteristics which do not overlap.

What is variation? Can variation be related to survival in nature? How? What effect would this relationship of variation to survival have on the characteristics of the species itself if continued over a long period of time?

Guessing Cards

Introduction:

As you probably know, a deck of ordinary playing cards consists of 52 cards. There are four suits of 13 cards each: hearts, diamonds, clubs, and spades. Therefore, if you attempt to guess the suit of any single card chosen at random, you have one chance in four of guessing it correctly. If you shuffle the deck each time before drawing a card and guessing, you should expect to be right in 25 percent of the cases, 25 right out of 100.

Any percentage of correct guesses higher or lower than 25 percent would seem to indicate one of two things, either (a) inadequate sampling, i.e., although this particular trial run exhibited a significant departure from expectation on the basis of pure chance, if enough runs were considered, the results would show chance expectation, or (b) the operation of some warping factor of yet undetermined nature.

Theoretically, it should make no difference whether the increase in the number of trial runs is achieved through a series of a great many runs carried on by the same person, or through combining the results of a large number of single runs carried on by the members of a fairly large group, such as the members of a class. If both of these methods of achieving an increase in the number of runs are used, and the results of the two methods are compared, the possibility of the operation of a warping factor in the guesses of one or more individuals within the group can be studied.

If such a warping factor appears to be operating in the case of one or more individuals, the only way of strengthening the evidence for its existence would be to greatly increase the number of runs for these individuals. The nature of such a warping factor, if one were found to exist, would still not be ascertainable.

Equipment:

A pack of playing cards. The newer the cards the less is the danger of their carrying any identifiable marks or clues.

Sheets of paper numbered one to 20

A watch with a second hand

This set of items will need to be replicated for each team carrying on the experience.

Procedure:

Individuals will work in trios. One member of the trio holds nothing. He is designated as the "Number One" individual. A second member holds a deck of cards and a watch with a second hand. He also has a sheet of paper numbered one to 20, and a pencil. He is designated as the "Number Two" individual. The third member holds only a numbered sheet of paper and a pencil. He is designated as the "Number Three" individual.

Number Two shuffles the cards thoroughly, and holds them while Number One draws a single card from any portion of the deck. Number One looks at the card and concentrates on it. Number Three also concentrates, thinking about the card that Number One holds without seeing it, and attempting to guess to what suit it belongs. Number Two looks at the watch and allows One and Three to concentrate for a minimum of five seconds. At the end of this time, One shows the card to Two, who writes down the suit of the card on his sheet of paper in the space marked "1." One checks the correctness of the suit that Two has written down. Three writes down what he guesses the suit to be in the corresponding space on his sheet of paper.

The trio repeats this action, shuffling the deck each time a card is drawn, until One has drawn cards, and concentrated on them, and Three has guessed them, 20 times. Then, Two writes One's name on his paper, designating himself as "guesser." No comparison of the sheets is made at this time. They are given to the teacher or other person in charge to hold for final tabulation.

The members of the trio now exchange jobs. Number One becomes Number Two, Number Two becomes Number Three, and Number Three becomes Number One. The procedure is repeated, with each person filling a new job. This is continued until each person has filled each of the three jobs at least once. Since it will not be possible to complete this cycle in a single period (Why might it be desirable to do so from the experimental standpoint?) the work should be taken up the following period at the point where it was left off. It would be desirable for each person to serve in each capacity five times (five runs of 20 each equal 100), if this is possible. Any number of times, 20 to 100, may be used, however.

It would be well not to tally the results of the experience as recorded on the sheets until the entire experience is completed. The teacher should then compare the series of sheets prepared by each "viewer" and "guesser" (pair), and tabulate the results for class inspection.

How closely did the results in the case of each student in his role as "guesser" correspond to chance expectations? Were there as many individuals whose guesses were less frequent than chance as there were those whose guesses were more frequent than chance? When the results from all individuals in the class are put together, how closely do they correspond to chance expectation?

Were there any individuals whose guesses were very greatly in excess of chance expectation? If these individuals took part in more than one cycle, on different days, were their results consistently high? Were there any individuals whose guesses were markedly less frequent than chance expectation? If these individuals took part in more than one cycle on different days, were their results consistently low?

Do you think that any warping factors were at work in the card guessing which took place? Do you have any hypotheses as to what these warping factors might have been? Is there any evidence that people can read each other's minds? That some people can read minds, while others cannot? What do you think about the whole business of extra-sensory perception? What complications would exist in society if mind reading were really possible?

Further Experimentation:

Try additional runs for individuals who have shown much greater-than-chance and much less-than-chance guessing ability. Have them work with different partners than they did before. Does their performance remain consistent?

Try having Number One draw the card and concentrate on it without turning it over to see what it is, then, still without looking at it, showing it to Number Three who writes it down. Compare the lists prepared by Number Two and Number Three as before. How do the results compare with those obtained when Number One looked at the face of the card while he concentrated on it?

Try having the "guesser" concentrate on a deck of freshly shuffled cards and guess the suits of each of the top 20 cards as they lie in the deck without removing them. Try the same thing before the cards are shuffled. See if the "guesser" can predict the order that the top 20 cards will be in after they are shuffled. What are telepathy, clairvoyance, and precognition? How do they differ from one another? What evidence is there for the existence of each?

Try to see if it is possible to influence the fall of a pair of dice by concentrating on them. Figure out the combinations of dice which fall most frequently with normal chance expectancy. How can you do this? Try having one person throw the dice and another attempt to influence the way they fall by concentrating on them. What is telekinesis? Is there any evidence for its existence?

VI

Idea of Gradients

1. Idea-Bridge: "Thinking About Gradients"

2. Laboratory Experiences:

- *a. "A Gradient: The Effect of pH on Yeast Activity"
- *b. "A Growth Gradient in Nature: An Experience for Early Spring"
- *c. "A Gradient for the Separation of Pure Chemical Substances: Paper and Thin Layer Chromatography"
- *d. "A Simple Learning Curve"

*Included in Bulletin No. 313, NDEA Title III, Open-Ended Laboratory-Centered Science for Grades 7-8-9. Michigan Department of Public Instruction, Lansing, Michigan, 1965.

Thinking About Gradients

There are no sharp boundary lines in nature. Related classes of natural phenomena grade imperceptibly into one another in any area where they meet. This is true of related species of plants and animals, of races of men, of dull and bright children, and of physical phenomena, such as temperature, relative humidity, barometric pressure, light. It is true of the features of the earth's surface, such as slope of the land, height above sea level, salinity of bodies of water. It is even true of the chemical elements of which the natural world is made. They intergrade through temporarily radioactive isotopes that change into something else by the ejection of sub-atomic particles. Can you think of any classes of things that do not exhibit intergradation?

The natural world is not a world of "blacks" and "whites", for the zones between "black" and "white", in all cases, are occupied by various "shades of gray". A progression from "white" to "black", through all of the possible "shades of gray" that lie between, is called a gradient.

There are many good examples of gradients. There is a gradient of decreasing annual temperature as you go north from the equator to the north pole. There is a gradient of decreasing annual rainfall as you go west in the United States from the Atlantic Coast to the Rocky Mountains. There is a gradient of decreasing light from noon until an hour after sundown on any particular day. A stream exhibits a gradient of decreasing elevation above sea level from its source to its mouth. A child shows a gradient of growth in height from its birth to adulthood. There are gradients of increase and gradients of decrease, rising as well as falling gradients. There are many gradients of change from one state to another. All gradients exhibit continuous directional change. The process of learning exhibits a gradient of increasing skill or other change. Evolution is a gradient of directional change through time.

How many different gradients, or kinds of gradients can you think of?
Can you think of any sharp boundary lines in nature?

A Gradient: the Effect of pH on Yeast Activity

Introduction:

Nothing exists alone. Every living organism and every bit of non-living matter interacts with the things around it. Nothing stands still either. Everything in the universe is constantly changing. We can demonstrate that the kind and quantity of change which occurs in an organism is dependent on conditions of the environment.

One way that we can see this is by watching and measuring the amount of yeast activity, in terms of the amount of carbon dioxide (CO_2) produced, in environments of varying pH (acidity-alkalinity). A series of these environments can be constructed to constitute a gradient from extreme acidity to extreme alkalinity.

Materials and Equipment:

One cake or envelope of dried yeast (Red Star or Fleischman's)
Test tubes without rims: 2 sizes--13mm. x 100mm. and 18mm. x 150mm.
Test tube rack
pH paper, pHydron paper dispenser AB pH 1 to 11 (a standard lab item)
Test tube brush
Solutions: 6N Na OH* and 6N HCl*
Table sugar (sucrose)
Simple balance for weighing in grams
Graduate cylinder, 100 ml. (1 milliliter equals 1 cubic centimeter)
Centigrade thermometer
Five beakers or small jars
Two quart jars for dissolving sugar and yeast
Millimeter rule
Aluminaum foil for covering jars (if desired)
Wax pencil for labeling test tubes
Graph paper

Procedure:

Weigh out 50g. of sugar and dissolve it in 500 ml. of water at approximately 37°C. (or lukewarm to finger). This is approximately a 10 per cent solution.

Place yeast in 100 ml. of lukewarm water (approximately 37°C.). Stir to break it up and shake it well.

*To prepare a 6N solution of NaOH, dissolve 240g. of NaOH in enough water to make a liter. Since most commercial preparations of concentrated HCl are approximately 35 per cent hydrogen chloride, dissolve 600 ml. of concentrated HCl in enough water to make a liter.

From this point students should work in small groups. There should be five such groups, each working with 100 ml. of solution. Each group will obtain and work with a solution of different pH (pH 1, 4, 7, 9 and 11). A range of difference such as this is an example of a gradient. A pH of 1 is very acid, a pH of 7 is neutral and a pH of 11 is very alkaline (or basic). This gradient therefore ranges from extreme acidity to high alkalinity.

Each group should follow these directions:

1. Put 100 ml. of yeast-sugar solution in a beaker or small jar.
2. Adjust to the desired pH by adding NaOH or HCl, one drop at a time until the phytion paper indicates the desired alkalinity or acidity.
3. Put 20-23 ml. of this solution into each of three of the larger test tubes. If you pour a measured amount into one test tube, you may simply pour the others to match it.
4. The next step is tricky. Practice the procedure with plain water until you are sure that you can do it before attempting it with the yeast-sugar solution.

Fill the small tube with liquid from the 20-23 ml. quantity in the large tube.

Capsize it quickly in the large tube so that it is completely submerged, open end down.

Hold your thumb over the open end of the large tube and turn it upside down, so that all of the air in either tube is collected in the bottom (now turned upward) of the large tube.

Carefully turn the large tube upright in such a way that the bubble of air passes upward past the open end of the small tube without entering it.

The small tube is now completely submerged, open end down in the large tube, with no air in it.

Your yeast is now ready to carry on activity.

5. Label the test tubes according to pH, and place them upright in the test tube rack. Leave them at room temperature for 24 hours.
6. At the end of the 24-hour period, measure with millimeter rule the amount of gas produced in each tube. The gas produced is CO_2 , an end-product of the oxidation of the carbohydrate, sucrose. The amount of gas produced is an index to the amount of yeast activity (fermentation) which has occurred.
7. Compute the average amount of gas produced in the three tubes of the same pH.

Pool the data for all groups and record on graph paper, plotting millimeters of gas against pH value.

What is the optimum pH for yeast activity? Does the extent of yeast activity in the series of tubes constitute a gradient? If so, how would you describe it? What is the relationship of this to the pH gradient? Can you think of an explanation for what you observe? Is the extent of yeast activity the same in each of the three test tubes with the same pH. Why is the experiment more valid with three tubes of each kind rather than only one.

Further Investigations:

When you have determined the optimum pH for the activity of yeast, you may investigate the relationship of yeast activity to other gradients. Maintain the optimum pH, as you have determined it, and set up:

A gradient of nutrition using varying concentrations of sugar as a food source.

A gradient of salinity, using varying solutions of table salt (NaCl). Be sure to start with very dilute solutions at one end of your gradient.

A gradient of chlorination, using varying dilutions of commercial Clorox as a chlorine source. Here again be sure to start with very dilute solutions. Determine the killing point. How is this related to purification of water supplies?

Your original experiment will produce measurable results more quickly if you use heavier concentrations of yeast to seed the culture. See if you can get measurable results in a single class period in this way. Try a gradient of yeast concentrations at the optimum pH.

Your yeast will grow, as well as show activity at any particular pH, if you add a bouillon cube to the 100 ml. of yeast-sugar solution. This will furnish some nitrogen for the yeast to utilize in growth.

The natural world is full of gradients which interact with one another. There are no sharp lines in nature. Scientists think of nature as a continuum. Try to frame a definition of this word.

See: "Experiences with Bacteria in High School Biology," Sister M. Paulinus. O.P., American Biology Teacher, Volume 22, Number 6, Pages 325-332, June 1960.

*A Growth Gradient in Nature: An Experience for Early Spring

Introduction:

Near you is a wild cherry tree or perhaps an old apple tree which attracts tent caterpillars. They attack other species of trees also, but wild cherry and apple trees are common. The adult moth (Malacosoma americana) lays three or four hundred eggs in a band encircling a small twig of the tree. This band, about one-half inch wide, is rounded at the ends, and is covered with a waterproof, protective "varnish". The embryos develop before winter, but do not emerge from the eggs until the following spring.

Each student (or group of students) should record observations of one colony from the time the eggs hatch until the caterpillars leave the tent (about three or four weeks). Each student or group should locate three to five egg masses, to increase the chances of having selected a live one to observe.

Procedure :

Observe the colony before the eggs hatch and as soon as possible afterward. Record the length of 50 or more caterpillars at least three times a week (more often if possible). Make your observations at the same time of day, using as uniform methods as possible.

Record your observations on a record sheet (as shown). Note that the sheet provides space for recording weather information and the condition of the foliage of the tree.

While you are observing the growth of the caterpillars, you will discover many other interesting reactions and habits of these animals. As caterpillars eat and grow, they molt (shed their exoskeletons) several times. Do all the caterpillars of one colony molt on the same day? Find a caterpillar which is in the process of molting. Watch the old exoskeleton split and the caterpillar crawl out of it. Describe the process.

Watch a caterpillar eat. How does it eat? How does caterpillar feeding behavior vary with the weather (temperature, cloud cover, rain)? Sometimes you will find most of the caterpillars in the tent. At other times they are all out feeding. Can you make a generalization to describe the relationship of "all in" or "all out" with time of day, or with any physical environmental factor?

What, if any, is the relationship between time of emergence of the caterpillars and growth of leaves on the trees? How can you account for the trees being able to survive annual infestations of caterpillars? What kinds of birds, if any, eat tent caterpillars?

How do the caterpillars find their way back to the tent? Devise an experiment to test your answer. Where do the caterpillars go when they leave the tent for good? Where do they pupate? How long do they remain in the pupa stage?

*In collaboration with Dr. Beth Schultz, Department of Biology, Western Michigan University, Kalamazoo, Michigan.

When your field study is completed, plot on a sheet of graph paper the average lengths of the caterpillars from the colony that you have studied, for each day that you have measured them:

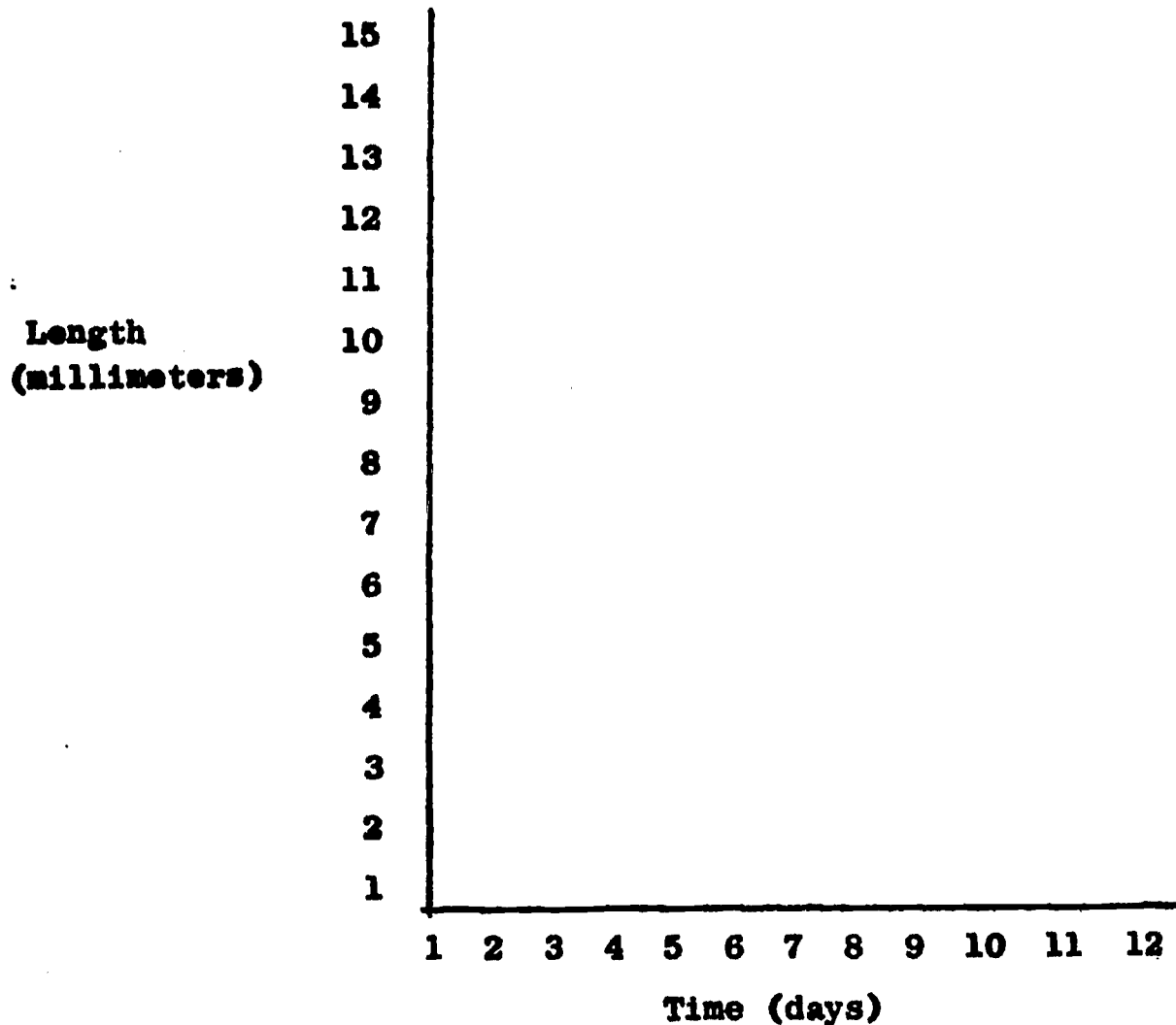

The graph that you have constructed will show the growth rate of the caterpillars. How will you know when they are fully grown? Is the gradient of growth the same for all colonies that the class has studied? Is the growth curve smooth, or are there irregularities in it? If there are such irregularities, how can you account for them?

Further Investigations:

What other growth gradients can you study? How would you go about studying growth gradients in humans? What environmental or other modifying factors would you look for in a human growth gradient? To what extent is it possible to account for differences in the growth gradients of individual humans? Plan an experiment to study a growth gradient in a green plant. What environmental modifying factors do you need to consider in making your plan?

*A Gradient for the Separation of Chemical Substances:

Paper and Thin Layer Chromatography

Introduction:

One of the most valuable techniques which biochemists have at their disposal for separating small quantities of pure substances from a mixture of similar chemical compounds is that of chromatography. Two applications of this are paper chromatography and thin layer chromatography. You can demonstrate these for yourselves, using any solution which consists of a mixture of similar compounds that show color.

A small quantity of the solution is placed on one end of a strip of filter paper, or on a thin layer of an absorbent substance on a glass microscope slide. A liquid (water or other) which will dissolve the compounds in the mixture is allowed to creep up the paper or the absorbent substance on the glass slide, to and through the spot where the mixture has been placed, and beyond it.

As the solvent creeps along, it pulls the components of the mixture with it. Each component, however, travels at its own rate. In this way the individual components become separated, and when the solvent dries, each is left in pure form apart from the others, so that each now makes a separate spot on the paper or slide.

In chemical analysis, each of the separated components may be removed and its quantity accurately determined.

Materials and Equipment:

Glass cylinder 150mm by 38mm (a glass bottle of comparable size may be used, but cylinders of this type may be purchased from Fisher Scientific Company at \$1.35 each, with a 10 per cent discount in lots of a dozen, catalog number 8-535.

Silica gel (this may be obtained from Brinkmann Instruments, Inc., Great Neck, Long Island, New York. The price is approximately \$6.00 per 500 grams.)

Filter paper cut into 1/2" x 4" strips

Rubber stopper, No. 8

Flat wooden tooth picks

Paper clips

Microscope slides

*In collaboration with Dr. Thomas F. Brodasky, and Dr. Stanley Owen,
The Upjohn Company, Kalamazoo, Michigan.

Two pieces of single strength window glass 1" x 6"

One piece of single strength window glass 4" x 8" (this and the preceding item can be cut in the school shop, or obtained from a local glass-cutting establishment.)

Food coloring, several colors (powder or in water solution)

Washable ink, several colors

Procedure:

This experience will require two or more laboratory periods. Work in groups of convenient size. If more than one cylinder or bottle is available several groups can test different solutions at the same time.

Paper chromatography:

1. Dip the small end of a wooden tooth pick one-third to half its length in the solution to be tested, and lay the narrowest dimension of it flatly across the strip of filter paper about three-fourths inch above the lower end of the strip, making a narrow band completely across the strip. It is important not to apply too much of the material. Too heavy application will result in poor separation of the components.
2. Bend a paper clip to form a small hook which can be affixed to the bottom of a rubber stopper.
3. Suspend the strip of filter paper from the rubber stopper by attaching the upper portion of it to the hook
4. Put a sufficient amount of water into the cylinder to allow the lower end of the filter paper to extend into the water. Be careful not to allow the water to come in contact with the material on the paper.
5. Place the rubber stopper carrying the strip of filter paper in the neck of the cylinder.
6. Allow sufficient time for the water to migrate up through the filter paper to the top.
7. Remove the filter paper and dry it as quickly as possible. What has happened? Compare the results of this technique, using as many colored solutions as you can.

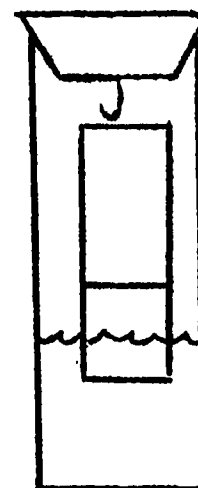

Thin layer chromatography:

1. Place the two 1" x 6" glass strips on top of the 4" x 8" glass plate.
2. Two microscope slides may be coated at a time. Place the slides end to end between the 1" x 6" strips.

3. Mix a small amount of silica gel with a small quantity of water. This will result in a mixture called a slurry, the consistency of which will be thicker or thinner, depending on whether you use more or less water. It is advisable to keep the slurry thin, since this will result in thinner films, which will produce better suspensions. Some experimentation may be necessary on your part to achieve a slurry which is of the right consistency to spread thinly and evenly, but not watery enough to run.
4. Pour a small amount of slurry on the microscope slides, and level it off by drawing a third slide across the 1" x 6" glass strips. Again you may have to experiment to find the right amount of slurry to use.
5. Allow a few seconds for the slurry to begin to set. Then remove the slides, wipe the glass pieces clean, and prepare more slides as needed.
6. It may be necessary to add a small amount of water to the remaining slurry from time to time, as it will begin to set. Be careful not to add too much.
7. Allow the thin layer plates which you have prepared to dry overnight. You may dry them more quickly with forced temperature conditions, but be sure that they are dried thoroughly.
8. Dip the small end of a wooden tooth pick one-third to half its length in the solution to be tested, and lay the narrowest dimension of it flatly across the slide about three-fourths inch above the lower end of the slide, making a narrow band completely across the slide. Do not apply too much of the material.
9. Place the slide in the glass cylinder, to which has been added a small amount of water. Be careful not to allow the water to come in contact with the applied material.
10. Place the rubber stopper in the neck of the cylinder, and allow sufficient time for the water to migrate up through the silica gel to the top of the slide.

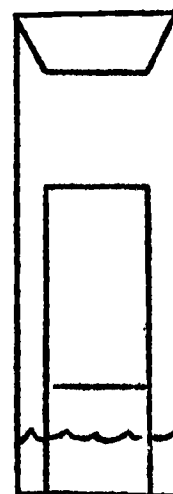
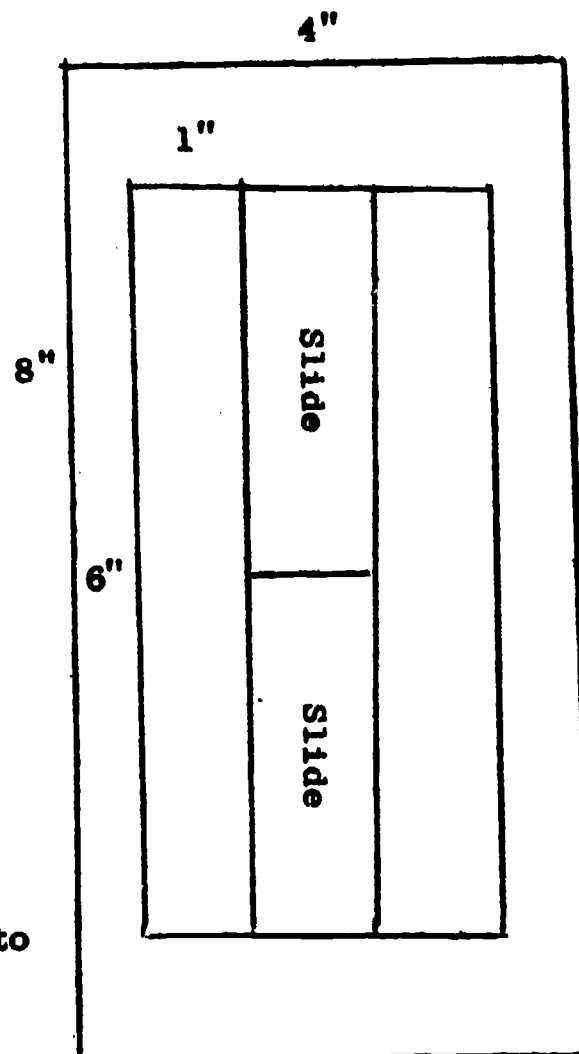

11. Remove the slide carefully and dry it as quickly as possible.

What has happened? Compare the results, using different colored solutions. Compare the results with those obtained from the filter paper. If you were planning to use chromatography as a quantitative method of analyzing the components of a mixture, do you think that one method might yield more accurate results than the other? Why? Can you think of any specific situations where one method might be better adapted than the other? Why?

Further Investigations:

Some substances are soluble in alcohol as readily as in water or more so. Others are not. Try dissolving food coloring or other pigments obtainable in powder form in commercial rubbing alcohol. How well does this work? Try the paper chromatography technique, using alcohol wherever water is indicated. What results do you get? Try the silica gel thin layer technique, using alcohol in all steps where water is indicated. What is the result? Explain any differences in results that you obtain.

How is chromatography (paper and thin layer) explainable in terms of a gradient? How could you quantify (express in terms of quantity) the amounts of each component in a mixture, separated by chromatography methods, without resorting to detailed chemical analysis? Remember that measurements are expressions of relationship.

How long has chromatography been in use by chemists? To what extent is it used in modern chemistry? Think of ways in which you might go about finding answers to these questions.

*A Simple Learning Curve

Introduction:

The process of learning a skill does not differ basically in animals, regardless of species. Psychologists use rats, pigeons, monkeys and other lower animals for experimentation in studying the learning process. When you set out to learn, however, you utilize the same process. A skill is improved by repetition and the rate and degree of improvement can be measured and recorded in the form of a curve on a graph.

When a scientist sets out to study a problem, he reduces the problem to as simple terms as possible. In order to observe the learning process at work in ourselves in readily measurable fashion, therefore, we choose a single simple task, and measure the increase in our skill in accomplishing it in terms of time.

Materials and Equipment:

Filing cards, 3" x 5"

Scissors

Envelopes

Stop watches (clocks or watches with visible second hands may be used, but will give less accurate measurements)

Graph paper

Procedure:

In this laboratory experience you will work in pairs. Draw straws or flip a coin to determine who will be "Student A" and who will be "Student B".

Both of you will cut a 3"x5" filing card into 10 pieces. The pieces should be approximately equal in size, and of as many shapes as possible. The cuts, however, must all be along straight lines. It is best to draw lines (lightly with pencil) to indicate the cuts before doing the cutting. The pieces should then be placed in an envelope marked with your name.

Student A now administers the test to Student B. He should rule a piece of paper with two columns. One column is headed Trial and the other is head Time. He should be provided with a stopwatch, or a clock or watch with a second hand. You are now ready to start.

Student A empties the envelope on his partner's desk, covers the pieces with his hand, and when Student B is ready, removes his hand and punches the stopwatch or notes the time in seconds on the data sheet. Then he mixes the puzzle again, covers it, and runs a second trial. This is repeated until Student B is not able to improve his time for three or four successive trials.

*In collaboration with Mr. David T. Smith, Coordinator of Science, Tucson Public Schools, Tucson, Arizona.

Record your results on graph paper as indicated in the following diagram, plotting number of trials against time.

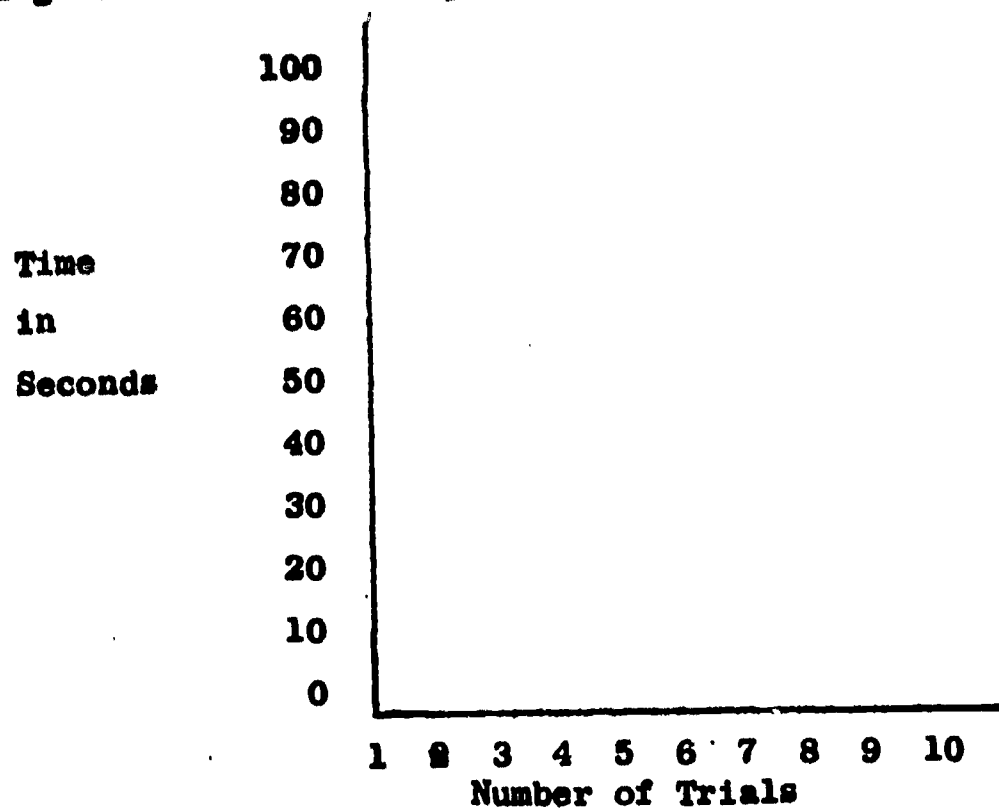

You now trade places. Student B administers the test to Student A, using the puzzle that he has prepared. All other procedure is the same.

Compare your results with those of your partner. Are there any differences? Try to account for them.. Compare your results with those of other members of the class. Try to account for any differences that you find. Are some puzzles more difficult than others? Was the technique of administration the same in all cases? See if you can make the conditions of the experience more uniform, and try it again. Try to devise an experience by which the relative speed of learning of all members of the class may be compared. If this is expressed in the form of a curve, what kind of curve would you expect to get? Does learning how to put one puzzle together improve your learning rate in putting together a second puzzle?

Further Investigations:

Try further tests of learning ability, utilizing more complex types of learning experiences. Remember that you must deal only with situations that you can measure. What kinds of measurement can you devise?

VII

Idea of Extrapolation and Interpolation

1. Idea Bridge: "Thinking About Extrapolation and Interpolation--
Making Judgments on the Basis of the Data That We Have"
2. Laboratory Experiences:
 - a. Extrapolating and Interpolating from a Graph
 - b. Alternative Hypotheses: An Experience in Extrapolation
 - c. Looking for Patterns in Behavior
 - d. Extrapolation in Terms of a Problem: A Science Fiction Story

Thinking About Extrapolation and Interpolation: Making Judgments
on the Basis of the Data That We Have

"The only way we have of judging the future is by the past." "A leopard cannot change his spots." "As the twig is bent---." "History repeats itself." How many other proverbs can you think of that say the same thing? Long before the advent of modern science people were trying to look into the future to see what it was likely to bring, and the only way that they could do so was to study the past, project any trends that they found there into the future, and assume that these trends would continue.

One of the basic assumptions of science is the principle of consistency. A scientist assumes that the behavior of the universe is not capricious, but is describable in terms of consistent laws, such that when two sets of conditions are the same, the same consequences may be expected. Non-scientists, even uneducated people, assume the same thing. Why do we expect the sun to rise in the east each morning? Because it has always done so. Why do we expect a book to be where we left it (assuming that no one has moved it, and that it has not been moved by some force of nature)? Because all of our experience indicates that books do not move of themselves.

Why do we expect water to flow down hill, electric current to flow through lamps and make light, or through heating elements and give rise to heat, and other forms of energy to change form and do work? Because natural laws have described accurately the way that physical nature has behaved in the past, and by the principle of consistency we expect that they will continue to do so in the future. Even in the days when people believed in magic, they did not believe in an anarchic and capricious world. They believed in "laws of magic" which they held to be consistent, dependable, and subject to use by those who understood them.

If a scientist wishes to estimate what the population of the world will be in 2000, he studies the census figures taken at intervals during the present century, determines the rate of population growth at the present time, and projects this forward to the end of the century. This is called extrapolation. If a writer wishes to write a plausible science fiction story, he studies the results of scientific research up to the present time, considers what we may reasonably expect to be the results of research in fields where research is active, and then writes his story as though we were now in the future and these things had already taken place.

Not only science fiction writers, but scientists themselves do this. Thus there is serious consideration of the possibility of artificial hearts, replacement of whole organs from organ banks, manipulation of the heredity of man and other organisms, weather control, chemical control of human behavior, synthetic food, and simple forms of life produced in the laboratory. All of these are only extensions of research that is already well advanced. This also constitutes extrapolation. On the other hand, there is no serious talk of travel backward in time, because there is no basis for the possibility of this in any present-day research, or by the application of any principles that we now know. Here there is no basis for extrapolation.

Interpolation is related to extrapolation. It consists of "filling in the gaps" between data that we have, rather than projecting forward from data that we have. We have two temperatures taken successively at different times during an experiment when the temperature was increasing at a constant rate. We need to estimate what the temperature was at a point midway between these times. We arrive at an estimate by interpolation. We assume that the temperature likewise was at a point midway between. Here again we have made a judgment on the basis of the data that we have, assuming the operation of the principle of consistency.

The scientist's use of extrapolation and interpolation is nothing more than a formalization and extension of the common-sense practice of estimating the future on the basis of the past, making reasonable predictions on the basis of what is happening now, and filling in the gaps in what we know with reasonable approximations.

Extrapolating and Interpolating from a Graph

Introduction:

Constructing a graph that records quantitative data is of value because the graph makes it possible to visualize relationships, and makes it easy to extrapolate and interpolate from the data. Data can be collected in quantified form by weighing or measuring with simple equipment or equipment of varying degrees of complexity. The simplest way of collecting quantified data is by counting.

In the following laboratory experience, you will study a simple relationship through counting. This is a relationship that you look at every day, but probably have not thought of. Ordinarily you use a clock to tell time. In this case you will be using a clock to study the relationship of two constant rates of movement.

Materials and Equipment:

Clock having a round face with an hour hand and minute hand, and with spaces marked to indicate minutes.

Graph Paper

Pencil

Ruler

Procedure:

1. Carry out this experience without reference to "time of day." You are not concerned with "what time it is," but only with the action and relative positions of the two hands on the clock face.
2. Note that the clock face consists of a circle, marked off into 60 spaces of equal length, which for the purpose of this experience we will call "minute-spaces." Note also that there are two "hands;" the longer one is the "minute hand," and the shorter one is the "hour hand." These are fastened at the center with the outer ends left free. Each hand moves around the circle at a constant rate of speed, the minute hand moving faster than the hour hand. At regular intervals, they come to occupy identical positions horizontally, with the minute hand directly above the hour hand. How often do they do this? What relation does this have to marking the passage of time?
3. Start the experience at any point on the clock face at which the minute hand is exactly above the hour hand. Record this position in your notes.
4. Observe that as the minute hand moves beyond the hour hand, the number of minute-spaces between them increases.

5. Count the number of minute spaces between them at the following time intervals, figuring fractional spaces to the nearest full minute:
 - a. after 7 minutes
 - b. after 13 minutes
 - c. after 18 minutes
 - d. after 32 minutes
 - e. after 36 minutes
 - f. after 45 minutes
6. Record these data on a piece of graph paper with the horizontal axis representing number of minutes, and the vertical axis representing number of spaces:

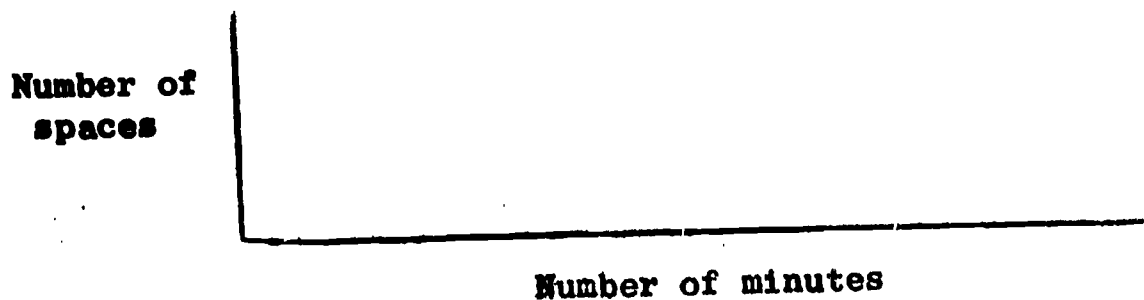

7. Draw a line connecting the positions on the graph. Describe the line. What are its characteristics? Why?
8. By extrapolation, place a dot at a point indicating the number of spaces by which the hands would be separated after 56 minutes. After 62 minutes.
9. By interpolation, place dots at points indicating the number of spaces by which the hands were separated after 27 minutes. After 41 minutes.
10. Can you, by extrapolation, indicate the number of spaces by which the hands would be separated after 75 minutes, 89 minutes, and 97 minutes, if it were not for the physical limitations of the clock face? Could a clock be made where this continued relationship would be possible? If so, how? What is the relationship which your graph is showing, and is there any reason why this relationship should necessarily be limited to the possibilities of any clock face or any other physical device?

Further Investigations:

Fasten a yard stick or meter stick in a horizontal position. Suspend a small weight from a string above it to make a pendulum. Start the pendulum swinging. Note and record on a graph the length of the swing. Let the vertical axis of the graph represent length of swing, and the horizontal axis represent time. Note and record at regular intervals as the pendulum "runs down." After several recordings, extrapolate the line on your graph to the point in time when the pendulum will cease to swing. After doing this, continue your observations and test the hypothesis based on your extrapolation.

Would it be possible, utilizing the same principle by which the kind of clock you have been using is constructed, to make a clock which would mark the passage of days, weeks, months, years, centuries? What difficulties would be encountered if one should attempt to make such a clock? To what would these difficulties be due? Could they be corrected? Partially? Wholly? If so, how? If not, why not? Has such a clock ever been made?

What difficulties have been encountered in the making of calendars? What has been the history of calendar making? What people have made calendars and in what periods of history? How have various attempts to make calendars differed from one another? To what extent have calendar inaccuracies been corrected? How has this been done? To what extent do inaccuracies still persist? Why? How are man's attempts to make calendars related to the process of extrapolation?

Alternative Hypotheses: An Experience in Extrapolation*

Introduction:

All prediction is extrapolation, whether it occurs in connection with using scientific data or in everyday living. Everyday living relies heavily on prediction. We assume that things and people will continue to behave as they have been behaving. When we say that a person is behaving "out of character" we mean that we would not have predicted this particular behavior on the basis of what we knew of him. His behavior is contrary to the extrapolation which we had made based on our previous experiences with him. If it were not for our assumption (prediction) that the people and things with which we deal would continue to behave "in character", our world would be a chaotic place in which no rules held true.

Likewise all extrapolation is prediction. Any hypothesis that we set up involves extrapolation. A hypothesis is a proposed tentative explanation (or solution, or conclusion). What we are saying is, "All of the data that we have can be explained in this way. If or when future data are discovered, they should likewise fit this explanation." We are extrapolating on the basis of the limited data that we have. We are predicting the nature of the additional data that we expect to find.

It is frequently possible or necessary to set forth several alternative hypotheses. This is particularly likely to be true when the data that we have are extremely limited. In this case we are making several alternative extrapolations (predictions). We continue to look for additional data, and when we find them we see which of the hypotheses they best fit. Sometimes they do not fit any of the hypotheses that we have set forth. In such cases we have to modify one or more of our hypotheses, or even make one or more new ones. We must continue our search for additional data, and for an adequate explanation of them, until either (1) we are able to explain all of the data with a single hypothesis and rule out all others, or (2) we find that we cannot obtain a sufficient number of data to narrow the field to a single hypothesis, in which case we have to leave two or more hypotheses at the level of "possibly true."

Materials and Equipment:

Pencil and paper

Blackboard and chalk

Inch rule or millimeter rule

Procedure:

1. Place four dots on a piece of blank paper, each one equidistant from two of the others, in any arrangement that you wish.

*This laboratory experience is based in part on "A Demonstration of the Use of Alternative Hypotheses," by Charles H. Coleman, in School Science and Mathematics 66:81-85, January, 1966.

2. See how many different arrangements you can think of in which this is true. Compare notes with your classmates, or place all arrangements on the blackboard. Be sure that you have exhausted all possibilities of arrangement. How many arrangements are possible?
3. Now, for each arrangement, see how many figures you can draw so that your four dots constitute points on its perimeter (square, rectangle, circle, triangle, figure X, figure 8, and so forth). Again compare notes with your classmates and/or put all figures on the blackboard. How many figures are you able to make?

Your four dots constitute four bits of data in the solution of a problem, or a series of related problems. Each figure constitutes a hypothesis, which sets forth a possible solution for the problem. A hypothesis is a projection into which data that we do not now have, but may ultimately discover, will fit. If the future data fit the hypothesis, then the hypothesis is correct. In the case of each of these figures, it is assumed that all future dots will fit into the perimeter of the figure, supplement the four that you already have, and serve to further outline the figure.

When you postulate (predict) the existence of additional dots beyond your original four, you are extrapolating upon the basis of the data that you have. In the case of each figure, a limited number of additional dots will serve to define the figure. They will outline it to a sufficient extent that you can be certain of its shape; that it is as you have drawn it and not some other shape.

4. In the case of each figure, extrapolate a sufficient number of additional dots to define the figure. Do not put in any dots that are not necessary to define it. How many additional dots are necessary in each case? Is the number the same in all cases? Remember that there must be enough dots so that some of those shown cannot lie in the perimeter of any of the figures, other than the one in which you have included them. Are there any dots beyond the original four that can lie in the perimeters of more than one of the figures? If so, you may use them, but you must use others in addition.

If, through research, you were to discover that only those additional dots defining one of the figures actually existed, what would this do to the hypothesis represented by that figure? What would it do to the hypotheses represented by the other figures? In this case, how would the procedure which you followed in your hypothesis making and your later research be comparable to that of a scientist solving a problem?

How was your procedure in postulating additional dots in the case of each figure an example of interpolation as well as extrapolation? How is interpolation related to extrapolation? To what extent do they constitute specialized aspects of the same procedure?

Further Considerations:

To what extent do our actions in daily thinking and living constitute extrapolation? Think of as many examples as you can. To what extent do they constitute interpolation? Think of as many examples as you can. To what extent do natural laws constitute extrapolations?

Looking for Patterns in Behavior

Introduction:

We depend on patterns in nature. We order our lives by them. Try to imagine what the world would be like without such patterns. We know that they exist and that we can depend on them. This knowledge makes it possible for us to face the future with confidence, based on our expectation that past experience furnishes us a good indication of what we may expect.

We set up hypotheses based on our past experience and make these the basis for our actions. We do not call these projections hypotheses, however. Usually we do not call them anything or even realize what we are doing when we make them. We simply act on them without verbalizing them or even thinking about them. This is practical, everyday extrapolation.

When we say, "I think I'll take this letter down to the principal's office before the noon rush starts," or "I think I'd better get started home before the 5 o'clock traffic begins," we are extrapolating on the basis of our past experience of threading our way through a mass of students in the corridor just before lunch, or our experience with the traffic jam that regularly occurs at the end of the working day. We are acting on the hypotheses that we have made, that people and cars will behave today in the same way as they have in days past when we have been caught in such rushes.

In the laboratory experience which is outlined here, you may or may not discover a pattern. Do not feel that the experience is a failure if no pattern appears. The important thing is that you will be carrying out a procedure like that by which scientists have discovered and described patterns in the natural world. Perhaps if no pattern appears in this case, you may then be able to think up some other situation in which you can search for a pattern.

Materials and Equipment:

Graph paper

Pencil

Ruler

Procedure:

This laboratory experience can best be carried out as a class project, with different students being assigned the job of collecting data each day during the three week period while the study is going on. The graphs on which the data are recorded can be posted in the classroom where the entire class can watch the progress of the study.

1. Select a point in the busiest corridor in the school. Count the number of persons who pass this point at a series of designated times during the school day (e.g., from ten minutes before the end of each class period until the end of the period). If there

are too many to count accurately during a particular rush time, such as just before noon, make the best estimate you can.

2. Do this at the same times each day, Monday through Friday, during three successive weeks.
3. Record the data for each week on a graph:

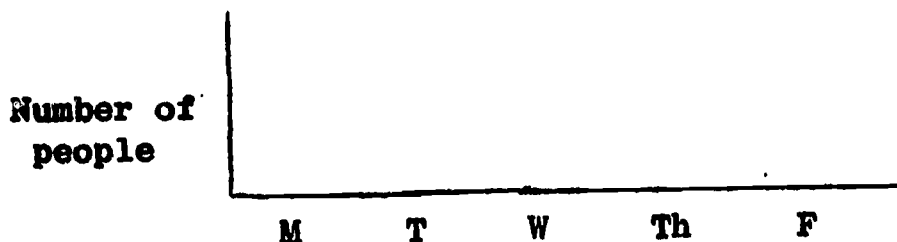

Is there a pattern? If so, why do you think it exists? If there is no pattern, why do you think there is none? Set up one or more hypotheses to explain what you have found. Through class discussion select what you believe to be the best hypothesis.

4. Test your hypothesis by continuing your observations on the same basis for one or two additional weeks. If you consider it desirable to collect data concerning environmental conditions, or anything that you think might have been responsible for either the presence or absence of a pattern in your findings, do so.
5. Do your further studies support or refute your hypothesis? Test it further if you wish to do so.
6. Draw a conclusion, or decide that you cannot do so because of lack of sufficient data, lack of sufficient time to test further, or any other reason.

At what point did you begin to extrapolate? Of what did your extrapolation consist? Compare your procedure to that of a scientist studying a pattern in nature. How do natural laws relate to patterns in nature? How are natural laws related to hypotheses?

Further Investigations:

Set up a study of the movement of automobiles and other motor vehicles past a particular point on a street or highway. Use the same type of procedure that has been suggested in looking for a pattern in the movement of persons in a school corridor. Here again set up and test hypotheses, and try to draw conclusions.

What other possibilities can you think of for the existence of patterns that might be interesting to study?

Extrapolation in Terms of a Problem: A Science Fiction Story

Introduction:

Some science fiction is the result of imagination, based on extrapolation from known facts. The nuclear bomb, space travel, and other recent developments now becoming commonplace, were predicted in science fiction prior to their development. Controlled heredity, replacement of human organs from organ banks or by artificial devices, chemical regulation of human behavior, and the synthesis of simple forms of life in the laboratory, are similarly being predicted at the present time.

The following experience constitutes laboratory only in the sense that it deals with a problem. A possible future situation is presented which would lead to a many-sided problem for individuals and society. You are invited to approach this situation through thinking and discussion. This invitation is based on two quotations:

- 1) a fictional story outline that was written about 1950, and was used as a basis for class discussion at that time.
- 2) a newspaper article that was written concerning the same topic in 1965.

We may very well face this situation in the not too distant future.

The Story:

In the century that has passed since the middle 1800's, medical science has made tremendous advances. Pasteur's germ theory of disease, the development of antiseptic techniques in hospitals, knowledge of the microbial world and the development of vaccines, an understanding of human physiology, the development of antibiotics, and other discoveries and developments, have greatly lengthened the human life span. Infant mortality in Western countries has been reduced almost to the vanishing point. Some infectious diseases have all but disappeared. More people are living into old age, even though the maximum age has not been increased.

The role of medical science has been to discover or develop a series of "bridges" which enable our bodies to cross over the danger spots in our lives. Without these artificial aids we would probably die the early deaths that our ancestors did. Medical scientists through research are constantly expanding the kinds and quality of available "bridges", and the end is certainly not yet in sight.

A woman born in the early 1930's would have been only a small child at the time when sulpha drugs were first used to combat the pneumococci of pneumonia in 1937. Let us follow this woman through her life.

She possessed a respiratory weakness which, in conjunction with the pneumococci present in her environment, and probably other environmental factors, caused her to develop pneumonia in the winter of 1937. She had a severe case. Pneumonia at that time was frequently fatal. She would have died

if it had not been that the family physician was a progressive practitioner who kept up with the latest developments in his field. He had read of the new sulpha treatment for pneumonia in a medical journal. Since he was a friend of the family, he obtained some sulphanilamide, and got her parents' consent to try it. The effects appeared almost miraculous, as such cases did in those early days of modern chemotherapy. The child's fever disappeared in a matter of hours, and she got well quickly. Medical science had furnished her with a "bridge" to cross a danger spot in her life.

The little girl grew up. She was not a strong child, but with good food, good home environment, and generally good care on the part of her parents, she escaped further serious illness during childhood. She went away to college in the late 1940's. On the occasion of her first Christmas vacation at home, she stayed out too late, lost too much sleep, lowered her general resistance to disease, and finally, after a New Year's Eve party, she took a deep cold which allowed the ever-present pneumococci to take hold again. She developed pneumonia a second time. Once more without help she would have died. This time, however, there were not only sulpha drugs but also penicillin and other antibiotics which were effective for pneumonia. Her recovery was quick and complete. She returned to school on time. Once again she had crossed a danger spot in her life with the aid of a "bridge" which medical science was able to provide.

After this she was aware of her weakness and was more careful. She knew that there were certain risks that she must not take. She graduated from college, married in the early 1950's, and had three children. She and her husband were reasonably prosperous, so that she was able to maintain a good environment for herself and her family and to have adequate medical care when she needed it. As she grew older she became stronger, because middle-aged people are generally more resistant to infectious diseases than children and adolescents. She had no more serious illnesses for a long time.

Finally, in her middle fifties, she developed a breast cancer. A hundred years earlier this would have been fatal. Actually, at this time it was not too serious. The condition was diagnosed in its early stages. Surgery, with X-ray treatments following the operation, successfully destroyed the cancer. She had managed to cross one more danger spot in her life with the aid of medical "bridges."

During the following decades there was no further serious trouble. Her respiratory weakness was now far in the past, and the cancer weakness was present only for a brief period in her fifties. Aside from colds and an occasional virus infection, she was a relatively healthy old lady. Her son and her daughters had been married long since, and she now had grown grandchildren. Her children were becoming elderly people.

At the age of 92, in the decade of the 2020's, her daughter's oldest granddaughter was to be married. It was a great affair. The family arranged for the old lady to travel by plane from Chicago, where the family lived, to California to attend it. The excitement was too much for her old circulatory system. She suffered a heart attack and died of a coronary thrombosis, a blockage of one of the larger blood vessels that carry food and oxygen to the heart muscle. At last she had come to the point of expression in her life of a weakness that medical science had found no means of circumventing. No "bridge" was available.

Medical science, however, is constantly learning more and more about the body and how it works and about the chemical relationships on which its health depends. In this way, more and more "bridges" are being discovered or developed. The next century will see this carried even farther. So by imagining a century into the future we can add a little more to our story.

If the old lady had been born a century later, in the decade of the 2030's, her life history would have ended quite differently. In 2029, just a hundred years after Fleming's discovery of penicillin, a biochemist working for the Rockefeller Foundation discovered a synthetic chemical compound of relatively simple structure. When it was taken into the body in small quantities regularly, it prevented the formation of cholesterol. This is the substance in the blood stream which research, nearly a century earlier, had found to be responsible for the clogging of the arteries with advancing age.

With the arteries remaining clean, flexible, and "young", and the circulation to the brain, kidneys, and other vital organs not becoming impaired, the general process of aging which appears to depend partly on the progressive deterioration of the circulatory system, was greatly slowed.

Thus another "bridge" was added to man's growing collection, and the average human life was greatly lengthened. Just as the average life expectancy of a child at birth advanced from about 54 years in the 1920's to about 69 years in the 1950's, following the development of antibiotics and other radically new types of therapy, so now it advanced still farther. Furthermore, it was not simply the over-all life span that was lengthened. The onset of old age was greatly slowed. A man or woman of 60 looked and felt no older than a person of 45 had done a century earlier. At 100 years a person seemed no older than we normally think of people being in their 70's. Old age came, on, but only with the aging of other body systems, and at a much slower pace. Finally, death from some type of physical and physiological breakdown occurred normally at somewhere between 100 and 125 years.

By the 2040's this age-delaying drug, which had been found to be completely harmless and without other physiological effects, had come to be as commonly accepted as the use of iodized salt to prevent the development of goitre, and Vitamin D enrichment of milk to prevent rickets. The new drug was mixed with seasoning, added to bread, and placed in city water supplies. Everyone used it, just as a matter of course. A few religious groups objected to it at first. They said that it was sinful to try to extend life beyond "three score and ten," but this objection was short-lived. No one really wanted to grow old if they could keep from doing so.

Of course the maximum effectiveness of the drug was in the case of children who began to take it in their early years. It only served to delay the artery-clogging process. It did not in any sense turn back the clock. If our old lady who had died of circulatory breakdown at the age of 92 in the 2020's, had been born in the 2030's, she would have started taking the drug when she was about five years old. If she had done this she would have lived to the ripe old age of 120, and would have died in the 2150's from a breakdown of digestive function. This particular weakness was one which only became known to medical science when people generally began to live to ages beyond 100 years. Even the advanced medical science of the middle twenty-second century had not yet found a way to circumvent it.

The Newspaper Article:

Reaction Mixed to Proposal to Prolong Life of Humans

NEW YORK (AP)---A variety of reactions ranging from "great", to "contrary to nature", and "highly unlikely" came today from both young and old after a pathologist suggested that science might someday delay the aging process.

Dr. Robert R. Kohn, a pathologist at Western Reserve University in Cleveland, says "There's no theoretical reason why we should not be able to keep people as they are at age 20 to 30 for another 40 years, assuming society would want it." He offered the theory that aging is a normal disease and conceivably susceptible to being inhibited by chemical or other means.

Some indicated they would want it. Baseball catcher Joe Torre, 24, of the Milwaukee Braves, said, "It would be great." Harold Lloyd, a comedian who starred in the silent picture era, remarked, "I'm all for it."

Others indicated they would prefer to let nature take its own course. Marilyn Wahl, 21 a Los Angeles airline stewardess, said: "I don't think I'd like it. There are rewards in growing older and maturing. There are pros and cons--growing old with your children and enjoying some of the things they do. But there is something wonderful about maturing. If it were twice as long, the 20 to 30 age bracket would not be quite so enjoyable."

A Dallas lawyer who is approaching 80 said, "There is no need to speculate about remaining 20 to 30. That is contrary to nature, the Bible and the Lord's decree."

Ann Bittner, 47, a Chicago television assembly line supervisor, and Dr. Bonnie Strickland 26, dean of women at Emory University, reacted differently. "I think people from 20 to 30 are dying faster than older folks or they soon will be," said Mrs. Bittner. "The reason is they live too fast. Bad diets and carelessness with their health in general puts them in bad shape. Why make more people get into bad shape by keeping them at a careless age?"

Dr. Strickland, one of the youngest women deans in the country, said prolonging life between the ages of 20 and 30 "would be wonderful--if you were able to continually mature. Youth without wisdom and knowledge would have no advantage," she added.

Dr. John Knowles, 39, general director and physician at the Massachusetts General Hospital and lecturer at the Harvard Medical School, opined: "The process of aging and death is inexorable and inevitable."

Bill Ingram, 21, a Dallas college student, said he would like to stay 20 forever, but "some people can't cope with life and probably prefer death--look at the suicides." Ingram said he agreed with a statement by Dr. Bernice L. Neugarten, of the University of Chicago, who said: "The assumption is unproven that people would like to live longer than they now do--or that they would be better off if they did."

Dr. Neugarten and Kohn made their comments Wednesday in Washington at the Conference on Research Progress and Trends in Aging, sponsored by the National Institute of Health.

Kohn defined aging as "a normal biological process with onset sometime around maturity." He suggested it's primarily due to progressive changes in "collagen," a chemical occurring in the connective tissue outside the body's cells. Kohn said studies of a muscle disease in animals indirectly suggest the possibility of using a chemical called "beta aminonitrile" to slow down collagen changes, and possibly inhibit aging. He suggested the chemical for trial in animals.

Dr. F. Marott Sinex, a Boston University biochemist, also speaking at the Washington conference, forecast the secret of aging eventually will be found. "But," said Sinex, "even with prolonged youth, general wear and tear would still exact its toll." "There will always be a mortality force," he said.

Discussion:

What are the problems that would be posed by greatly lengthening human life? How do you think society might move to solve these problems? How would our world be different if human life were greatly prolonged? Do you think it would be a better world, or one less good? How do you, personally, feel about greatly lengthening human life?

Do you think that there is much likelihood that science will be able to greatly lengthen human life? If so, why? If not, why not? What developments other than the one that formed the basis of the story do you think might contribute to greatly lengthening human life? Why?

How does the development referred to in the story and the newspaper article constitute extrapolation? Extrapolation from what?

What other science fiction stories can you think of that might be written, based on scientific developments that we now know about? Would you like to try to write one?

VIII

Idea of Cycles and Cyclic Change

A. Idea-Bridge: "Thinking About Events That Occur in Cycles"

B. Laboratory Experiences:

1. "An Animal Life Cycle: The Fruit Fly, Drosophila"
2. "Simple Plant Cycles: Common Molds and Bacteria"
3. "The Water Cycle"
4. "Days and Nights, Moons and Years"

Thinking About Events That Occur In Cycles

In the natural world we can recognize some change which is apparently patternless, and various kinds of patterned change. One form of patterned change is directional, another is cyclic. Cyclic change appears to be directional if it is looked at on a short-term basis. It is possible that all directional change would be cyclic if it were viewed on a sufficiently long-term basis. The elements of both of these forms of change might appear to be patternless if the term of observation were short enough.

If we look at the natural phenomena that occur around us, we find that many of them belong to related sequences of events that take place in cycles. This is true of both living and non-living nature. Thus we have life cycles of organisms, cycles of use of chemical elements such as carbon and nitrogen, the cycle of erosion and deposition on the earth's surface, the cycle of rock formation involving igneous, sedimentary, and metamorphic rocks, the water cycle, and the cycles of movement of bodies in the universe on which most of our measurement of the passage of time is based. This by no means exhausts the list. We can examine certain aspects of some of these cycles by observing them and thinking about them.

An Animal Life Cycle: The Fruit Fly, Drosophila

Introduction:

All living things, plants and animals, go through a cycle of development from minute reproductive bodies to maturity, when they give rise to new reproductive bodies. The stages of the human life cycle are well known: pre-natal life, birth, infancy, childhood, youth, maturity, reproduction. Strictly speaking, although old age is a part of the life of each person who lives out a normal life span, it is not a part of the cycle.

In other animals there is a comparable cycle. The life cycles of some insects are well known and easy to study. It is easy to read about the life cycles of common insects in books, and it is not difficult to observe some of them in the laboratory. Studying them in the laboratory is interesting, not only from the standpoint of learning about them first-hand, but also because of the questions that the observations raise in our mind.

Stages in the Fruit Fly Life Cycle:

In general, there are two types of insect life cycles: (1) those with incomplete metamorphosis, and (2) those with complete metamorphosis. Metamorphosis means change, and the words "complete" and "incomplete" refer to the kind and extent of the changes that occur. The life cycle of a grasshopper proceeds through a series of progressive changes comparable roughly to those of a human, with growth in size, but without radical alterations of body form after hatching from the egg. This type of life cycle is an example of incomplete metamorphosis. The life cycle of a fly, by way of contrast, includes four distinctly different stages: egg, larva, pupa, and adult. This constitutes complete metamorphosis. The fruit fly, Drosophila melanogaster, which is used for experimental work in the study of heredity, furnishes a convenient laboratory example of this type of life cycle.

The eggs of the fruit fly are small. They are generally deposited on the surface of the food material. They are barely visible with the unaided eye. At room temperature they hatch into larvae in about 24 hours. The larvae are minute maggots that can be observed eating in the food material. They increase in size and change into seed-like pupae, which are attached to something and are inactive. When the larvae are ready to pupate, they usually climb up on the sides of the culture bottle or on the piece of paper towel which has been placed in it. The adult flies emerge from the pupal cases. At first they are very weak and will die if they become stuck in the food material. As they strengthen, their wings expand and they are able to fly.

Male Drosophila can be distinguished from females by the presence of a broad black tip on the abdomen. Both sexes have black bands across the abdomen, but the female lacks the broad black tip.

Growing the Fruit Flies:

Drosophila live in nature around decaying fruit. They eat the yeasts that grow on the fruit, not the fruit itself. You may observe them around rotting apples, bananas, or other fruit, or around garbage cans containing any decaying materials on which yeasts can grow.

If you have never seen yeast cells you should look at them under the microscope in connection with your fruit fly experience. When you are preparing your culture bottles for the flies, place a very small piece of the yeast cake on a glass slide, put a drop of water on it, mix it thoroughly with the water, cover with a cover slip, and observe with both low and high power of the microscope. What do yeast cells look like? How do they reproduce? What do they live on? What substance is a by-product of their life processes?

There are several species of *Drosophila* that occur wild in nature. The species which is commonly used for experimentation is *Drosophila melanogaster* (literally, the "black-bellied *Drosophila*", so named from the black-tipped abdomen of the male). They can be raised in the laboratory in any kind of bottle or glass container that has an opening small enough to be closed with a plug of cotton. Why a cotton plug rather than a rubber stopper or other solid top?

Their food in the laboratory can consist of any kind of medium on which yeasts will grow. The standard culture medium is made up in agar. This is a gelatinous material which can be prepared ahead of time with standard amounts of the necessary components, and sterilized to eliminate molds and other harmful organisms. It has a relatively hard surface which lessens the danger of freshly emerged adult flies or anaesthetized flies getting stuck in it. It may be purchased already made up from biological supply houses, or it may be prepared according to recipe by the teacher. (See attached directions for preparation.)

Fruit flies can be grown quite easily, however, on mashed banana, seeded with yeast. The banana does not need to be cooked or sterilized. Some cultures grown in this way may be lost from mold infestation, but in such case the molds themselves have a life cycle which is interesting to observe. Through what stages does a mold develop? How does it reproduce?

When growing fruit flies on banana there is greater danger of the original pair of flies and the freshly emerged adults becoming entangled in the surface of the culture medium. Most of this risk can be eliminated by placing a small cone made of paper toweling in the bottle, and exercising care in depositing the original pair in this cone while they are anaesthetized. In a way, growing the flies on a natural medium is more interesting because it is less standardized and presents a greater challenge.

Materials and Equipment:

Compound microscope

Hand lens

Slides

Medicine dropper

Stapler

Pint milk bottles

Paper towels

Cotton

Laboratory forceps (4-6 inches long)

Ether

Ripe bananas

Yeast cake (Fleischman's or Red Star)

Fruit flies (wild or cultured)

Procedure for Preparation of Culture Bottle:

1. Thoroughly wash the milk bottle in which you plan to grow the flies.
2. Put mashed banana in the bottle to a depth of about one inch.
3. Break up a piece of the yeast cake about the size of a pea in a small amount of water, to make a milk-like suspension. Fill a medicine dropper about one-fourth full of the suspension, and spread it over the surface of the mashed banana.
4. Fold a piece of paper toweling two to three inches square into the form of a cone.
5. Staple the side of the cone where it has been folded with a stapler, so that it will retain its shape.
6. Using a pair of forceps, place the cone in the bottle, point downward.
7. Press the point of the cone into the mashed banana to the extent necessary for it to remain erect.

Procedure for Handling the Fruit Flies:

1. If you wish to catch wild fruit flies, you may do so during the warm season by placing a milk bottle containing ripe banana near decaying fruit outdoors. When your milk bottle trap has a number of flies in it, close it quickly with a cotton plug. Remove the freshly caught flies as directed in (3) below. Anaesthetize them and distinguish between males and females. Place one or more males and the same number of females in a fresh culture bottle prepared as directed above. Plug the bottle with cotton and observe the life history stages as they appear.
2. You may obtain laboratory cultures of fruit flies from any biological supply company at a minimal cost. Since these are mainly ordered for genetical experimentation, most of them are strains carrying special hereditary characteristics. Therefore you should specify "wild type" when you order. When you receive the culture, remove the flies as directed in (3) below, anaesthetize them, distinguish between males and females, and place one or more males and the same number of females in a fresh culture bottle prepared as directed above. Plug the culture bottle with cotton and observe the life history stages as they appear.
3. To remove the flies from either the bottle in which you trapped them, or the bottle in which you received them, proceed as follows:
 - a. Take a clean, empty bottle with an opening the same size as that of the bottle containing the flies. Prepare two cotton plugs for it but do not insert either of them.
 - b. Tap the bottom of the bottle containing the flies gently against the palm of your hand to shake them back from the top.
 - c. Quickly remove the cotton plug from the bottle containing the flies, and place the mouth of the clean, empty bottle tightly against the mouth of the bottle containing the flies.
 - d. Hold the two bottles so that the bottom of the clean, empty bottle is pointed upward and toward the light.
 - e. The flies crawl or fly toward the light. When all of them have gone into the clean bottle, close it with one of the cotton plugs, while it is still held mouth downward.
 - f. If you are using laboratory cultured flies, replace the cotton plug in the culture bottle. You may wish to put part of your flies back into it.
4. To anaesthetize the flies:
 - a. Open a bottle of ether. Hold the bottom end of the extra cotton plug against the opening, and tip the ether bottle so that some of the ether is soaked up by the cotton plug. Keep away from fire! Ether is highly flammable.

- b. Turn the bottle containing the flies bottom upward toward the light. Allow all of the flies to crawl or fly upward toward the bottom of the bottle.'
 - c. Quickly remove the cotton plug from the bottle containing the flies, and replace it with the etherized plug.
 - d. Turn the bottle top end upward. Watch the flies closely. It is easy to kill them with ether. You only wish to render them inactive. How do they respond to the ether? Do they all "go to sleep" at the same time? Why or why not? As soon as the last fly has become inactive, remove the etherized plug. Pour the etherized flies out onto a piece of white paper.
 - e. Examine the flies with a hand lens. Use the forceps gently to move them around on the paper as you examine them. Do not touch them with your fingers. They are easily injured. Note males and females.
5. To set up a breeding culture:
- a. As quickly as you can, select one or more pairs of flies.
 - b. Pick each fly up with the forceps, holding the fly by one wing.
 - c. Place each fly carefully in the cone of paper toweling in the culture bottle which you prepared earlier. Do not drop the flies on the surface of the mashed banana.
 - d. When you have dropped all of the selected flies into the cone, close the culture bottle with a cotton plug.
 - e. If you wish to replace the remaining flies in the original culture bottle you may do so. In this way if your new bottle is not a success, your original stock will still be available. Handle each fly in the manner directed in (b) above, and place it carefully in the bottle.
 - f. Watch the flies in the new culture bottle emerge from anaesthesia. Do they all so so at the same time? Compare with the manner in which they went into anaesthesia. Did all of your flies "come out of it"? If they did the then you know that you over-etherized them. You will know better next time! Sometimes practice is necessary. Is there anything else that you would do differently if you were to repeat the experience?
6. Record the date when you set up the culture. Observe the development of the culture over a period of two to three weeks. Are you able to see the eggs on the surface of the food material? How long before the larvae appear? What kind of activity do they show? Are you able to see them eating? Observe their growth in size. How large do they get? How long do they remain in the larval stage?

How long before the first pupae appear? Where are they formed? Observe as much as you can of the process of pupation. How does it appear to take place? If the larvae or pupae are observed on the sides of the bottle, examine them with a hand lens. As the pupae become older, how much structure can you see inside them? Correlate what you can see with structures in adult flies.

How long before the first adults emerge? Observe the freshly emerged flies. Why are they weak? Watch them gain strength. How do their wings strengthen? How long before they can fly?

Your new generation of flies are now adult, and are ready to repeat the cycle. Set up a new culture and watch them go through the cycle again if you have time. Do the life history stages occupy the same length of time that they did before? If they are not quite the same, why do you think this might be?

What have you been able to observe concerning the effect of various environmental factors on the flies? We have called your attention to their reaction to light. What about temperature? Does temperature have anything to do with how long it takes them to go through their life history stages? Your flies developed at room temperature. If you go through the cycle a second time, try experimental cultures at cooler and warmer temperatures. Does constancy of temperature through the 24-hour period affect the development in any way?

Further Considerations:

Fruit flies live on yeasts which will grow on anything containing sugar. Try growing them on other kinds of fruit: apples, pears, peaches, grapes, et cetera. Try using the fruit without mashing it. What do you find to be the best kind of fruit, and the best method? Get a box of sweetened gelatin dessert at the grocery store (Jello or similar product). Follow the directions on the box in preparing it. Pour it while hot into a clean culture bottle. Seed it with yeast. Try growing flies on this material. Does it work? Try enriching the gelatin dessert with sugar when you prepare it. Try different concentrations of sugar. What is the most effective concentration?

What do you think is the best method of growing fruit flies, using readily available materials?

What kinds of phenomena in living organisms are cyclic? Think of as many examples as you can. What about the process of cell division (mitosis)? Read about this process. Study diagrams of the stages in it. See a motion picture devoted to it if you can. Determine to what extent it is a continuous, cyclic process? To what extent is it a universal phenomenon in living organisms?

*Formulae for Making Culture Media for Growing Fruit Flies

Note: The materials for making up these media can be purchased in part at any grocery store. Those which cannot be obtained locally can be ordered from General Biological Supply House, Inc., 8200 South Hoyne Avenue, Chicago 20, Illinois, or any other biological supply company.

Banana Agar

575 cc water

20 gr. agar-agar

35 gr. brewer's yeast

125 cc white corn syrup

225 cc crushed ripe banana

$\frac{1}{2}$ gr. mold inhibitor

Add agar-agar to the water and bring it to a boil. Stir in the mashed banana and mix thoroughly. Add the yeast, syrup, and mold inhibitor, and boil for ten minutes. Pour into culture bottles, and add strips of paper toweling which has been dipped in a solution of 1.5 gr. mold inhibitor dissolved in 5 cc of 85% alcohol.

Oatmeal

45 gr. yellow corn meal

45 gr. oatmeal (old-fashioned Quaker Oats, not the quick cooking kind)

4 gr. brewer's yeast

1 gr. mold inhibitor

Slowly add 25 cc molasses and 600 cc water as the medium is heated over a low flame. Do not boil. Stir constantly. Pour into culture bottles when the mixture is near the boiling point. Add a strip of paper toweling to each bottle.

* Taken from Turtox Service Leaflet No. 15, General Biological Supply House, Inc., Chicago, Illinois.

Simple Plant Cycles: Common Molds and Bacteria

Introduction:

Simple plants, like complex plants and animals, go through cycles of development from minute reproductive bodies, through a period of vegetative growth, to the formation again of reproductive bodies like those that gave rise to them. Many of the molds furnish excellent examples of such simple life cycles.

Although common molds may be obtained in pure culture from biological supply houses, and may be grown in the laboratory under controlled conditions, they can also be captured "in the wild" and grown on common, easily obtainable materials. It is interesting to catch them, and to observe the cyclic changes through which they pass.

Bacteria do not generally pass through true life cycles, at least not involving easily observable changes in physical form. They are usually captured in this experience along with molds, however, and their growth and propagation in the laboratory is interesting and can be seen along with that of molds.

Materials and Equipment:

Compound microscope

Glass slides

Cover slips

Medicine droppers

Hand lens

Dissecting needle

Forceps (four to six inches long)

Bunsen burner or other open flame

A source of heat for boiling water

A small cooking vessel

Petri dishes or other shallow dishes that can be covered

Potatoes

Procedure:

1. Cut a raw potato into slices three-eighths inch thick; leave the skin on.
2. Place the slices in water in a cooking vessel over a source of heat. Bring the water to a boil, but do not continue to boil the slices, and do not allow them to stand in the water. They will become soft and break if overcooked.
3. Remove the slices and place each of them in a petri dish or other small, shallow dish which can be covered. These dishes need not have been sterilized, but they should have been washed clean and kept covered after being washed.
4. Cover the dishes containing the potato slices, and allow them to cool to room temperature.
5. Uncover them long enough to "inoculate" them. Do this in as many different ways as you can devise (e.g., cough on one, put dust from the table top on one, dust from the floor on one, touch one with your finger, et cetera).
6. Cover them again; put them in a warm place. Look at them once a day. When you do so, uncover them only long enough to observe them carefully; then cover them again.

Each slice of potato almost certainly will develop colonies of micro-organisms: bacteria and molds. If you wish, you may leave one uninoculated. This will show you whether or not molds or bacteria will be picked up just by exposure to air for the brief period while the dish is open.

Colonies of bacteria will appear as white or yellow spots. Sometimes the surface of the bacterial colonies may differ in appearance in ways other than color. How many different kinds of bacterial colonies can you distinguish? Mold colonies are generally black, blue, green, yellow or brown. How many different kinds of molds can you distinguish?

Single cells of bacteria and the spores (reproductive bodies) of molds are able to resist drying, and are carried by air currents in the same way as dust particles. When a single bacterial cell or mold spore alights on the surface of a medium on which it can grow, it gives rise to a colony. The colonies of each species of bacteria or mold possess different and distinguishable characteristics.

7. With a dissecting needle, tease out a small fragment of each different kind of bacterial colony. Put it in a drop of water, spread it out in the water as much as possible, cover it with a cover slip and observe it with high power of the microscope. Can you distinguish the individual bacterial cells? Are they single or attached to one another (pairs, bunches like grapes, long hair-like chains)? Are they motile or non-motile? Do the different kinds of colonies show distinguishably different kinds of cells?

There are three different body types of bacteria: cocci, which are round, bacilli, which are rods, and spirilla, which are spirals. Cocci are generally non-motile. They may form pairs (diplococci), chains (streptococci), or bunches (staphylococci). Bacilli may be motile or non-motile. Colonies of bacilli look like hairs. The spirilla do not form colonies. They are generally motile.

8. Examine fragments of each kind of mold colony in a drop of water under the microscope. Low power is generally satisfactory for looking at molds. They consist of vegetative filaments which give rise to spore-bearing, knobby ends which are called sporangia when mature. Mash a sporangium by pressing on the cover glass to release the spores. See if you can observe filaments, sporangia, and spores.
9. Prepare fresh slices of cooked potato in clean, covered dishes. Inoculate some of them with material from bacterial colonies which you think would be interesting to propagate. Proceed as follows:
 - a. Sterilize the end of a dissecting needle by holding it in the flame of a Bunsen burner or other open flame.
 - b. Allow it to cool.
 - c. Insert it into the surface of the bacterial colony, and then into the surface of the potato slice. Replace the cover of the dish immediately.
 - d. Put the dish in a warm place and examine it each day as before. Does the same kind of bacterial colony develop at the point where you inoculated it? Are there other kinds of colonies? If so, how do you account for their being there?
10. Inoculate other freshly cooked potato slices with material from ripe sporangia of mold colonies which you think would be interesting to propagate. Proceed as you did with the bacterial inoculation, but use forceps instead of a dissecting needle. Sterilize the ends of the forceps before using them to transfer the mold material. Does the same kind of mold colony develop at the point where you inoculated it? Are there other colonies? Other kinds of colonies? If so, how do you think they got there?

You have now followed through the process of growth and propagation for two kinds of simple plants. Of these, the molds have a true life cycle involving (a) vegetative growth, and (b) sporangia containing spores which are reproductive bodies. The bacteria generally propagate without special reproductive bodies. To what extent are the growth and reproductive phenomena which you have observed comparable to the life cycle of a higher plant or animal?

Further Considerations:

Study molds growing on cheese, bread, and anywhere else that you can find them. Much modern commercially baked bread contains mold inhibitor. Therefore it keeps better, and is less likely to become mold infected. Nevertheless it is interesting to try to grow molds on bread. Try growing molds on bread by using the following technique:

1. Place a drinking glass in a saucer. Fill the glass about half full of water, and fill the saucer with water around the glass.
2. Inoculate a slice of bread with mold spores from an active colony which has been growing on a potato slice.
3. Place the slice of bread on top of the drinking glass.
4. Cover the whole assembly with a battery jar to form a moist chamber. Put it in a warm place and observe it daily.
5. Does a mold colony develop? Is there any difference in the growth of molds on different kinds of bread? How about home made bread?

Try growing molds under different environmental conditions. Is there a relationship to light? To temperature? To relative humidity? To moisture content of the medium on which the mold is growing?

What kinds of phenomena in living organisms are cyclic? Think of as many examples as you can. What about the process of cell division (mitosis)? Read about mitosis in biology textbooks, study diagrams of the stages in it, see a motion picture devoted to it if possible. Determine to what extent it is a universal phenomenon in living matter.

The Water Cycle

Introduction:

Water vapor from the surface of a body of water, or from wet soil, or from the leaves of green plants, is absorbed into the air and ultimately returns to the earth in the form of precipitation (rain, snow, sleet, hail). This is the water cycle. It is really not this simple, however. Water that falls on the earth's surface may be diverted from the cycle and stored for longer or shorter periods as ground water or as surface water in lakes, streams, et cetera. Some ground water is "fossil water" that has been stored for millions of years. If people in an area are using ground water faster than it can be replaced from natural precipitation, they are depleting underground supplies and are facing a water famine sometime in the future. In what parts of the United States is this now true?

Water may be diverted temporarily by passing through the bodies of animals (including humans). Some is chemically combined and so is lost to the cycle temporarily. Water is used in many industrial processes. When it is released following industrial use, it may be polluted and poisonous to living organisms. Another kind of pollution results from water being burdened with human waste materials in the form of sewage. Of course in all forms of pollution the water becomes purified when it is evaporated and taken back into the air.

Water cannot be created or destroyed except by physical or chemical means, but it can be rendered temporarily unusable. Water conservation consists of assuring a supply of pure or usable water in sufficient quantity for human use wherever and whenever it is needed. Specifically, water conservation involves prevention or removal of pollution, control of soil runoff, prevention of floods, impoundment in reservoirs, and other specific measures looking toward the overall goal.

Recently, there has been great interest and research in the desalination of sea water. Deriving usable water from the sea is going to be necessary because of greatly increased human needs. Rapidly growing human population and expanding industry in some areas are outrunning natural supplies of fresh water. Of course water derived from the sea through evaporation has always played a major role in the water cycle, but the time is approaching when this must be supplemented by artificial means in areas of concentrated human use. Unless a practical method of getting fresh water from the ocean can be devised, water may well become a limiting factor for man before food does.

Materials and Equipment:

1000 cc graduate cylinder

metal cooking vessel

Bunsen burner or other source of heat

Potted cactus or other plant without leaves

Potted geranium or other leafy plant approximately the same size as the cactus

Razor blade

Microscope

Slides and cover slips

Plastic bags

Tea kettle

Chart or other form of illustration showing different types of clouds

Newspaper or other source for daily weather map

Metal cylinders made from small juice cans with both ends removed

Watch with a second hand

Procedure:

1. Using a graduate cylinder to measure volume, put a predetermined amount of water into a metal cooking vessel. Let it stand at room temperature with the top off for 24 hours. Pour the remaining water back into the graduate cylinder. How much water evaporated over the 24 hour period? Calculate how long it would have taken for the entire volume of water to have evaporated at room temperature.
2. Put the same amount of water into the vessel and bring it to a boil over a source of heat. After 15 minutes allow it to cool and pour the remaining water into the graduate cylinder. How much water evaporated during 15 minutes of boiling? Calculate how long it would have taken for the entire volume to evaporate with boiling.
3. Compare the time involved for complete evaporation at room temperature and at the boiling point. How much more rapidly (5 times as rapidly, 10 times as rapidly, 100 times as rapidly) did evaporation occur at the boiling point than at room temperature? What do you think would happen at other temperatures? How is this related to the water cycle?
4. What are the three states in which water can exist? What is water vapor? Can you see it? Where does water go when it evaporates? What is meant by relative humidity? How is it calculated? How is dew formed? What is meant by dew point? How is dew related to frost? To rain?

5. Fasten plastic bags as closely as possible around:

a potted cactus or other leafless plant

a potted geranium or other leafy plant approximately the same size

The pots should be the same size, and both plants should receive the same amount of water at the time the bags are fastened around them. The bags should be fastened around the bases of the plants rather than around the pots, and should allow approximately the same amount of space inside the bag around each plant.

6. Place the plants side by side in the sunlight, and allow them to stand for a few hours. Remove them to a cool place, and allow them to stand until moisture droplets form on the inner surface of the plastic bags. Where did the moisture come from? What are the relationships involved? Is there any difference in the amount of moisture on the inside of the two bags? Can you suggest reasons for any differences that you observe? Why did the moisture not appear when the bags were in the sunlight? What is transpiration?

7. With a razor blade remove a small, thin portion of the surface layer of the cactus, and of the surface layer of a leaf of the other plant. See if you can tear off only the outer layer of cells in each case. This may require several attempts and a little practice. Put a specimen from each plant in a drop of water on a microscope slide. Examine with the lowest power of the microscope. Describe any differences in structure that you are able to observe. Look for minute openings called stomata. They are located among the surface layer of cells of the leaf. They have two small bean-shaped guard cells at the sides of the opening. What is the function of these openings? How are they related to the appearance of moisture on the inside of the plastic bag? Is there any difference in the number or appearance of the stomata on the surfaces of the two plants? Is the total amount of surface different in the two plants? How does this affect the total number of stomata?

8. What about the natural habitats of the two plants? Try to interrelate (a) the amount of moisture formed on the inside of the plastic bags, (b) the surface structure of the two plants (c) the total amount of surface of each plant, and (d) the natural habitat of each plant. What is the relationship? Why? How does the amount of water evaporated from an acre of green vegetation compare with that from an acre of open water?

9. Place a kettle full of water on a source of heat. Let it come to a boil. Watch the steam escape. Is there a small clear space between the opening of the spout of the actively boiling tea kettle and the steam? What is in this clear space? What is the relationship between water vapor and steam? Why?

10. Study clouds and learn the different kinds of clouds. Observe cumulus clouds closely. How long do they retain the same detailed structure? How are they related to water vapor? How are they related to steam? How are rain drops formed? Snowflakes? Hailstones?

11. What kinds of clouds are indicators of rain? What is the relationship of certain kinds of clouds and wind direction to areas of low and high pressure? Study the daily weather map. Look up information necessary to interpret it. Correlate your observations of clouds with what you find on the weather map. What does a farmer or other outdoorsman mean when he says, "It looks like rain"? What does he see that leads him to say this?

12. On your school ground select a number of different kinds of locations:

- a. Grassy plot
- b. Packed area where the grass has been killed by trampling
- c. Ground that has been cultivated and the surface soil loosened
- d. Others

Using a metal cylinder made by cutting both ends from a small juice can, push the cylinder tightly against or slightly into the soil surface in each location. Do this in such fashion that no water can leak out around the lower edge. Fill the can to the same level with water in each case. Using a watch with a second hand, determine how long it takes the water to soak into the soil in each case. Is the time different for the different locations? What can you say about soil permeability? What does surface vegetation have to do with it? How is soil permeability related to the run-off of surface water? How is it related to the water cycle?

Further Considerations:

How is the water cycle related to soil erosion? How is it related to flood control? How is it related to wildlife? How is it related to the location of human industry? To the distribution of human population and the location of cities? To the production of human food?

Outline the water cycle as a cycle, and show all of the side relationships that you can think of.

Days and Nights, Moons and Years

Introduction:

A practical use for naturally occurring cycles is the measurement of the passage of time. We think of the passage of time in terms of numbers of particular cycles that have passed. How would the passage of time seem to us if we did not have readily observable cycles with which to measure it? This is an interesting question which we cannot answer, because it is entirely hypothetical. We do not know anything about time passage without cycles.

Many years ago a science fiction writer, Edgar Rice Burroughs, wrote a book called At the Earth's Core, in which he imagined that the earth was hollow, with a concave world on the inside, kept lighted by a "sun" located at the center. This sun always stood still. There was no day and night. The climate was humid and tropical, and there were no seasons. Although people were born, lived and died, they had no way to measure time, and therefore no conception of its duration. Any moment seemed to last forever. We know that biological and psychological time do not necessarily correspond to physical time. Did you ever experience a moment that seemed like a much longer period? Can you think of other examples? How about differences in the rate at which people show the effects of age?

People have used various cycles to measure time. We speak of days, months, years, generations. All of these are based on natural cycles: the day-night alternation, the phases of the moon, the seasons, and the human life cycle. We also use other time measurements: minutes, hours, weeks, centuries, millennia. These are based on arbitrary time intervals rather than natural cycles.

Many primitive peoples were apparently better able to comprehend shorter cycles than longer ones. Thus they reckoned time in "moons" rather than years of the type that we use, based on the seasons. The American Indians are said to have reckoned time in "moons". Among agricultural peoples the alternation of "seed time and harvest" may have been used to mark the passage of time. Something akin to this is apparent in the thinking of farmers even in our own time.

The word "year" has been applied loosely to all of these cycles: the lunar period, the periodic occurrence of sowing and harvesting, the period marked by the passage of the seasons due to the orbiting of the earth around the sun. The word "day" has been similarly loosely applied. We say of an old man, "In his day he accomplished many things."

In this laboratory experience we will examine certain naturally-occurring cycles and their use in the measurement of time.

Materials and Equipment:

Source of information (almanac or daily newspaper giving weather and astronomical data) for time of sunrise and sunset

Calendar or almanac showing phases of the moon

Field glasses

Copy of the Christian Bible (any translation) or the Jewish Pentateuch

Daily weather maps (newspaper or other source)

Fever thermometer

Proceudre:

1. Locate a source of information that gives the time of sunrise and sunset each day. Calculate day-length for a period of successive days. How much does each day increase in length during the spring, and decrease during the fall? Is the amount of increase or decrease the same for each day? If not, does it exhibit a pattern? Does the increase or decrease occur at the beginning or end of the day? Or is it divided evenly between the beginning and the end? Is it always the same, or does it occur sometimes one way and sometimes another? Can you state a generalization concerning the progressive changes in day length? Why is this an example of directional change which, if observed over a long enough period, is really cyclic change?
2. When is the longest day in the year? The shortest day? Are the dates always the same? How is length of day related to the seasons? To temperature? To other environmental factors? What is "seasonal lag"? Under what conditions does it occur?
3. How is length of day related to the behavior of humans? Of other animals? Do we behave differently in seasons of longer days and shorter days? How? How is the singing of birds related to time of day? To light? How is bird migration related to day length? What are some animals that are active during the day (diurnal)? During the night (nocturnal)? During the morning and evening twilight periods (crepuscular)? How do Eskimos respond to periods of six months day and six months night in the far north? How do mammals other than man respond?
4. A lunar cycle is approximately 28 days long, from any particular point in one cycle to the corresponding point in the next cycle. What are the phases of the moon? Look them up on a calendar. Follow them by observing them on clear nights for a month. What causes the phases of the moon? Look at the moon through a pair of field glasses when it is full, and again when it is at either first quarter or third quarter. Can you distinguish craters, mountains and plains? See if you can distinguish the shadows of the lunar mountains at the edge of the dark portion. How long a period is a "day" on the moon? A "night"? Why do we never see the other side of the moon?
5. How many lunar cycles are there in a calendar year? How does this number compare with the number of months? How was the number of days in each calendar month determined?

6. The ages of the patriarchs, as given in the Bible in the Book of Genesis (also in the Jewish Pentateuch) are a part of our cultural heritage. Have you ever heard it said of a very old person, "He is as old as Methuselah!"? How old does the Bible say Methuselah was when he died? Read about the ages of the patriarchs in Chapter 5 of the Book of Genesis. Then divide the stated age of each of them by the number of lunar cycles in our calendar year. What is the result? How old really was Methuselah? How old were the others?
7. Among agricultural peoples the calendar year tends to be thought of in two more or less equal portions: "seedtime to harvest", and "harvest to seed time". If each of these periods was thought of by some of the early biblical peoples as a "year", so that one of our calendar years becomes two "years" in their reckoning, we have a possible explanation for some of the other ages given in the Book of Genesis.
8. Read the chapters in Genesis following Chapter 5. Look up especially the ages of Abraham and his wife Sarah when their son Issac was born. Look up the age of Jacob when he died, and the age of Moses when he died (Deuteronomy 34:7). Divide by two. If the hypothesis which has been suggested above is true, how old were they? Not all of the ages stated in Genesis fit either the "lunar year" hypothesis or the "agricultural year" hypothesis, but a large number of them do. What might have led the same tribe of people to use first the "lunar year" and later the "agricultural year" in their reckoning of time?
9. What animal activities are affected by lunar periods? See if you can find any specific examples. What effects does bright moonlight have on animal activity? Do birds ever sing when the moon is full? Why? What kinds of birds? What part have the phases of the moon played in human activities? In ancient religions? In the customs of primitive peoples? In folklore and superstition? Are plants ever affected by moonlight?
10. Moonlight is polarized light. How does polarized light differ from other light? Why is moonlight polarized? Is light reflected from a mirror polarized?
11. Study daily weather maps each day for a month. Observe the weather each day during the same period of time. Does the weather follow the map? To what extent are weather forecasts accurate? How are they made? How are the maps made? Visit a local weather station and see the scientific weather observers in action. Watch for the monthly long-range weather forecast in your local paper. How accurate is it? How is it made? How has weather forecasting become more efficient as a result of the orbiting of weather satellites?
12. Are there cycles of weather? How much is there to an old weather proverb such as, "If it rains on Easter Sunday, it will rain for seven Sundays after"? Do frontal systems (bringing storms and rainfall) tend to pass across the continental United States about once a week, especially during the spring and fall? Try this out as a hypothesis.

Study a series of daily weather maps to test it. Does this cycle hold for other parts of the world? Why or why not? Are there other weather cycles in other places? What about longer climatic cycles? Can you think of any reasons why weather and climatic cycles have not been used to measure the passage of time?

13. How long is a human generation (from birth to reproduction)? How many human generations, defined in this way, are there in a century? There is also a human "memory generation". How old is the oldest person that you know? When was this person born? If this person remembers a person of similar age who lived when he or she was a child, when would that person have been born? How many such memory generations have there been since the Civil War? Since the Revolutionary War? See how far back you can trace memory generations, starting with yourself. Have human generations ever been used to measure the passage of time? Which kind of human generation do we mean when we say that something happened "a generation ago"?
14. A number of physiological cycles take place in the bodies of humans and other animals. How many of these can you think of? What about the heart beat? Look up a description of heart action. Is it a cycle? What is an electrocardiogram? What does it show? What about body temperature? Is it always 98.6 degrees Fahrenheit when a person is healthy, or does it change each 24 hour period? Which is more stable, the body temperature of a child or that of an adult? Take your own temperature at intervals of four hours over two 24 hour periods. Is there a cycle? Find out about as many other physiological cycles as you can? Could you measure the passage of time with them? Why are they not used in this way?

Further Considerations:

What have people believed in the past about the effect of the phases of the moon on living organisms? Talk to old people whom you know, and write down as many moon proverbs as you can find. Are there any that you think might have a basis in fact? Why? Try out some of them by observation and/or experimentation.

After similarly questioning old people concerning weather proverbs, write down as many of these as you can. Which ones do you think might have a basis in fact? Why? Could you try out some of them by observation?

IX

Idea of Directional Change in Response to the Challenge of the Environment

1. Idea-Bridge: "Thinking About Evolution and Directional Change"
2. Laboratory Experiences:
 - a. "Normal Curves Describe Variation in Nature"
 - b. "Variability in Human Feet"
 - c. "Variation in a Population"
 - d. "Natural Selection at Work: A Field of Competition"
 - e. "Selection and the Gene Pool: A Working Model"
 - f. "Protective Coloration: A Mechanism for Survival"
 - g. "A Quantitative Study of Competition Between Species"
 - h. "A Mental Experience: Directional Change in the Human Species, the Long Line"
 - *i. "Extensions of Man's Body: How They Have Evolved"

*Included in Bulletin No. 313, NDEA Title III, Open-Ended Laboratory-Centered Science for Grades 7-8-9. Michigan Department of Public Instruction, Lansing, Michigan, 1965.

Thinking About Evolution and Directional Change

The idea involved in an understanding of evolution can be stated rather simply: Variation, plus the survival of that which "works", results in evolution. If you wish to set up a symbolic expression of it you can easily do so:

$$V + S = E$$

in which V = variation

S = survival by natural selection
of that which works

E = evolution (generally
directional change)

Evolution is the process of change, change in plant and animal forms, change in the physical world, and change in the social world of habits, customs, ideas, beliefs, what man does, and the things he has invented and uses. It is the continuous adjustment of anything to the demands of a changed or changing environment. It does not always consist of directional change, but it usually does. Some if it is due to chance, but most of it is due to the selective action of the environment, acting on something that exhibits variation.

Evolution results from a combination of two of the basic behaviors which scientists have found to be general properties of nature. They have learned to expect nature to show variation and change. They have also learned that in nature that which "works" survives and tends to perpetuate itself (or be perpetuated), rather than that which does not "work", or that which "works" less well. When variation and change interact with survival and perpetuation, whether in biological nature, physical nature, or the various modifications and applications of nature that man has made, evolution, generally in the form of directional change, is the result.

Although we usually think of variation in connection with living organisms, it is by no means limited to them. All kinds of things exhibit variation. The inventions and innovations in man's tools, machines, and other devices are directly comparable to the mutations that occur among living organisms. The various possible solutions that we think of to meet our life problems, and try, one at a time, until we find one that works, are also comparable to the variations that we see in nature.

The same is true of variant forms of social and political systems, of variant forms of group activity, of new philosophical ideas and interpretations, of the development of new words and forms of expression in a language, of new styles and types of clothing.

In the natural world, even though atoms, molecules, crystals, and other basic physical particles and structures are presumably identical or closely similar at the level of detail at which we are able to examine them, the aggregates of these (stones, beds of rock, pieces of ore, chunks of metal, mountains, lakes and rivers, air masses, solids, liquids,

and gases) show variation and change. Physical processes--such as erosion, deposition, rate of flow, rate of evaporation, rate of chemical reaction--all vary.

The other characteristic of nature on which evolution depends is the survival of that which is operationally successful. This, likewise, is equally characteristic of living nature, of that which man makes and does, and of non-living nature, insofar as it exhibits variation and change. That which "works" survives, and that which does not "work", or that which "works" less well is eliminated, either immediately or eventually. A single failure will not necessarily defeat or destroy it, but continued failure will do so. Nothing can continue to exist if, in the long run, it is consistently unsuccessful.

This is as true for an individual's failure to find a solution for or adjust to a life situation, or the failure of the buying public to accept an innovation in the design of an automobile, or the failure of a new laboratory experience to succeed with a class, or the failure of a new word to find a permanent place in the language, or the failure of a new political movement to succeed, as it is of the failure of a white squirrel to survive in nature.

And survival alone is not enough. That which survives must perpetuate itself (or be perpetuated) if it is to continue to be a factor in the world. Survival generally implies perpetuation, but not always. A rabbit showing a particular variation may live through the winter, but may not be strong enough to mate and produce young when spring comes. An innovation in clothing may be widely used for a year, but then pass out of use and be forgotten, while another takes its place. A new song or play or novel may enjoy temporary popularity, but not turn out to be one which will become a classic and "live" into the next century, or become a starting point of a new literary style. Many temporarily successful variations (mutations, innovations) are like this.

If, however, the variation (mutation, innovation) "works" and is successful, if it "works" better and is more successful than other forms, and if its perpetuation is possible, it will continue to survive. If the situation involves competition, it will ultimately displace the less successful forms.

This is change, So long as the situation which determines success or failure remains the same, and variations are available on which it can operate, the change will continue in the same direction and will make for more and more successful adjustment to the demands of the situation. This is evolution, regardless of whether it occurs among living organisms or in the physical or social world.

*Normal Distribution Curves Describe Variation in Nature

Introduction:

There is variation in everything. Sometimes we are able to account for these differences. More often we are not able to do so. They are accepted as a fact of nature. Darwin assumed as a fundamental fact that no two living organisms are alike. He made this one of the bases for his theory of evolution through natural selection. Darwin did not know about genetic mutation, which we now know interacts with the environment to cause variation.

In nature even among offspring of the same parentage, the interplay of genetic and environmental factors results in a wide range of variation among organisms of the same kind. It is rarely possible to adequately describe two or more living things by saying that they are "as alike as two peas in a pod". Even in cases where we can do so, close inspection and measurement will show that there are detectable differences. Among people only identical twins are nearly alike. They possess identical heredity, but even with them, slight differences may occur due to the influence of environment.

One way to see the occurrence of variation and its distribution in nature is by measuring a collection lima bean seeds.

Materials and Equipment:

1 lb. dry lima bean seeds of the same kind
(either large or "baby" limas)

12 large test tubes and a test tube rack (4 oz. fruit juice glasses or wine glasses may be substituted, if they are made of clear, transparent glass)

Magnifying glass

Millimeter rule

Glass marking pencil

Graph paper

Simple balance measuring weight in grams and fractions of grams

Procedure:

This experience is best carried out by individual students or by students working in pairs. The final results obtained by the individuals or pairs may be combined at the end of the experience to provide a larger sample.

* In collaboration with Dr. Sylvan Mikelson, School of Education, Wayne State University, Detroit, Michigan, and his graduate students..

Measure the beans in groups of ten. Each "ten" should be selected at random, e.g., counted as they are poured out of a bag or other container.

Measure the greatest length of each bean with the millimeter rule. Determine the length to the nearest millimeter, using the magnifying glass for close distinction. You will soon develop a skill in doing this, such that the job will proceed relatively rapidly.

When you have measured the first bean, file it in a test tube or glass, and mark the length on the glass. Do this with the second bean, if it is a different length, or file it in the same container if it is the same length. Continue until you have completed the first group of ten, setting up a new container every time you find a bean of a different length. Do your containers form a continuous series (e.g., 12 mm., 13mm., 14mm., 15mm., 16mm., etc.), or is the series incomplete? Have the beans begun to "pile up" in one of the containers? When they do so, the length which occurs most frequently is called a mode. Where is it located in the series? Is there more than one mode? Write down your answers to these questions.

Measure a second group of ten, proceeding as before. When you have completed it, answer the same questions asked at the completion of the first group of ten, and record your answers. Are the answers the same? If they are different, in what ways do they differ? Continue with a third group of ten, record the answers. Follow with additional "tens", as long as you have time to or care to continue the experience. Keep a record of the number of "tens" that you have measured.

How many "tens" did you have to measure before new size classes ceased to appear? How many "tens" did you have to measure before a definite mode became apparent? In which "tens" did you find the longest and shortest extremes of the population? Does this tell you anything about the probability of pulling a single bean at random from the population, which would be representative of one of these extremes? When a single specimen of an extinct race of man is discovered which differs widely from modern man, what do you think of the argument that it is a "freak"? How valid do you think it is to generalize on the basis of a single, interesting case in dealing with any kind of data?

How many "tens" do you think it took to constitute an adequate sample of the bean population? Would your conclusions concerning the nature of the population have changed if you had continued beyond this point? Try to frame a definition of an "adequate sample" which would be applicable to any kind of population.

Count the total number of beans in each size class, and construct a graph showing the relationship of sizes to the numbers in each size class.

Numbers

Sizes (length in mm.)

To what extent does the graph showing your results approximate a normal curve? Would measurement of a larger sample have given you a better curve? On the basis of your graph, do you wish to modify your conclusions concerning the size of an adequate sample? Do you wish to add to, or modify your definition of an adequate sample?

Combine the results obtained by other members of the class. Construct a similar graph showing results from the entire class. Do you get a better curve? If so, why? Is there a change in either the extremes of the population or the mode when the results of the entire class are combined? Do you wish at this time to further modify your conclusions concerning the size of an adequate sample?

Further Considerations:

How do political poll takers determine what constitutes an adequate sample? What factors in addition to size of the sample do they have to take into consideration? How accurate are their results?

As you measured the lima beans, did you notice any other kinds of variation other than length of the seed? How about width of the seed? Shape of the seed? If you were to weigh all of the seeds in each size class, or an adequate sample of them, do you think that the weight of each seed would necessarily bear the same relation to their common length? Or would there be a normal curve of different weights within each size class? Try this and see, if you have available a simple balance, measuring weight in grams and fractions of grams.

What about other kinds of seeds? Nuts? Fruits? Leaves? What about various kinds of common animals? What about humans? Is the kind of variation which you have studied in lima beans characteristic of all forms of life? Do you think that you could set up normal distribution curves for variation occurring in other living things? Try it in any case where you can obtain a sufficiently large population to constitute an adequate sample.

What about variation in non-living things in nature? What about variation in things that man has made? How would you describe variation in the classes of things that man has made? Does it differ from variation in living nature? In non-living nature? How? Why?

Can variation among living things be related to survival in nature? How? What would be the equivalent of "survival" in the case of man-made things? Would the equivalent of "variation" in the case of man-made things be related to this? How?

*Variability in Human Feet

Introduction:

Everyone is aware of differences in shoe sizes. They are a standardized means of expression of variations in the shape and size of people's feet. Even so, the standardization fails to take into account many individual variations. Do you have difficulty getting fitted in shoes? Do you have difficulty wearing certain styles of shoes? Are both of your feet alike?

Many of the characteristics of people's feet can be expressed in terms of the ratios of certain measurements to one another. In terms of variation within a population, these characteristics can be shown in the form of graphs and scattergrams. All you need to do to study them is to make and record a series of measurements on a group of people of comparable age. Would it be well to consider the measurements of boys' and girls' feet separately? Try to find an answer to this question as you go along.

Materials and Equipment:

18-inch rule cut from a yardstick, for measuring feet

The remainder of the yardstick, cut into two 9-inch lengths

Steel carpenter's tape, for measuring height

Graph paper

A group of people of comparable age (a class of about 30 individuals)

Procedure:

Students should work in pairs, each making measurements on the other, and checking each other in recording data.

Measure the length of the right foot to the nearest half-inch, from the heel to the tip of the big toe. Do this by placing the foot on the 18-inch rule, and setting one of the 9-inch rules at right angles to the 18-inch rule snugly behind the heel, and the other snugly in front of the big toe. Collect the foot lengths of all members of the group, and construct a graph showing the range of variation in foot length in the group:

Numbers of
individuals



Foot length (half-inches)

*In collaboration with Dr. Beth Schultz, Department of Biology, Western Michigan University, and Diane Exworthy and Ted Gottshall, students in the Department.

If both boys and girls are included in the group, do the boys tend to be in one part of the range, and the girls in the other? You may represent this by making three distributions on your graph, one to include boys only, one girls only and one the entire group. You may use black and red lines to distinguish boys and girls, and a third color for the line representing the entire group.

Now measure the height of each individual to the nearest inch, and set up a ratio for each individual:

length of foot in inches : height in inches (e.g., 8.5 : 67)

Compare the ratios for all members of the group. Is there any consistent relationship between height and length of feet? Do tall people always have bigger feet? Do short people always have smaller feet? Is the left foot the same as the right? What is the relationship between foot length and size of shoe worn? Is the relationship the same for children's sizes and adult sizes? For men's sizes and women's sizes?

You can study the relationship of foot length to height for the entire group by constructing a scattergram. Do this in the same way that you constructed the graph showing distribution of foot length, except that in this case the horizontal axis of the graph shows foot length, and the vertical axis shows height. Each individual in the group is represented by a dot at the point where the lines representing his height and foot length intersect:

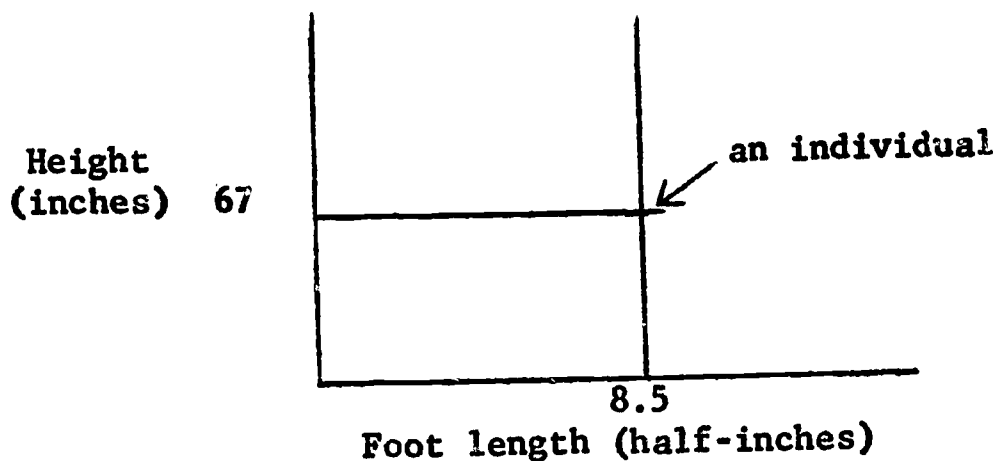

In plotting the entire group in this fashion, if two individuals should happen to show identical foot length and height, and thus be represented by the same point, this can be shown by placing a small (2) near the point. In a group the size that you are measuring, such duplication is unlikely. If both boys and girls are included in the group, black dots may be used for one, and red dots for the other.

In this scattergram, if the heights and foot lengths were to show a direct correlation in all cases, all of the dots representing individuals would be in a diagonal straight line rising from the lower left to the upper right. Why? Does the actual distribution of the dots give any indication of an approach to such a correlation? Does the scattergram give you a picture of the relationship of foot length to height in the population represented by this small group?

Now measure the greatest width of the right foot to the nearest quarter-inch. The greatest width is found across the ball of the foot, in front of the arch, at about the point where the toe bones attach to the body of the foot. Proceed as you did in measuring the length, by using three rules, two set up at right angles at the sides of the foot.

Construct a scattergram for foot width in relation to height. Here again you may use black and red dots to distinguish boys and girls:

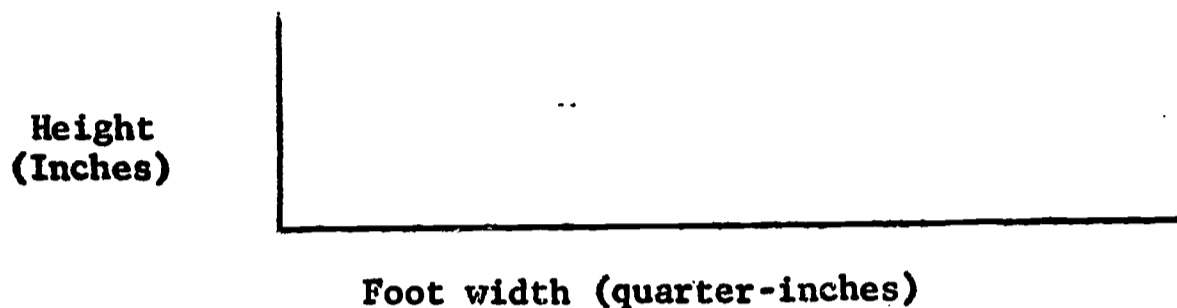

Is there any correlation between foot width and height? Do tall people tend to have narrow feet? Do short people tend to have broad feet? Is the opposite true? Compare the picture shown in this scattergram with that for foot length and height. Are they similar? Are there any apparent differences? Can you make any generalizations about either foot length or width in relation to height? Is the left foot the same width as the right foot? What is the relationship between width of foot and shoe size? How is width of foot expressed in terms of shoe size?

Now set up a scattergram to show the relationship between width and length of foot. Again you may use black and red dots to distinguish boys and girls:

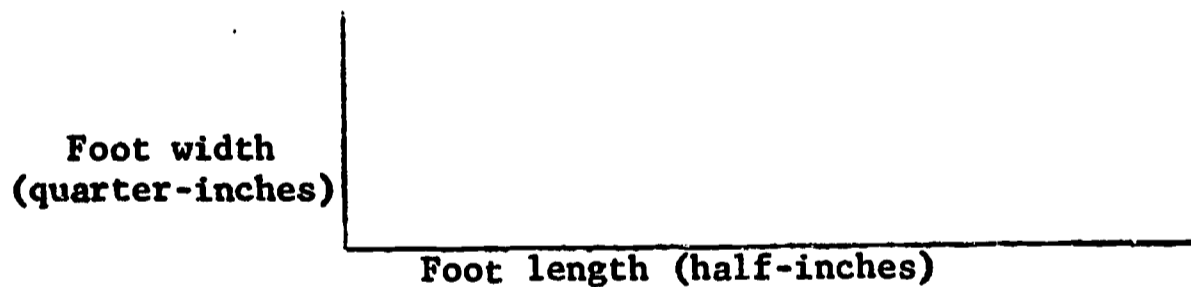

Is there any correlation? What kind of picture do you get? Note the dots representing individuals with long, narrow feet. With short, broad feet. Are there any with long, broad feet? With short, narrow feet? Find out by inquiry within the group if there are any individuals who have difficulty getting fitted with shoes. Note what type of feet they have. Do you think that the relative numbers of such types which occur is in any way related to their difficulty in finding suitable shoes? Why?

Now determine the distance from the tip of the big toe backward to the line which marks the greatest width of the foot. Measure this distance to the nearest half-inch. Set up a ratio of this distance to total length of foot:

distance from tip of big toe to line of greatest width : total
length of foot (e.g., 2.5 : 8.5)

Again compare the ratios for all members of the group. Is there any consistent relationship? What effect do you think that differences in this relationship might have on the relative degree of comfort one would find in wearing different styles of shoes? Set up a scattergram showing this relationship for the group:

Tip of big toe to
line of greatest
width --
(half-inches)



Foot length (half-inches)

Is there any correlation? What kind of picture do you get? Compare it with the picture obtained for the relationship of foot width to foot length. How important do you think this relationship is? To what extent do shoe stylists and manufacturers take it into account? To what extent do purchasers of shoes take it into account? To what extent should they do so?

Now establish an arbitrary line at right angles to the length of the foot three inches in front of the tip of the big toe. Then measure the distance to the nearest quarter-inch from this line backward to the tip of the second toe. Set up a ratio of these two distances to one another:

distance to tip of big toe (3 in.) : distance to tip of
second toe (e.g., 3 : 3.25)

Compare with all other members of the group. How much variation do you find? In what percentage of the cases is the big toe longer than the second toe? In what percentage are the two equal in length? In what percentage is the second toe longer than the big toe?

Now measure from the same arbitrary line backward to the tip of the little toe (fifth toe). Again measure to the nearest quarter-inch. Set up a similar ratio:

distance to tip of big toe (3 in.) : distance to tip of
little toe (e.g., 3 : 4.75)

Compare with all other members of the group. How much variation do you find? In terms of the relative distances from the arbitrary line to (1) the big toe, (2) the second toe, and (3) the little toe, describe in broad terms the profile of the end of each person's foot. Draw this profile for each member of the group on a piece of plain paper, first drawing a horizontal reference line, equal in length to the previously determined greatest width of the foot. Now measure the distances to the tips of the

third and fourth toes and include these in the profile. Do they change its general character?

Summarize what you have learned in this laboratory experience with regard to variation in foot shapes and sizes. To what extent have you added to your understanding of variation as a general characteristic of the natural world?

Further Considerations:

What other relationships can you think of that would add to your picture of variability in the shapes and sizes of human feet? Think in terms of how you would measure them. What additional individual differences and peculiarities have you observed in connection with your study of the feet of the group? What others do you know of that were not observed in the group? Do you know of any in your own family? In the families of others?

Foot characteristics are often strongly hereditary in families. Can you trace any of these in your own family? How far back? Are your feet like those of your parents? Do they more strongly resemble the feet of one parent than the other? Look up information on the heredity of foot characteristics.

What about hand characteristics? These are also strongly hereditary. Do your hands show any characteristics similar to those of your feet? If so, why might you expect this to be true? What about the hands of other members of the group?

See if you can find out about any hand or foot characteristics that might be detrimental to successful adjustment to human living. What effect do you think this might have on the survival and perpetuation of these characteristics in the race? What is meant by the "human gene pool"?

Variation in a Population

Introduction:

Variations within populations of plants and animals in nature constitute the raw material upon which natural selection works to produce evolutionary change. Of course not all of these variations are inherited. Some are due to the operation of the environment during development. If, however, we study the individuals of a population which has developed in what appears to be a uniform environment, and find readily apparent variations occurring among them, we may assume that these are probably due to hereditary differences.

Since plants do not move around, they are easier to study than animals, and are more likely to develop under a uniform environment. Furthermore, it is often easier to find large populations of a single kind of plant than of a single kind of animal. This is favorable from the standpoint of discovering and studying variations. We are all familiar with large populations of domestic plants (e.g., corn, wheat, soy beans, potatoes, domestic flowers.) Wild flowers also frequently occur in large populations.

For this laboratory experience we have chosen a very common wild flower of the eastern deciduous forest region of North America, which exhibits a wide range of variations. A person wishing to carry on this laboratory experience in a different region can easily substitute a species of wild flower common to that region which exhibits a similar wide range of variation.

Equipment and Materials:

An available area where relatively large populations of common wild flowers can be studied.

A field guide for identifying them (Rickett, Harold W., American Wild Flowers, G.P. Putnam's Sons, New York for the eastern United States.)

Procedure:

1. Find a spot in open woods or forest edge in spring, where the ground is covered with a large population of the small wild flower, spring beauty (Claytonia virginica). This is easy to do anywhere in the eastern deciduous forest region of North America, since spring beauty is one of the commonest of spring wild flowers.
2. Observe carefully all variations in flower type that you can discover. In spring beauty such variations are common, particularly in shade of color, shape of petals, and size of petals. Write down descriptions of as many variations as you can find. Draw sketches of them if you wish. Do you find that these variations can be grouped into a few definite categories? If so, is there a range of variation within each category? Can such variations within a category be described in terms of a normal curve? If not, how can they be described? Are individuals exhibiting certain variations more numerous than others? What do you suppose may

have caused such differences in number? Natural selection? Location? Chance? Any other cause? Justify your answer.

3. In spring beauty, the population in any particular limited area, such as that under a single tree, seems to be divisible into a series of "clones" or clusters of plants having flowers of similar type. Why do you think this is so? Does the plant's method of reproduction have anything to do with it? How does spring beauty reproduce? Does it have more than one method of reproduction?

In case you are using some flower other than spring beauty, see if you can determine a relationship between the distribution of variant individuals in the population and the method of reproduction. Would a mutation occurring in a plant having a vegetative method of reproduction have a better chance of surviving in a population than a mutation occurring in a plant that reproduces by seeds only? Why, or why not?

4. Can you think of any reasons why some of the variations that you have observed in spring beauty might be more survivable than others in the environment in which the plant occurs? Can you see any variations that you think might be valuable to the plant? Any that might be detrimental? Why? Are the numbers of individuals of the different variant types related in any way to the apparent survivability or non-survivability of these types? If not, are they related to anything that you can discover? Can you devise a hypothesis to explain what you find?

Further Studies:

Repeat the experience with one or more species of flowers other than spring beauty (or whatever species you used in your original study). Do you find more or less variation than in your first species? Devise a hypothesis to attempt to explain what you find. Is there as much variability among domestic flowers as there is among wild species? Why, or why not? What part do you think that the kind of variation that you have been observing plays in evolution?

Natural Selection at Work: A Field of Competition

Introduction:

Selection among living organisms in nature occurs as a result of elimination of the least fit. These are the members of a species that are unable to survive under the conditions that the environment presents. They are not "good enough to get by." It is like a game in which those who are not able to compete are eliminated from further competition. Athletics--all kinds of games--are like this. We compete for grades, for social acceptance, to "keep up with the Joneses."

This laboratory experience is a "tournament" (like a basketball tournament) to determine which student in the class is able to put a simple puzzle together in the shortest time. Since we will run a series of contests, using the same puzzle, the ability to improve the skill involved in putting the puzzle together will play an important part in determining who will be the winner.

In each series of contests it is the least skilled that are eliminated, but the process continues through many series of contests, so in the end, it is the most skilled, or those individuals who are capable of becoming the most skilled, that survive. It is much the same among living organisms in nature.

Materials and Equipment:

Filing cards, 3" x 5"

Tags

Scissors

Envelopes

Ruler

Procedure:

1. For this laboratory experience a simple puzzle should be prepared for each member of the class. All puzzles should be made according to the same pattern. Each one consists of a 3" x 5" filing card cut into 10 pieces. (This is the same kind of puzzle that was used in the laboratory experience entitled A Simple Learning Curve.)

The 10 pieces into which the card is cut should be approximately the same size, and of as many shapes as possible. The cuts, however, must all be along straight lines. It is best to draw lines (lightly with pencil) to indicate the cuts before doing the cutting. The pieces of each puzzle should be placed in an envelope and given to the students, but neither pieces nor envelopes should be marked in any way.

2. A series of numbered tags, beginning with (1), should be prepared, equal to the number of students in the class. These should be shaken up, and each member of the class should draw a number. This will determine his participation in the first series of contests.
3. Students will contest in pairs. As many pairs may contest at a time as there are umpires to watch them. Students who are not contesting at a particular time may serve as umpires. In each contest the student who gets the puzzle together first is the winner.
4. Each student will contest three times in each series of trials. For the first trial, the pairs numbered (1) and (2), (3) and (4), (5) and (6), (7) and (8), and following, will contest. For the second trial, numbers (1) and (3), (2) and (4), (5) and (7), (6) and (8), and following, will contest. For the third trial, numbers (1) and (4), (2) and (3), (5) and (8), (6) and (7), and following, will contest. Students losing all three of the contests will retire from the game.
5. The numbers should be collected at this point. The remaining students who are still in the game will draw new numbers in a series beginning with (1). They will repeat the process, each contesting three times in the same numerical order as before, using the same puzzle. Again the three-time losers will retire from the game.
6. Additional contests following the same pattern will continue until all students except one have been eliminated. This remaining student will be declared winner of the tournament. If more than one class group has been engaged in the same laboratory experience, the "champion" of one class group may contest with the "champion" of another. This may be done if the same puzzle has been used in both classes. If different puzzles have been used, the situation would not be comparable. Why not?

How is this laboratory experience like selection in nature? How is it different? How is it like competition in the field of business or politics? How is it different?

Further Considerations:

Can you think of ways to modify the experience to give everybody a better chance to compete? Should everybody get a chance to compete with everybody else in the first series of contests? Should each of those remaining in the second and later series of contests get a chance to compete with each other person remaining in the same series? Would this give more reliable results? Try it with a new puzzle, and see if the results are the same or different. Why might the results be the same? Why might they be different?

Try other skills in competition. What about an old-fashioned spelling match? This would be a contest involving correctness rather than speed. What about an old fashioned "ciphering" match (working simple arithmetic problems in the skills of adding, subtracting, multiplying, and dividing)? This would be a contest involving correctness along with speed. Can you

think of other possibilities? What about manual skills? If you try some of these other kinds of competition, do you find that the same persons tend to win different ones? If so, what does this indicate about patterns of abilities? If not, what does it indicate about such patterns?

If we wish to find out which student can put the puzzle together most quickly, why not simply time each student with a stop watch? What would we have missed if we had done this instead of what we did?

How does natural selection work in terms of adaptation to the environment? In terms of directional change in nature? Is all change evolution? Are there any factors other than natural selection at work in evolution? If so, what are they? How important are they? Do you think that natural selection is working in the case of man? If so, what kinds of changes is it producing?

Selection and the Gene Pool: A Working Model

Introduction:

Inherited characteristics in man and other species of animals, and in plants, are brought about by determining agents called genes, which are carried in the nuclei of all of the cells of which an individual is composed. These genes are passed from parents to their offspring through the germ cells (sperm and ovum) which come together at the beginning of each individual's life, and unite to form the single cell from which the new individual starts. This single cell is called the fertilized ovum or zygote.

The two germ cells (called gametes) are in reality only half-cells from the standpoint of the hereditary material that they contain. The two half-cells, when they unite, make a whole cell, the fertilized ovum. This makes it possible for the amount of hereditary material in the form of genes to remain constant from generation to generation.

All of the genes that are found in all of the individuals belonging to a particular species (such as man) may be thought of as making up a single huge mass or pool. Each individual then consists of a temporary sampling of genes drawn from this pool, and if he or she leaves descendants, these genes are eventually poured back into the pool.

Imagine the gene pool of a species to be comparable to a swimming pool filled with water. Each individual of the species, then, is a cup of water drawn from the pool. If he or she does not reproduce, the cup of water is poured out onto the ground.

A human pair must produce at least two children to replace themselves in the population. If they produce only one child, then another pair must produce three to replace themselves and one of the first pair. In this case a part of the two cups of water representing the first couple is poured out onto the ground, and only a part back into the pool. In the case of the second couple, the equivalent of three cups of water are poured back into the pool for the two taken out. Thus the gene combinations found in the second couple are favored in the next generation, while those found in the first couple are partially eliminated.

The gene pool of the species, therefore, slowly changes, with an increase in the percentage of those genes which are found in individuals that reproduce to a greater extent, and a decrease in the percentage of those genes which are found in individuals that reproduce to a lesser extent. If there is any factor which interferes with or cuts down the rate of reproduction in the case of a particular gene or combination of genes, and this factor operates constantly and consistently over a number of generations, then this gene or gene combination will ultimately be eliminated from the gene pool, and will be replaced by a more successful gene or gene combination.

There are many kinds of factors which may operate to cut down reproduction of certain genes and gene combinations. Their operation brings about the process

called natural selection. A factor which brings about natural selection is said to exercise selection pressure on the gene pool. So long as the factor continues to operate, selection pressure modifies the gene pool in a particular direction. This results in directional change in the species.

It is possible to set up a model for the operation of natural selection on a gene pool representing a species. For this it is necessary to utilize objects such as beans, or corn grains, or buttons, which are all the same size and shape, but are two different colors. When equal numbers of objects of the two colors are put into a container, and two of the objects are withdrawn at a time, each withdrawal constitutes a working model of a single individual, resulting from the union of two gametes, a sperm and an ovum, to form a zygote.

Genes exist in pairs, one member of each pair being contributed by each parent. When the members of the pair are identical, then a trait, such as black coat color, is produced in the individual having the pair of genes in its cells. However, a gene may mutate (change its nature and the way in which it expresses itself). When this has happened, the gene pair may exist in an individual in any one of three different combinations:

A A (both members of the pair have the original form)

a a (both members of the pair have the new or mutated form)

A a (one member of the pair has the original and the other has the mutated form)

If an individual carrying the A A combination has black coat color, an individual having the a a combination might have white coat color. An individual carrying the A a combination might have gray (mixed) coat color, if the two genes interacted with one another on an equal basis, or might be black or white, if either the "A" gene or the "a" gene were strong enough in its expression to overcome its partner.

In our model we will assume that if a withdrawal consists of two objects of one color (Color A), the individual resulting from the combination will live and reproduce. Therefore we will put the two objects back into the pool. If a withdrawal consists of two objects of the other color (Color B), we will assume that the resulting individual will die, or at least will not reproduce. A gene combination that produces death in interaction with the environment is called a lethal. We will permanently remove the two objects representing the pair of lethal genes from the pool, and replace them with two objects of the other color. We will replace them because if the population of a changing species keeps the same total number from generation to generation, the place of the dying or non-reproducing individuals is normally taken by an equal number of descendants of the more successful gene combinations.

In case a withdrawal consists of one object of one color and one of the other, we will put them both back into the pool, because we will assume that the lethal gene only operates when it is doubled (pure or homozygous), and is not operative when it is paired with one of the opposite type (mixed or

heterozygous). Such a gene, whose expression can be covered up by the opposite member of the pair, is said to be recessive. In this case, the normal gene is said to be dominant to the lethal one.

In the case that we have outlined, either an A A (homozygous normal) combination, or an A a (heterozygous) combination, will survive and leave an adequate number of descendants, but an a a (homozygous recessive lethal) combination will be eliminated. We would expect, therefore, that natural selection would ultimately eliminate the lethal "a" genes from the gene pool, and consequently from the species.

Equipment and Materials:

200 objects (beans, corn grains, buttons) of one color (Color A)

100 objects of the same kind and size, of a second and easily distinguishable color (Color B)

Paper or cloth bag or other container of appropriate size, and of such nature that the investigator can pass his hand inside it and withdraw objects from it without observing its contents.

Graph paper

Procedure:

Students should work in pairs, one member of the pair doing the manual operations, and the other serving as recorder. They may trade jobs as often as they wish.

1. Place 100 objects of Color A, and 100 of Color B in the container described above. Place the remaining 100 of Color A in a second container (the "kitty").
2. Shake the 200 objects (100 of each color) in the first container to make sure that they are well mixed. Do this at least one time for each 10 withdrawals during the progress of the experience.
3. Withdraw two objects at a time. If both are Color A, return them to the container. If one is Color A and one Color B, return them to the container. If both are Color B (representing a homozygous recessive lethal combination) put them in a third container, and replace them in the first container with two objects of Color A taken from the "kitty". In this way the population of genes in the gene pool is maintained at a constant level. Why is this necessary from the standpoint of getting valid results from the working model?
4. Continue to withdraw pairs of the objects until 100 pairs have been withdrawn. In each case proceed as you did in the case of the first pair. Consider a group of 100 withdrawals as constituting a "generation". How many of the recessive genes (Color B) were eliminated in the first generation? What percentage of the total number of recessive genes originally in the population did these constitute?

5. Continue to withdraw pairs in generations of 100, until three successive generations have been withdrawn which result in no further elimination of recessive pairs. At this point it can be assumed that for practical purposes the recessive genes have been eliminated from the population. Why? Are the recessive genes all eliminated? What percentage of the original total of Color B genes still remains in the pool? Will the recessive genes ever all be eliminated? Why or why not?
6. Construct a graph showing the progressive elimination of the recessive genes in terms of percentage:

Percentage of original
number of recessive genes



Number of generations

Does the line on the graph constitute a gradient? Why? Are there irregularities in it? Why? What do you think would be the result of carrying the experiment through additional generations? Why?

7. Compare your results with those obtained by other pairs of students. Are there similarities? Are there differences? Why do you think each occurred?

Further Considerations:

Think of the results of the experience in terms of what you know or can find out by reading concerning the human gene pool. Do you know of any human traits that are present in the human gene pool in very low percentages, and therefore show up in individuals only occasionally? Are any of these lethal or partially so? What happens to them in terms of natural selection? Does modern medical science interfere with the operation of natural selection? How? Why? What do you think of this? Why?

Lethal genes may operate at different periods of life. They tend, however, to operate consistently at the same period of life for different members of the same family. What do you think about the probability of survival of a gene in the gene pool which interacts with the environment to produce a fatal type of heart disease in members of a family in their sixties? Compare this with the probability of survival of a gene in the gene pool which interacts with the environment to produce a fatal disease in members of a family in childhood? What does time of expression of a lethal gene have to do with the probability of its remaining in the gene pool? Why?

Can you think of any human traits that are present in the human gene pool in very high percentages? Are these normal or abnormal traits? Can you think of any traits that are present in percentages that are somewhere between high and low? Are these normal or abnormal traits? Would it be possible to construct a gradient of the percentages of genes in the the gene pool for various human traits? If you did so, where on the gradient do you think the abnormal traits would be located? Why?

If a recessive mutation advantageous to a species were to occur in a single individual, do you think it would be possible for it to increase in the gene pool to a point where it would take over in the species and replace the dominant form, which was less advantageous?

Has natural selection operated in the human gene pool in the past? How has it changed man? Is it operating now? If so, how is it operating? In what direction? In terms of what specific traits? Is this evolution? What is evolution?

*Protective Coloration: A Mechanism for Survival

Introduction:

One of the ways in which living organisms, particularly animals, survive in nature is to look like something else. A non-poisonous snake has a color pattern similar to that of a poisonous species. An insect looks like a leaf or a twig. A small mammal has the same color as the soil. A small bird has the same color as the environment where it is active. A young deer is spotted in a way that matches the pattern of sunlight in the forest or forest edge shrubbery. Army field uniforms are colored to match the background. It is possible to survive by being inconspicuous, and protective coloration is one way of not being noticed.

All of these things are facts that are widely known, easily told, and taken for granted. It is possible to set up a laboratory experience which will enable students to see for themselves and measure the effectiveness of protective coloration. The experience itself is simple, although preparation for it takes time and effort.

Materials and Equipment:

Poster paint (water soluble) in the following colors:

Green

Blue

Brown

White

Yellow (a double quantity)

White poster paper

Paper punch

Watch or stop watch

Baby food jars, or other small containers of uniform size

Quart jars, or other larger containers of uniform size

Pegs and string

Yardstick or carpenters' tape

Graph paper

Accessibility to a freshly mowed lawn and/or a sandy beach

*For technical advice with regard to colors, paints, and paper, the author is indebted to Labadie Arts and Crafts, Kalamazoo, Michigan.

Procedure:

Note: This laboratory experience can well be carried out by teams of four students.

1. Mix yellow, green, and blue paints to produce a series of shades by dilution: (a) green toward blue, and (b) green toward yellow. You may thin the paints with water if necessary. Place each shade or color in a separate baby food jar or other small container. Keep a record of the dilutions used.
2. Mix brown, yellow, and white paints to produce a series of shades by dilution: (a) yellow toward brown, and (b) yellow toward white. Thin if necessary. Place each shade in a separate small container. Keep a record of the dilutions used.
3. Color one piece of poster paper uniformly with each of the shades you have produced.
4. With the paper punch, punch out as many small circles as possible from each piece of colored poster paper. Place all of the circles of the same shade in a separate large container.
5. Measure off on a freshly mowed lawn and/or on a sandy beach, areas 3 yards square. It will probably be necessary to carry on the lawn portion of the experience and then move some distance to the beach to carry on the rest of the experience there. Mark the areas in each case by pegging the corners and running strings attached to the pegs along the borders.
6. With a team of four, one student can hold the watch, another can keep records, and the other two can carry on the experience. Later the jobs can be exchanged, and the first two students can carry on the experience.
7. Scatter a large quantity of the circles colored with the various yellow-green-blue shades over one of the 3-yard-square areas on the lawn for each student carrying on the experience. Scatter a large quantity of the circles colored with the various white-yellow-brown shades over one of the 3-yard-square areas on the beach for each student carrying on the experience. Be sure to scatter the circles colored with each shade uniformly over the area. Why?

Note: Using poster paper, which possesses some thickness, it should be possible to recover a fair percentage of the circles for re-use after each student completes the experience. Nevertheless, many of them will be lost, and a new supply will have to be prepared periodically. In renewing the supply, be sure to use the same paint dilutions to produce the different shades. Follow the record made when the dilutions were originally prepared. Prepare new plots for each student. Do not attempt to re-use the old ones.

8. Give each student an opportunity to pick up as many circles as possible of whatever shade he can find, during a five-minute period. He should put these in a large, open container, such as a quart jar, making no effort to separate them as he finds them.

9. After the five-minute period is finished, sort the circles which each student has found into small containers, according to shade.
10. Lay off one sheet of graph paper for each student in equal sections along the horizontal axis for each shade in the yellow-green-blue series, and another for the white-yellow-brown series.
11. Record on the vertical axis the number of circles of each shade that the student was able to collect over the five-minute period.

Is there a relationship between the number of circles collected and the color of the background environment? Check this visually by laying a complete series of each set of circles in a straight line on the appropriate background environment (grass or sand) and inspecting them. Are the quantitative results of the collection, and the visual results of the inspection the same? Are they what you would expect them to be? Combine the quantitative results from the entire class for the grass and for the sand. To what extent do individual differences appear among students in total number of circles collected? In relative numbers for each of the shades within a series? Can you account for any differences that appear?

What relationship do you see between this experience and the survival in nature of a species preyed upon by enemies? To what extent do you think shape was a factor? Can you think of a shape and/or size that might have worked more satisfactorily on the grass background? On the sand background? Why?

Further Considerations:

Repeat the experience. Is there any improvement through practice? Why?

Can you find any actual examples of cases in which protective coloration has worked to change a species of animal in nature over a period of time? Can you find any examples of protective coloration among plants? Can you think of any examples of protective coloration in man or the things that he makes and uses, other than the army field uniforms already referred to?

Can you explain how protective coloration furnishes an example of the interaction of variation and selection in nature to produce directional change? How important do you think protective coloration is in evolution?

*A Quantitative Study of Competition Between Species

Introduction:

Competition, either within species or between species, is a factor in natural selection. Within a species, those individuals representing hereditary strains which are able to survive and reproduce to a greater extent than others, tend to replace the others, causing the gene pool to be modified in the direction that they represent, to a point where ultimately the entire species becomes like them. This is the kind of competition that we ordinarily think of as taking place in connection with evolution. It is difficult, however, to demonstrate or measure it in a short-term laboratory experience.

Competition between species is less important on a short-term basis as a factor in evolution, although it plays a very important part on a long-term basis in determining whether or not whole species survive or become extinct. This kind of competition can be made the basis for a laboratory experience very easily, and the results can be stated quantitatively.

Materials and Equipment:

3 wooden greenhouse flats (20" x 12" x 2½")

Good garden soil of uniform quality sufficient to fill these flats. Be sure that it is moist but not wet.

Clear plastic (Saran wrap or equivalent) sufficient to cover the three flats

Garden trowel

Wooden dowel

Paper towels

Laboratory balance, preferably sensitive to 0.1 gram

Tomato seeds

Radish seeds

Procedure:

Note: This laboratory experience will require a period of six to eight weeks. In carrying it out, the entire class may be divided into teams, or a single team of two or more students may carry it out and demonstrate it

*Adapted from Biological Sciences Curriculum Study: Green Version, High School Biology, Rand McNally and Company, 1963.

to the entire class. When several teams do it, there is an advantage in that a comparison of results is possible.

1. Fill the three flats with soil to within $\frac{1}{2}$ " of the top. Firm the soil gently with your hands or with the back of the trowel.
2. On the surface of each flat, draw longitudinal furrows with the wooden dowel $\frac{1}{8}$ " deep and 2" apart.
3. In one flat, plant tomato seeds $\frac{1}{2}$ " apart in each row.
4. In the second flat, plant radish seeds $\frac{1}{2}$ " apart in each row.
5. In the third flat, plant tomato and radish seeds alternately $\frac{1}{2}$ " apart in each row.
6. Cover the seeds lightly with soil (partially fill the furrows) in all three flats. Firm the soil over the seeds gently with your hands. Sprinkly lightly with water. Be careful not to over-water or wash out the seeds. Cover with plastic and put in a warm place. As soon as the seeds have germinated, the flats should be placed in good light, and the plastic should be removed.
7. Water lightly until the seedlings have reached a point of development where heavier sprinkling will not injure them. Do not allow them to become dry. Water regularly, and be sure that all three flats are watered equally. Why?
8. If the flats are in a location such as a window sill, where all of the light comes from one side, they should be turned daily. Why?
9. At the end of 6-8 weeks, when the plants are fairly large, but before they begin to weaken and lose their uprightness, remove all of the plants, including their roots; wash the soil off the roots carefully, blot up all the moisture from the roots that you can with paper towels, and weigh the plants in the following categories:
 - a. All of the tomato plants grown in pure culture.
 - b. All of the tomato plants grown in mixed culture (x2)
 - c. All of the radish plants grown in pure culture.
 - d. All of the radish plants grown in mixed culture (x2)

Why did you need to multiply by two in the case of the plants grown in mixed culture?

Compare the total weight of the tomato plants from the pure culture with the total weight (x2) of the tomato plants from the mixed culture. Do the same with the radishes. Was there an advantage or a disadvantage from the standpoint of total weight attained in growing the tomato plants in pure culture? Was there an advantage or a disadvantage from the standpoint of

total weight attained in growing the radish plants in pure culture? Did either the tomatoes or the radishes show an advantage at the expense of the other in the mixed culture? Which one? How can you determine this?

Agriculture, as developed by the American Indians before the coming of the Europeans, was a "mixed crop" agriculture, rather than a "pure stand" agriculture of the type developed in the Old World. Maize (corn), beans of various types, and squashes or pumpkins were planted together in the same field. We learned to grow these crops from the Indians, but usually we plant them in "pure stands". Which system do you think would be the more efficient? Why?

What do we mean by competition? Try to think of situations where competition occurs between species in nature. Why do we try to eliminate weeds from our cultivated crops, gardens, and lawns? What is a "weed"?

Further Considerations:

Some types of plants, such as carrots and walnut trees, are said to produce and release unto the soil substances which prevent certain other plants from growing near their roots. Do you think that anything of this kind might be taking place in the case of the radishes and tomatoes?

How is this type of relationship related to the discovery of antibiotics produced by certain molds and bacteria? What is an antibiotic? What function do antibiotics serve in nature for the organisms that produce them? How is this function related to their function when used as medicines? How is all of this related to competition? To survival?

When antibiotics are used as medicines, the organisms that cause the diseases that they are used to treat, sometimes respond by developing mutant strains that are resistant to the antibiotic. Do you think it possible that something like this may occur in nature? What would happen if it did? How is this related to evolution?

In a free society, we have many people in the same business or profession who are competing with one another (grocerymen, salesmen of office equipment, building contractors, physicians, lawyers). The system seems to work very well. In other professions (teachers, priests or ministers, scientific researchers) competition is regulated, reduced, or absent. This also seems to work very well. Why? Which system do you think works better? Would a society in which competition was eliminated as far as possible work better or less well? Why or why not?

Would it be possible to eliminate all competition? Would any evolution occur, either in the natural world or in human society, if all competition were eliminated?

A Mental Experience, Directional Change in the Human Species: The Long Line

Introduction:

There is an increasing accumulation of evidence which indicates that the human species may be around 2,000,000 years old. Recent discoveries of early human and near-human fossils in Olduvai Gorge in East Africa have been determined to be 1,750,000 years old by the potassium-argon method of chemical dating. Others from the same site lie in still deeper and older rock layers. Still more ancient finds of pre-human fossils, also from East Africa, go back 25,000,000 to 30,000,000 years.

Man belongs to a group of mammals called primates. These all have teeth that are somewhat like man's, hands and sometimes feet that are capable of grasping and holding objects, nails instead of claws, and brains that are proportionally larger than those of other mammals. Many of them show some tendency toward the upright posture, like man's. This group includes, along with man and various forms of fossil man and pre-man, the anthropoid apes (chimpanzees, gorillas, orangutans, gibbons), baboons, tailless Old World monkeys, tailed New World monkeys, and a couple of generally unfamiliar forms called lemurs and tarsiers.

All of these animals have many genes in common with man. One study of the extent of the common anatomical characteristics possessed by man and the anthropoids that are closest to him indicates that he shares:*

385 characteristics with the gorilla
369 with the chimpanzee
354 with the orangutan
117 with the gibbon
Only 312 are exclusively man's own

This would indicate that the gene pools of humans, gorillas, chimpanzees, orangutans and gibbons are the same or similar to the extent that characteristics are shared. How do you think that man would compare in terms of shared characteristics (and the genes that determine them) with a cat? A horse? A lizard? A fish? An insect? You can think of relationships with members of your own family in terms of shared characteristics (and genes). You can think of relationships between the gene pools of different species in this way, also.

Ultimately the modern gene pools of man and the anthropoids were all derived from a single ancestral gene pool. The modern ones have diverged from the ancestral one through the operation of mutation and natural selection. It has taken 30,000,000 years and more to produce this divergence. The possessor of the ancestral gene pool that lived 30,000,000 years ago was neither human nor anthropoid, although undoubtedly it showed many of the characteristics of both of its modern descendents.

There are generally about three or four human generations per century in any family line. A boy born in 1964 has a father born in 1936, a paternal

*Quoted from von Koenigswald, G. H. R., The Evolution of Man, the University of Michigan Press, Ann Arbor, Michigan, 1962.

grandfather born in 1908, a great-grandfather born in 1877, a great-great-grandfather born in 1839, a great-great-great-grandfather born in 1805, and a great-great-great-great-grandfather born in 1775. This means that there are about 35 generations per 1,000 years, 350 per 10,000 years, 3500 per 100,000 years, and 35,000 per 1,000,000 years. Thus, there have been about 70,000 human generations since man became man around 2,000,000 years ago.

Present-day races of man, along with all of their sub-races and mixtures, belong to a single, highly variable species, Homo sapiens. Representatives of an earlier species of man, Homo erectus, have been found in fossil form in various parts of the Old World. Recently L.S.B. Leakey*, a British anthropologist, working in East Africa with the support of the National Geographic Society, has discovered what he believes to be the remains of a still earlier species of man, Homo habilis, in Olduvai Gorge. Representatives of the group of primates which immediately preceded man, the Australopithecines, have been discovered in East and South Africa. These are from 1,000,000 to 3,000,000 years old. An earlier pre-human form, called Kenyapithecus, about 13,000,000 years old, also comes from East Africa. Other early relatives of man have been found in various parts of the Old World, but the line seems clearest in Africa.

Many anthropologists believe that each species of man has developed directly out of the species which preceded it. It appears possible to trace a definite line of descent backward from modern Homo sapiens, through Homo erectus, probably through Homo habilis (if Leakey's interpretation of his most recent find is correct), to the Australopithecines, and beyond.

While we cannot ride a time machine backward along our line of descent, we can travel along it in our minds, "seeing" the individuals in it with our imagination, based on the best evidence that we have as to what they looked like. This is a laboratory experience which is almost entirely mental. In it we will attempt to follow the "long line."

*You may wish to read the following readily available accounts of Leakey's work:

See the National Geographic Magazine:

Leakey, L.S.B., "Finding the World's Earliest Man", Vol. 118
(No. 3) pp. 420-435, September, 1960.

"Exploring 1,750,000 Years into Man's Past", Vol. 120
(No. 4) pp. 554-589, October, 1961.

Curtis, Garniss H., "A Clock for the Ages: Potassium-Argon",
Vol. 120 (No. 4) pp. 590-592, October, 1961.

Payne, Melvin M., "Family in Search of Prehistoric Man", Vol. 127
(No. 2) pp. 194-231, February, 1965.

Equipment:

- A little knowledge of man's past
- A keen curiosity
- An active imagination

Procedure:

It is most interesting to do this with a fairly large group, such as a class of around 30 individuals.

1. As a preparation for it you should try to find and examine carefully pictures of your parents when they were younger, your grandparents when they were about the same age, and, if possible, your great-grandparents and any still earlier ancestors. You should also examine pictures and restorations, showing how primitive man, earlier forms of man, and pre-human types are believed to have looked. Any familiarity which you have with man's past through a study of history will be helpful.
2. Now, if you are a girl, think of yourself as being the latest of a continuous line of women: Your mother, her mother before her, and so on back, an unbroken line of females extending backward to the beginning, whatever and whenever that was.
3. If you are a boy, think of yourself similarly as being the latest of a continuous line of males: your father, your paternal grandfather, his father before him, and so on back, an unbroken line of males extending backward to the beginning, whatever and whenever that was..
4. Think of the individuals in the line as all about the same age, about the age of your parents as you know them now or a little younger.
5. Now detach yourself from the head of the line and walk backward, observing each person in the line closely as you do so. Remember that you are seeing about three or four generations in 100 years. By the time you have looked at 35 people you will have traversed 1,000 years. By the time you have seen 70 you will be about at the beginning of the Christian Era in Roman times. With 100 generations you will be seeing your line as it appeared at about the time of Kings David and Solomon in the Bible (about 900-1,000 B.C.).

One hundred thirty-five generations will put you at about the time in the Bible when Abraham left the city of Ur of the Chaldees (around 2,000 B.C.). This city has been re-discovered and excavated by modern archeologists. It was already an old city when Abraham lived in it.

Try to tie in other points in your line with periods of history that you know about or can look up. Your ancestors may not have been living in the places where the things that you know about were happening, but they were living somewhere at the same time.

What about the period of the Egyptian and Babylonian civilizations? What about the time of the building of the earliest cities? Of the domestication of plants and animals, and the invention of agriculture?

6. As you travel back along the line, observe the general appearance of the people, degree of cleanliness, clothing, hair style, any ornaments they wear, any tools that they have, any utensils that they use. A visit to a museum may help with this.

Remember that tools, utensils, clothing, devices of all kinds, even ornaments, evolve in much the same way that living organisms do, but do so much more rapidly. What kind of food do you suppose your ancestors ate? What kind of language do you suppose they spoke? Do you think you could have understood them? Does evolution work in these areas also?

7. You will grow tired walking. At about the point where you now are, small motorized vehicles can be provided. You may ride one if you wish. After all, seeing individuals at this point and beyond is less important than getting an idea of the changes that take place in the line over fairly long periods.

8. Ride backward. What do you think you will be seeing in 10,000 years? Remember that this is only 350 generations behind the point where you left your parents. In 100,000 years? This is 3,500 generations. In 1,000,000 years (35,000 generations)?

9. In going backward 1,000,000 years and more, you will pass progressively from Homo sapiens into Homo erectus, and from this into Homo habilis and finally into Australopithecine. Ultimately, maybe around 70,000 generations from where you started, you will realize suddenly: "Why these creatures aren't human! When did this happen?"

At this point you may turn your vehicle around and retrace the latest portion of your route slowly. Do you think that you will find an answer to your question? Do you think you will find a place where you can say: "This woman (or this man) is human, but her mother (or his father) is not?"

10. Science, generally, has not found sharp boundary lines in nature. Related classes of natural phenomena generally have been found to grade into one another imperceptibly in the areas where they meet. Variation tends to be continuous, both within species and between related species. This is true both in our present-day world and backward in time. Can you find examples of this kind of gradient other than the one that we have discovered in the case of man? Can you think of examples from everyday experience? Where would you draw a line between tall and short boys (or girls)? Between good students and poor students? Between hot and cold days? Think of other examples. Are there clear dividing lines between light-skinned and dark-skinned peoples in the Old World? To what extent is it different in the New World? Why?

Further Considerations:

What do you think, at this point, about the once widely-held idea that certain races of man are "higher" or "better" than others? Have you found any reinforcement for the idea that "all men are brothers"? What do you think would be the extent of overlap between the genes possessed by individuals belonging to different present-day human races? How do you think this would compare with the extent of overlap between the genes possessed by individuals having the same parents? Consider these questions in the light of the comparison made earlier between the human gene pool and the gene pools of the gorilla, chimpanzee and orangutan. Do you find any basis for the popular notion that "evolution teaches that man came from a monkey"?

What do you think you would find if you were to continue to follow your "long line"?

Extensions of Man's Body: How They Have Evolved

Introduction:

With his development of the upright posture man began an entirely new kind of evolution. Because his upright position left his hands free for grasping, he began to use tools. He adjusted to his environment and attempted to solve the problems that it presented by evolving tools, rather than by changing his body form. This has constituted a kind of substitute evolution, or evolution by proxy.

Thus, instead of changing himself into a highly specialized running animal like the horse, he invented and evolved machines to do his rapid traveling (locomotive, automobile, bicycle and motorcycle). Similarly, instead of evolving, like the seal or walrus, into a highly specialized swimming animal, he invented and evolved various kinds of boats and ships to do most of his swimming. He evolved weapons instead of specializing his teeth and claws for defending himself, fighting and killing prey. He evolved airplanes to do his flying, bulldozers to do his digging, and even complex machines to do some of his remembering, calculating and thinking. The movement toward automation is a development of our time. Self-repairing machines may well be a development of the future.

We have evolved a bewildering variety of tools for dealing with the problems presented by our environment. Here, of course, we are using the word "tool" in a much broader sense than usual. A tool is anything which is useful in solving a problem. The evolution of man's physical tools may well have begun when he first picked up a club or a stone to ward off an attack by another animal or an angry neighbor. He was using a tool to solve a problem presented by his living environment. This might well involve his survival.

There are many other examples of tools used to solve environmental problems. If it is raining you wear a raincoat to solve a problem of environmental adjustment. Your ancestors did not evolve a coating of coarse hair to shed the rain as some other animals did. They invented clothing (including raincoats) instead. You wish to get an idea across to another person. Getting it across constitutes a problem. You use written or spoken language as a tool to deal with this problem, possibly devising new word combinations or even inventing new words to adapt the tool to the need.

Social, political and economic systems are tools which we have evolved for dealing with problems of commodities, media of exchange, distribution of goods, and standards of living. Money and commodities themselves are tools for meeting human needs. Ideas are tools for solving problems in human thinking. These ideas affect our actions.

The words that you have just read have been used in a particular combination as tools for expressing the idea that man has extended his physical body and its capabilities in many ways to adjust to his environment. The bodies of other animals have undergone structural changes in becoming specialized to deal with a particular kind of life. Later, because of their specialization, they have found themselves unable to live at all except in a special habitat: the sea, the freshwater of ponds and lakes, open plains, forests, the tropics, the arctic.

Man's body, on the other hand, has remained relatively unspecialized. By evolving and using tools, in the broad sense that we have used the word, he has been able to adjust even better to the same problems to which other animals have adjusted. He has also adjusted to many other problems. It is because of this that man has become dominant over the whole earth, and soon, possibly, over other worlds also.

Resources for the Problem

No special equipment or materials are necessary for this laboratory experience. A number of different kinds of resources, however, will prove useful. These include backfiles of magazines, especially the National Geographic Magazine. Nearly any library will have some of these. Sometimes complete or nearly complete files, going back fifty years or so, have been kept. Old newspapers, books on history, any books which describe or picture the ways in which people lived, and the things that they used before our time, will be helpful. We are living in a period of rapid change, and it will surprise you how shortly before our time conditions differed greatly from the present.

If a museum is available near where you are, it will furnish an excellent resource for study. Antique shops are full of things that people formerly used: old furniture, old dishes, old utensils, old tools, sometimes old books. Many people collect these things. Your parents or your friends' parents may have some of them. Old snapshots and collections of family portraits are useful in some cases. Conversation with older people, your grandparents or others their age, is a good resource.

A part of your problem is to locate appropriate material. It is necessary to learn how to look for it. This is a good opportunity to learn about the community where you live, and the things and people in it. You should make the most of this opportunity. Any community has a great deal of material which will be useful for this study. A rural community is in some ways more advantageous than an urban community, and vice versa. The resources available in one are different from those in the other. No two communities, even of the same type, are alike in this respect. You will find your study very interesting.

Procedure:

This study may be carried on in the form of individual, out-of-class projects, or by field trips which may be arranged to suitable places. Probably, in most cases, a combination of these two approaches will prove best. It may be desirable for different students or groups to work on different aspects of the study, and then bring their results together for the benefit of the class.

Evolution of the Automobile

The automobile began in the 1890's with a combination of some features taken from the bicycle and some from the carriage, together with a motor for propulsion. The motor was originally placed beneath the car, but was very quickly moved to the front, possibly because this was where the horse had been.. There have been various experiments with rear-end drives.

These have generally proven more successful in Europe than America. The German Volkswagen is a notable example. Can you think of any others? The automobile has steadily evolved during the past two-thirds of a century toward a form that is uniquely its own, yet which still shows some evidence of its origin.

The National Geographic Magazine began publication in 1889. It has carried advertisements which pictured automobiles since the early years of this century. These advertisements constitute an excellent source for tracing the evolution of the automobile. Study these or any other available source. What changes can you observe in the external appearance of the automobile? Can you identify any trends? When did they first appear? What kinds of cars were sold at the time of World War I that are no longer on the market? Were the present kinds available then? What new ones have appeared? Were these really new or were they variant forms of older ones? How does the number of companies making cars compare with the number at the time of World War I? What has happened? Why?

Of course the external appearance of cars tells little or nothing about internal changes. Talk with an older person who has driven cars for most of his life, and ask him to recall what some of these internal changes have been. How about number of cylinders? What about gear shift? What about method of starting the motor? Any others? What about accessories? Is it possible to discover any trends? Try to account for these changes in terms of the environment in which the automobile has operated in the past half century or longer (roads, growth of population, growth of cities, general improvement of standard of living). What about ever-all size of cars? Compare automobiles used in America and in Europe in this regard, and try to account for any differences that you find. What about cost of gasoline? Has the quality of gasoline improved? Have cars become more efficient in their use of gasoline? What about tires? What about driving speed? What about cost of cars?

How has increased use of the automobile affected the geography of our cities? What about the future? What problems must we face in connection with increased use of the automobile? See if you can find out what is the present thinking of the automobile manufacturers with regard to new developments in motor and body design.

Try to account for the changes which have occurred in the evolution of the automobile in terms of natural selection. This is survival of that which works, and elimination of that which works less well. What are the selective factors that have operated in the evolution of the automobile?

Evolution of the Airplane

The airplane began through experimentation with man-lifting kites and studies of the flight of birds. The first airplanes were essentially man-lifting kites with motors for propulsion. How does an airplane stay in the air? What is Bernoulli's Principle? Can you think of any common examples of its operation that you have observed?

With the attainment of greater speeds, the airplane has evolved steadily in the direction of becoming a projectile, manned or unmanned. How is this evident in its external appearance? What have changes in the kinds of motors used for propulsion had to do with this? What kinds of motors are now available for propulsion? The intercontinental ballistics missile and the development of space ships constitute the ultimate in this line of development. What means of propulsion and structural designs are possible for use outside the earth's atmosphere in interplanetary space? Why?

Following the same general lines of investigation as have been indicated for the evolution of the automobile, study the evolution of the airplane. Here old magazines will give you less help. On the other hand, more material on present and possible future developments will be available in current and recent newspapers and magazines. Also you will find more material in books and in textbooks. Again talk with older people who remember some of the stages in the evolution of the airplane.

How have airports evolved along with airplanes? What about spaceports? What effect has the military use of aircraft had on the evolution of the airplane? What about the increase in air travel by civilians? How has this affected the use of other means of transportation? Has the use of the automobile also entered into this picture? What have been the selective factors that entered into the evolution of the airplane? Have they been the same as those that have operated in the case of the automobile? If so, why? If not, why?

Evolution of Language

New words are constantly appearing. Sometimes they survive, but more often they do not. In some cases, however, whole new vocabularies replace old ones. When man's activities change, and the things that he does give way to others, new words become necessary, and old words become obsolete. This happened when the automobile, truck and tractor replaced horses and horsedrawn equipment. The very words "truck" and "tractor" themselves were new or acquired new meanings. A "truck" formerly meant a small handpushed carrier for luggage. The word "tractor" is entirely new. What is the derivation of the word "automobile?" A generation ago radio, and more recently television, brought new words into the language. Language evolution is, in general, related to people's need for expression in situations of actual living. When the situations and relationships change, language changes with them. At some periods and in some places, the change is rapid. At other times and in other places it occurs slowly or not at all. It is in this way, however, that the languages that we have in the world today have developed and differentiated from one another. Anthropologists estimate that it takes about 20,000 years for two languages which have a common ancestor to become completely separate.

There are books on the development of language differences which are non-technical and interesting. Look for some of these in your local library. Occasional articles in newspapers can be found dealing with these topics. Your best resource, however, at least to begin your study, is your own experience. Observe differences in speech among people from different parts of the country, between rural people and city people, between older people and younger people. What differences can you discover? What is dialect? What dialects can you detect? Dialects differ in different sections of the country, sometimes even in different cities. Sometimes such differences can be detected on television, watch for them.

Talk to your parents and other older people and with their help try to identify words like "radio", "television", "nylon", "paperback" that have come into existence in recent memory. You can easily compile long lists of these. Some you will be able to think of from your own experience. Others, like "refrigerator" are more than a generation old. Try to find out what brought them into existence. Some are manufactured words (like "rayon", "penicillin"); some are even commercial brand names (like "scotch-tape", "kleenex", "band-aid") that have come to mean a kind of product, rather than simply the brand of that product made by a particular manufacturer. Other manufacturers of the same product may not like this. What effect do you think it might have on sales?

Identify slang words and terms current among your friends. These change rapidly, often in a single year. Few of them survive. Ask your parents about slang terms that were current when they were young. Have any of these survived? Do your parents still use any of them? Do you? Have your parents or teachers taken up the use of any of your slang terms? To a large extent slang belongs to the language of young people.

When the same language is spoken in widely separated countries, it may evolve differently, using different words for the same new development when it arises. In England and the United States this has happened. What words are used in England that correspond to our "radio", "truck", "gasoline", "hood" (of a car), "trailer", "elevator"? Can you find others that differ?

See if you can find a list of words pertaining to horses and horse-drawn vehicles, which formerly were in general use, but now are limited to hobby groups and others who still use horses. How might you go about investigating this?

Evolution of Clothing

The evolution of clothing has shown long-time trends related to availability of materials and the activities in which people engage. Thus, the introduction of cotton into the Mediterranean world in ancient times, and the availability of silk following the development of trade with the Far East at the close of medieval times, made possible changes in certain types of clothing. The development of various kinds of synthetic fabrics in our own time has produced even wider effects.

The replacement of natural dyes by synthetic ones, which followed the discovery of the first aniline dye by the English chemist Perkin in 1858 has resulted in the use of a far greater variety of colors and shades, and the availability of brighter and more permanent colors. How is this comparable to what is happening now in the case of fabrics? Can you think of other similar examples?

One field of cultural evolution reacts upon another. There are complex interrelationships among different aspects of people's adjustment to the problems of their environment. In ancient times in the Mediterranean lands, workers went naked or nearly so, while women and non-working classes of men wore long, flowing costumes. With the spread of Christianity and acceptance of its concepts of modesty, working people came to wear clothing, more or less close-fitting, as befitted their active life. Women and

non-workers continued to wear clothing of long, flowing type. What happened in Polynesia with regard to clothing when missionaries introduced Christianity? What about clothing among primitive tribes at the present time? To what extent do men and women all over the civilized world wear the same kinds of clothing now? Why? How does this compare with conditions fifty years ago? Why?

In western countries, during medieval times, men of the working classes came generally to wear trousers, but the men of the non-working classes, prior to the political revolutions of the late 1700's, wore knee breeches with elaborate coats, collars, stockings and shoes. Following the French and American Revolutions, the long trousers of the working classes were adopted by all men. Why do you think this happened? Study pictures in books on the history of Europe and America, and see if you can determine just when this change occurred.

Women continued to wear long, flowing clothing generally until World War I. What changes took place in women's clothing in the decade following World War I? Why do you think these changes occurred? When did the custom of women wearing slacks develop? Why?

What has happened to the heavy winter underwear that both men and women used to wear? Why? What has happened in the case of outdoor clothing for winter? Why? How have bathing costumes for both men and women evolved during the past seventy-five years? Why?

Study clothing evolution during the past hundred years. What specific changes have occurred in women's clothing? In men's? Which has shown the more rapid changes? Why do you think this is so? Long-term evolution should not be confused with fashion change, but the same trend may reappear in succeeding fashion cycles. What influence do you think fashion has? Temporary? Permanent? Do you think that long dresses for women for day-time wear will ever come back? For an extended period of time? Why?

You will find family portraits and other pictures of people long ago the best available source for a study of clothing evolution. Beginning about the time of World War I, with the invention of the small, portable camera the making of "snapshots" became common. What about the word "kodak"? Examine snapshot collections in your own family and those of your friends. These may include as many as three generations. Pictures of people in advertisements in old magazines are a good source if they are available. Talk to your parents, grandparents and other older people. Most museums contain old costumes. Note the colors of these as well as the costumes themselves. How are they different? Is this due entirely to their age?

Further Investigations:

In any kind of evolution there is the phenomenon of old, primitive or ancestral types persisting in out-of-the-way places which are marginal or isolated. In these places the environmental conditions have not changed, competition is not great, and the stream of development has passed them by. Students of biological evolution call these primitive types "archaic", and the places in which they survive "relict" areas. Such places are found in deep lakes of ancient origin, mountainous areas, the depths of tropical swamp forests, desert areas, islands in the sea, the extreme edges of continents, and isolated peninsulas off larger land masses. The archaic species of plants and animals found in such places are the "living fossils" of popular journalism. What are some examples?

In the area of proxy evolution such "living fossils" can be discovered in any of the classes of tools that man uses. They are found in any conservative situation where, for one reason or another, the stream of living has passed them by. The necessity for change to meet new situations and problems has not been sufficient to cause them to be abandoned. They are more likely to survive in rural areas than in cities, in hilly or mountainous areas than in plains areas, and in poor soil areas than in good soil areas.

"Language islands" and conservative religious groups preserve antiquated forms of dress, language and other cultural devices. Ceremonies and traditional festivals, such as are carried on in some European communities and Indian tribes, fall into the category of relict areas which preserve antiquated forms, especially of dress. Can you think of any others? What about weddings? Can you think of any cases where these antiquated customs have been artificially perpetuated or revived as tourist attractions? Kerosene lamps and horse-and-buggy transportation have been retained longest in hilly or mountainous, poor-soil areas. Older people are the ones most likely to cling to "old-fashioned" things and forms of speech and dress. Why? Horse-drawn farm implements have survived similarly. Old models of automobiles in everyday use disappear last in poor, rural, hill districts.

If a museum is available, look in it for old methods of lighting, old forms of transportation, old farm implements, old types of dishes, glass-ware, furniture, hand tools, and other old things. The Henry Ford Museum and Greenfield Village at Dearborn, Michigan, have an excellent collection of these things. The Museum of Science and Industry in Chicago has some of them. Almost any historical museum will have at least a few of them.

Antique shops are filled with some kinds of old things. Ask your parents if they know of people who have private collections of some of them. Try to find and study some of these things. Can you identify any trends in their evolution? What kinds of forces and influences do you think shaped their development? See if you can discover or figure out answers to some of these questions.

The isolated, mountainous, poor-soil districts of the South preserve many of the language forms of Middle English. This is the English language of the time of Queen Elizabeth I, the King James version of the Bible, and Shakespeare. Many of the medieval ballads which have long since disappeared

in England have been found in the southern mountains, which began to be settled when Middle English was still being spoken, and the ballads were still being sung in the home country. Have you ever heard any of these songs? Listen to some of them in a record collection. If you know any people who come from these areas, listen for differences in their speech. What are some of the differences?

Ancient language forms also persist in the rituals of churches. Since religions tend to be conservative, these are comparable to the survival of other archaic forms. Such church languages are called ecclesiastical languages. The use of Latin as an ecclesiastical language in the Roman Catholic church is well known. Nearly all religions show some phenomena of this kind. What other specific examples can you discover?

Religions may also preserve old clothing types. The clothing worn by Roman Catholic monks and nuns falls in this category. What other examples can you think of? Generally both language forms and clothing forms tend to preserve the types that were in use at the time the religion was founded or the particular custom originated. What about Salvation Army uniforms? To what military uniforms are they related? Why?

How is the evolution of man's machines, language, clothing, other cultural forms and ideas--tools in the broad sense for dealing with problems posed by his environment--comparable to the evolution of plants and animals during the earth's long history? In what ways is it similar? In what ways different? What examples of this kind of evolution can you think of other than the ones suggested here? To what extent are all forms of evolution related?

X

B. Scientists think in terms of relationships rather than absolutes:

1. Idea of measurement as an expression of relationship
2. Idea of templates or transference of pattern
3. Idea of interdependence and interrelationship
4. Idea of the necessary interaction of heredity and environment
5. Idea of differential rates of processes in development
6. Idea of tools, machines, and outside sources of energy as extensions of man's body and its capabilities

Idea of Measurement as an Expression of
Relationship

1. Idea-Bridge: "Thinking About Measurement as an Expression of Relationship"
2. Laboratory Experiences:
 - *a. "A Study in Measurement"
 - *b. "Measurement as an Expression of Relationship: A Simple Balance"
 - *c. "Measurement of a Relationship: Depth in Relation to Pressure"
 - *d. "Volume, Weight, Pressure, and Physical State"

*Included in Bulletin No. 313, NDEA Title III, Open-Ended Laboratory-Centered Science for Grades 7-8-9. Michigan Department of Public Instruction, Lansing, Michigan, 1965.

Thinking About Measurement as an Expression
of Relationship

How do you measure anything? You do it by comparing the thing you want to measure to something else. Let's take the measurement of time as an example.

"That all took place within the lifetime of a single individual." You are comparing the time it took for something to occur to the length of the human life cycle. Many common time measurements are based on the length of cycles of one sort or another. Time is a steady flow, without beginning and without end, so far as we are concerned. So we break up time spans that are significant to us into convenient and easily understandable units.

The American Indians and many other primitive peoples measured time in "moons", or lunar cycles, based on the easily observable phases of the moon. Our word "month" comes from this. A lunar cycle is 28 days long, from the new moon until the dark of the moon. The old Hebrews in the early Biblical period did the same thing. Their year was a lunar month. There are 13 lunar months (28 days each) in a year. In the early chapters of the Book of Genesis men were said to live for hundreds of years. Methuselah lived to be 965 years old. Try dividing this and the ages given for others of the ancient patriarchs by 13.

Our day is a cycle, the time it takes for the earth to make a complete turn on its axis. Our year is an annual cycle, the cycle of the seasons, the time it takes for the earth to make one complete circuit of the sun. The day, year, and 28-day month are natural divisions of time. The minute, hour, week, and 28 to 31 day month are man-made divisions of time.

What other ways do we have for measuring time? A clock is a mechanical device for measuring time in terms of cycles and divisions of cycles (hours, minutes, seconds). We also use multiples of cycles (weeks, centuries, millennia).

We measure other things similarly by comparing them with something else. Thus we measure the length, breadth, thickness and weight of material objects; we measure volume; we measure land areas and distances; we measure temperature, pressure, light, color, sound, wind movement, and a great many other things. We say that we quantify data; we deal with quantities. To do this we have to make measurements. All of science depends on measurement. Galileo said, "Science attempts to measure all things, and to reduce all things to measure."

All kinds of odd things have been used in making measurements: the length of a king's foot, the width of a hand, the weight of a stone, the length of a man's step, a fraction of the distance from the earth's equator to the north pole, the distance that light can travel in a year, the density of water, the length of the light waves produced by the atoms of a particular element when heated to a standard temperature, the time that it takes for half of the mass of a radioactive chemical element to decay.

As man has increased his knowledge and become more sophisticated, the kind of things that he has needed to measure have become more varied and complex, and the units of measurement which he has devised to quantify them have likewise become more sophisticated, varied, and complex. Primitive man had no need for dealing with light-years or the half-lives of radioactive elements. He had no need for measuring electric current, or light, or even temperature. He did not know that radioactive elements existed. A light was bright or dim. A day was hot or pleasant or cold. And when things did need measuring, such as land areas, or weights of grain, or volumes of wine, units such as the length of the king's foot, or the length of a step, or the weight of a certain size of stone, or the amount of liquid that would fill a pig's skin served well enough.

Increased need and wider use brought the necessity of standardization, and finally a simple system with standard relationships between units of different types (the metric system) was developed and has gradually been replacing the old units.

The idea of measurement, however, has not changed. It is still a matter of comparing the thing to be measured with something else.

A Study in Measurement

Introduction:

Most people think of units of measurement as being definite and important in themselves. Actually measurement is relative. Something is compared to something else. Furthermore the importance of units of measurement of different sizes is relative to the size of the thing being measured or to the size and importance of the problem.

Materials and Equipment:

Rule marked in metric units
Foot rule
50-foot or 100-foot carpenter's tape
Compound microscope and micrometer ocular
Infusion culture containing paramecia or other relatively large ciliate protozoa.

Procedure:

Using appropriate measuring equipment, measure the following dimensions of:

A piece of typing paper (length and width)
A dime (diameter)
Your body (height)
Your classroom (length and width)
Your school ground (length and width)
A paramecium or other large ciliate protozoan (length)

Note: It may be necessary for you to learn to use the microscope in order to do this. Do not attempt it without receiving specific instructions from your teacher.

In measuring the sheet of typing paper, use both the metric rule and the foot rule. Work out a method of converting inches to millimeters and centimeters. Expand this so that you can convert feet to meters. Work this out rather than "looking it up" in a book. What is a micron?

Now convert all of your measurements (1) to millimeters, (2) to microns. How accurate do you think these figures are for the dime? The sheet of typing paper? Your height? The classroom? The school ground? On what did you base your decisions? How accurate is it necessary for the figures to be? Why? Is there a relationship between the necessary degree of accuracy and the use of measurement units of a progressively increasing order of size?

Further Ideas:

How important is it that you know about the 50 cents if (a) you have only \$1.50 when you are ordering dinner at a restaurant? (b) If you have \$51.50 in your checking account at the bank when you wish to buy an article of clothing? (c) If you have \$5,151.50 in your savings account when you wish to make a down payment on a house? (d) If a proposed large expenditure by the company for which you work is \$55,151.50? (e) If an inter-continental ballistic missile costs \$5,151,151,151.50? Why?

Measurement As An Expression of Relationship:

A Simple Balance

Introduction:

We are so accustomed to using units of measurement: inches, feet, yards, pounds, quarts, gallons, or millimeters, centimeters, meters, grams, kilograms and liters, that we tend to think of these units as things that have an existence of their own. They are a part of our thinking, just as words for physical objects are. We also tend to think of them as "tools", as a means to the end of quantitative expression. They certainly fulfil this function, but they are actually more than this. They are expressions of relationship between two quantities, one of which is stated in standardized terms. This is the idea of measurement which underlies the making and use of measurements.

Actually units of measurement are man-made, with an arbitrarily set value. A foot was the length of the foot of an English king. A yard was the length of the arm of another king. The British and American gallons are not the same. The height of horses was formerly measured in units called "hands". An old English unit of weight was called a "stone."

The metric system was worked out logically at the time of the French Revolution. The meter was set as one ten-millionth part of the distance from the equator to the north pole of the earth.* All other quantitative measurements were based on it, worked out in multiples of ten. The only reason that we use "tens", however, is that we have ten fingers. The ancient Babylonians used "twelves", and the Mayas "twenties" (ten fingers and ten toes.) Modern electronic calculators use a numbering system based on "twos", since only two alternatives are possible in any particular case.

It is possible to set up a system of measurement of your own. To do so will help you to think of measurement as a standardized but artificially-based expression of a set of relationships. When you have done this you can translate your system into standard units.

Materials and Equipment:

Yardstick (new, clean, and as free of knots or grain as possible)
Triangular file
Frozen fruit juice cans, with tops removed
Soft wire
BB shot
Pennies
String
Set of gram weights
Support for suspension of balance

*Because of difficulties in getting an accurate measurement of this geographic distance, the metric system is now based by international agreement on the length of the waves of light produced by a particular type of atom of the gas krypton, when those atoms are heated.

Procedure:

1. Using the file, make a notch across the top of the yardstick at its exact midpoint. The notch should be deep enough to hold the string. Using a piece of string about six inches long, tie it around the stick with the knot lying in the notch, leaving the two ends of even length. Tie the ends of the string together, and hang the stick from the support. Does it balance, or is one end higher than the other?

2. With the file, make shallow notches across the top of the stick at each quarter-inch mark, from the midpoint to the end of each side. Be careful to make the notches straight across the top of the stick, as uniform in depth as possible, and each one exactly on the quarter-inch mark. Suspend the stick again. Is it as well balanced as before? If it isn't, what do you think has happened?

3. Punch a small hole on each side of two fruit juice cans, just beneath the rim at the top of the can. Cut two pieces of wire of equal length. Pass a piece of wire through the holes in each can. Tie the ends together in such a way that the can may be suspended from the stick, and moved along from one notch to another.

4. Suspend the cans from the last notch at each end of the stick. Do they balance? Reverse them. Do they work as well, regardless of the end from which they are suspended? Either the stick or the cans or both may not be completely balanced. Select one can for the right side and one for the left side, and mark them, so that you can use them this way from this point on. Add BBs to the can on the side that hangs highest, to bring it into balance. Write down the number of BBs used, and leave them in the can. They constitute the necessary correction factor at this point.

5. Add 50 BBs to each can. Are they still in balance? Is the correction factor still valid? If not, can you suggest a reason why? Test your hypothesis, if you can think of a way of doing so. In any case, adjust your correction factor, if necessary, by adding or subtracting one or more BBs, and proceed. Be sure to keep a record of what you have done.

6. Move both of the cans containing the BBs toward the center, one quarter-inch at a time. Bring them as close together as you are able without the cans touching. Are additional corrections necessary as you proceed? Add or subtract BBs as necessary, keeping a record of the number of BBs and the points where any changes are made. If adjustments are necessary, can you suggest a reason why? Test your hypothesis if you can devise a way of doing so.

7. Remove all BBs from the cans, and balance the cans at a point three inches (12 quarter inches) from the mid-point. Add BBs to serve as a correction factor to the extent necessary. Is the correction factor at this point, using the empty cans, what you would have predicted it to be? If not, can you suggest a reason why? Test your hypothesis if you can. In any case, proceed, using the necessary correction factor.

8. Place a penny in the left-hand can. Add BBs to the right-hand can to balance the penny. How many BBs does it require? Add a second penny on the left-hand side, and move the right-hand can out from the center one quarter-inch. Add BBs as necessary to achieve a balance. Record the data. Continue to add pennies one at a time, moving the right hand can out from the center one quarter-inch with the addition of each penny, and adding BBs each time as necessary to achieve a balance. Continue to record the data.

9. You are now weighing the pennies, using "quarter-inches" and "fractions of quarter-inches" as weight units. The fractions are expressed in terms of BBs. Thus a penny may weight "one quarter-inch and two BBs." Is the weight of each additional penny the same, as you move from near the center toward the right end of the stick? If there are differences, are they consistent as you move along? Is there a trend? Determine the average. Try to account for what you find. Test your hypothesis if you can think of a way to do so. Try beginning farther from the center. Do the ages and relative wear of the pennies make any difference? Think of other ideas to test.

10. Now determine the value of a "quarter-inch" in terms of BBs. Start with empty cans at the twelfth notch (three inches) from the center on each side. Balance the cans again, using whatever correction factor is necessary. Put 50 BBs in each can to start. Move the right-hand can out one quarter-inch at a time, and add BBs to the left-hand can as necessary to maintain a balance. Record the number of BBs added to balance each additional quarter-inch the right-hand can is moved. Is the number the same each time? Is there a trend? Determine the average. Are your results consistent with those that you obtained with the pennies? If not, suggest a possible explanation. Test your hypothesis if you can devise a way of doing so. It might be a good idea at this point to replicate the entire experience, using new materials throughout, to see if the results are the same or comparable.

Further Considerations:

Both equal arm and unequal arm balances can be used to weigh quantities. Ordinary laboratory balances are equal arm balances. Unequal arm balances were formerly in use on farms and elsewhere for weighing sacks of grain and other quantities. They were called "steelyards."

What would you say as to the margin of error in your balance. Work out the equivalence of the quarter-inch unit on your balance in grams. Number the notches on each end of the stick. Start with the first notch at each side of the center notch as "1", and number toward each end. Weigh various objects with your balance. Check the accuracy of the figures obtained by weighing the same objects on a laboratory balance. Explain the operation of your balance in terms of a lever.

How does a spring type scale work? Which do you think would be more likely to develop inaccuracies, a spring type scale or a balance type? Why?

What are the relationships between weight, mass and density? What is meant by specific gravity? What standard is used for expressing it? How is it possible to calculate the weight of the earth? On what basis is the statement made that the moon has a lower density than the earth? What determines the force of gravity? Why would a man weigh less on the moon's surface than on the earth? What about Mars?

*Measurement of a Relationship: Depth in Relation to Pressure

Introduction:

The physical factors of the environment which affect our lives and those of other living organisms are related to one another. In some cases this relationship is difficult to demonstrate or measure because to do so requires a broad understanding of the environment and how it works. In others the relationship is direct and easy to study.

A few pieces of equipment will enable you to arrive at some general hypotheses concerning the relationship of depth beneath the surface of liquids, and pressure on submerged objects. The relationship can be expressed easily in terms of measurement.

Materials and Equipment:

A glass funnel with diameter small enough to pass through the opening of a quart milk bottle.
Plastic or rubber tubing (to fit standard glass laboratory tubing snugly)
Rubber ballons
Glass tubing
Waterproof tape (the kind that can be used to repair garden hose)
Pegboard, masonite or scrap lumber to use for supports
Tall, leak-proof waste basket
Quart milk bottle
Bunsen burner or other heat source for bending glass tubing
Materials for making measuring scales
Rubbing alcohol
Table salt
Food coloring
Graph paper

Procedure:

This experience will require two or more laboratory periods. Work in groups of convenient size.

Although the accompanying diagram is provided as a general guide, the preparation and assembling of the equipment is your problem. There are alternative ways in which it might be done, possibly even better ways, if you wish to try another way, feel free to do so.

In any case, the glass tubing must be heated, bent to form a U-tube with one arm longer than the other, and mounted on a support. Ask your teacher to show you how to bend glass. The funnel may also be supported, but must remain movable. The thin, rubber membrane from the ballon must be fastened tightly across the opening of the funnel. The rubber of plastic tubing must be affixed to the glass tubing so that it is air tight.

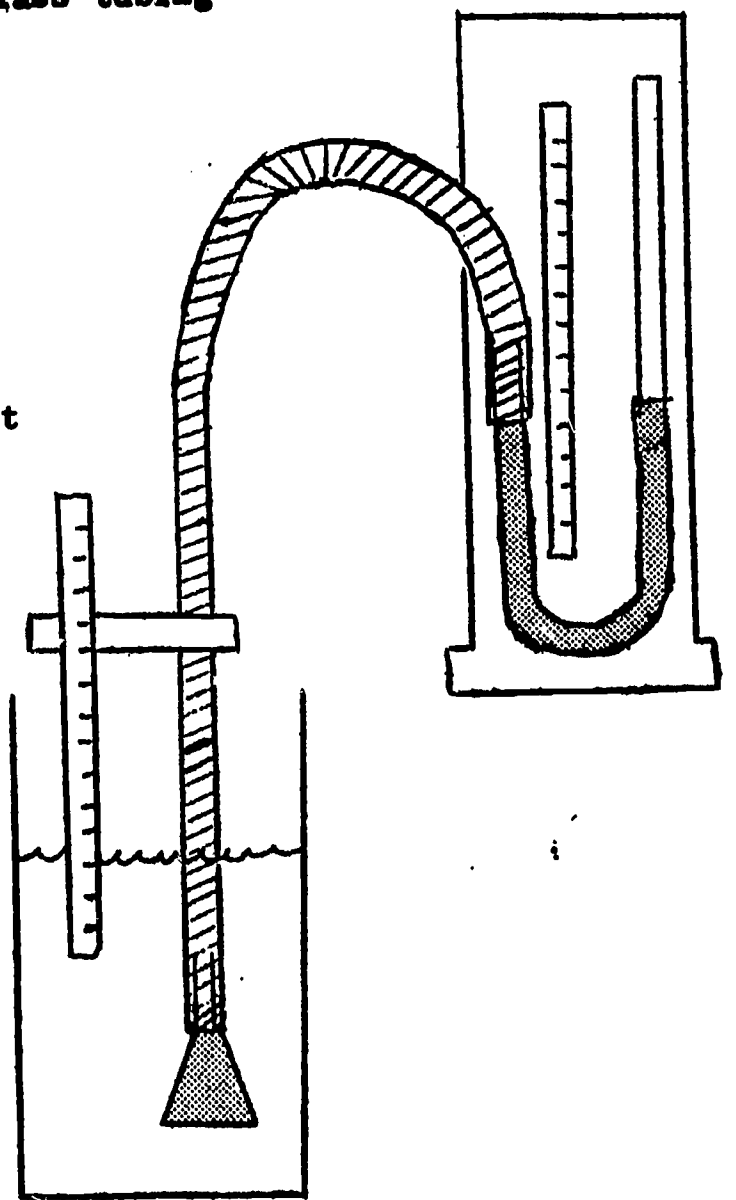

*In collaboration with Mr. William Kumbier, Bryant Junior High School, Livonia, Michigan, and Mr. David T. Smith, Coordinator of Science, Tucson Public Schools, Tucson, Arizona.

A means of measurement must be devised. Work out your own system of measurement. Devise a scale which does not use standard units, such as inches or centimeters, by the use of which you can calculate relationships between depth of the funnel opening beneath the surface and height of the column of colored water in the U-tube.

Pour water containing food coloring into the U-tube until it stands about 3 inches high in each arm.

Lower the funnel mouth in stages into the water in the wastebasket. As it goes deeper beneath the surface there should be a noticeable change in the position of the liquid in the U-tube. What happens? Is there a relationship between depth of the funnel mouth and level of the colored water in the U-tube? Why?

Repeat the experience and make careful measurements. Record these data for at least 10 depths. Is there evidence that there is an increase in pressure with increasing depth? Is this relationship constant? Graph your data:

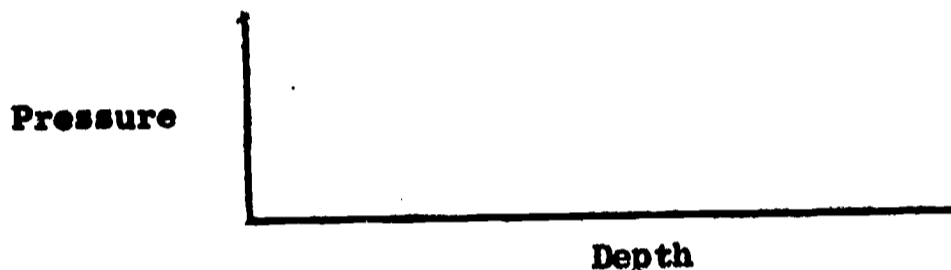

Repeat the experience, make the measurements, and construct another graph, using the milk bottle in place of the wastebasket.

When you have carried out this experience with both the wastebasket and the milk bottle, see if there is a relationship between the two sets of data. What conclusion can you draw?

Repeat the experience with the milk bottle, using a saturated solution of table salt instead of water. Compare your results with those obtained with water. What is the relationship? What conclusion can you draw?

Repeat the experience with the milk bottle, using rubbing alcohol instead of water. Compare your results with those obtained with water. With the salt solution. What are the relationships? What conclusion can you draw?

Further Consideration :

How are we justified in saying that measurements are only a quantitative statement of relationships?

What animals are equipped by nature for dealing with the environment beneath the surface of the water? What happens to a large whale when it runs adrift on a shore? What happens to a deep sea fish when it is brought to the surface? Why?

What happens when a skin diver goes beneath the surface of a pool, lake, river or the ocean? This is not a natural environment for a human. What equipment does he use for dealing with it? What are the hazards? Why do they exist?

What happens to a deep sea diver when he comes to the surface too quickly? Why? What about a submarine? With what devices is it equipped for dealing with the environment? How may the devices of a skindiver and a submarine be considered as tools for extending man's body and its capabilities? How are these devices which man has evolved to meet an environmental challenge comparable to the results evolved by nature in the case of water-dwelling animals to meet the same challenge?

Considering what you have learned in the experience, to what extent do you think it would be possible to build whole cities on the floor of the ocean? If this were done, would it constitute a further extension of man's body and its capabilities for meeting an environmental challenge?

*Volume, Weight, Pressure, and Physical State

Introduction:

Many aerosol devices are on the market: insecticides, dessert toppings, deodorizers, shaving creams and others. In all of them, a liquid and a gas are mixed and held under pressure. Upon release of pressure, the gas escapes, carrying the liquid with it in the form of mist or foam. Shaking may be necessary to achieve maximum mixture, prior to releasing the gas. In aerosol instant shaving cream, a liquid soap is mixed with a gas under pressure.

In this laboratory experience you will see that a quantity of material does not always remain the same size or volume. When the conditions under which it exists change, it undergoes resultant changes. You will see that some measurements are relative, being dependent on the physical condition of the materials being measured. Science is dynamic, and measurement is a concept for dealing with dynamic relationships as well as static ones.

"Margin of error" is related to the accuracy with which you are able to measure. In this experience you will see the importance of checking results and replicating procedures. The reliability of science depends on the repeatability of scientific experiences, within the range of a reasonable margin of error.

Materials and Equipment:

Can of instant shaving cream
Wide mouth canning jars of the same kind and size, with tops
Graduate cylinder
Laboratory balance
Means for removing top from can

Procedure:

Students should work in pairs or small groups.

A. First laboratory period

1. Weigh the can of unopened instant shaving cream.
2. Weigh the empty jars with their tops.
3. Spray the contents of the can into the jars, filling as many as necessary. As you fill a jar, you may need to stir the contents occasionally to eliminate large air spaces.
4. Mark each jar with tape at the level attained by the foam.
5. Weigh the jars containing the foam.

* In collaboration with Mr. Gerald Taylor, Farmington Senior High School, Farmington, Michigan.

6. Calculate the weight of the foam by subtracting the weight of the empty jars and tops.
7. Weigh the empty can, and calculate the weight of its contents by subtraction. Does the weight of the contents of the can correspond to the weight of the foam? Try to account for any differences that you find. Is the difference within a reasonable margin of error?
8. Screw the tops on the jars, and allow them to stand for one week.

B. Second laboratory period.

1. Note that a layer of liquid is now separated from the foam at the bottom of each jar. Examine the foam and see if it has changed, and is so, in what way. What do you think has caused the separation? What do you think was the physical state of the material in the can? What was the relation of the physical state of the original material to pressure?
2. Weigh the graduate cylinder which you will use in the next operation.
3. Pour the liquid from all of the jars into the graduate cylinder. You will find that you can pour the liquid out from under the foam along one side of the jar. If you do this slowly and carefully, the foam will not be disturbed, and very little of it will be carried off with the liquid.
4. What is the volume of the liquid?
5. Weigh the graduate cylinder containing the liquid.
6. Determine the weight of the liquid by subtraction. Is the weight the same as the weight of the contents of the original can? The same as the weight of the original foam in the jars? Are the differences within a reasonable margin of error?
7. Weigh the jars containing the remaining foam. Be sure to weigh the tops with them. Determine the weight of the remaining foam by subtraction. Compare this with the weight of the original foam. What do you think has happened? Why?
8. Add the weight of the remaining foam to the weight of the liquid. How does the total compare with the weight of the original foam? With the weight of the contents of the original can?
9. What conclusions can you draw from the data which you have obtained up to this point? What total volume of liquid do you estimate is represented by the liquid which is separated out from the foam, plus that which is still contained in it?
10. Wash all foam out of the jars, and fill them with water up to the level of the original foam. Measure this volume of water, using the graduate cylinder.

11. Remove the top from the empty shaving cream can. Wash it out. Fill it with water, and measure this volume of water, using the graduate cylinder.
12. How much greater than the volume of the can is the volume that was filled with shaving cream in the jars? How much of the volume of the can was occupied by the total volume of liquid estimated in step 9? How can you determine the approximate volume of gas that was also contained in the can? How accurate do you think your approximation is? Why? How much of the space in the can did this gas occupy? Assuming that your determinations up to this point have been reasonably accurate, how many times normal was the pressure under which the gas was held in the can?
13. Check the accuracy of your results, either by repeating the experience, or by comparing your results with those of one or more other pairs or teams, using the same methods and kinds of material. Was your margin of error, in relation to the replicated experience, within a reasonable range of expectation? Try to explain any differences that you find.

Further Considerations:

What is the relationship of the units used for measurement of volume and weight in the metric system? How are these related to measurement of length? What is specific gravity? How can you determine the approximate specific gravity of the liquid which separated out of the instant shaving cream? What is it? What does this indicate as to the solvent that was used to dissolve the soap?

What is the relationship of the three physical states of matter: solid, liquid and gas, to one another? Think of as many common examples of each state as you can. What examples of change from one state to another can you name?

What are the relationships between pressure, temperature, volume, and physical state? How can these relationships be expressed mathematically? What are the gas laws?

XI

Idea of Transference of Pattern

1. Idea-Bridge: "Patterning in Our World"
2. Laboratory Experiences:
 - a. "Replicating Simple Patterns"
 - b. "Transference of Pattern in Communication"
 - c. "Transference of Pattern in Heredity"

Idea Bridge: "Patterning in Our World"

Almost everything we do depends on some kind of pattern. We wish to build a house. We must first employ an architect to prepare a set of plans. These constitute patterns. In preparing the plans, the architect follows the general specifications set up by the city building authority for our particular plot or area. At each step, our activities with regard to building the house are guided by patterns.

A woman makes a dress. She follows a pattern. The decoration committee for a school dance cuts out stars and other figures from colored paper to hang from the ceiling. They make the use of patterns. The assembly lines in an automobile factory are set up for the production of a new model car. The patterns prepared by the engineers are followed in every detail.

The Federal government sets guidelines for the settlement of industrial disputes. The state educational authority adopts standards for the certification of teachers. The courts hand down decisions in specific cases which serve as precedents for dealing with future cases of the same type. We follow customs of long standing which are part of our culture. These determine our behavior, individually and collectively, with regard to courtship and marriage, death and burial, and other major events of life. All of the things cited in this paragraph are examples of patterns.

We carry on our daily activities largely on the basis of conditioned responses. We eat with certain table implements and utensils, used in a particular way. We dress each day in certain clothes which our society accepts as appropriate for our sex, age, and particular activities. Conditioned responses are patterns. Our daily problems are pre-solved for us in large part by these patterns. If it were not for them, each action on our part would have to be the result of a separate decision. Our days would be taken up with these trifling decisions, and we would have little time left for facing new problems involving decisions for which we have no patterns to follow.

In another unit (see Idea of Change and Variation), we find that natural laws are actually descriptions of consistently operating patterns in nature. Therefore, our use of patterns in the man-made world which we have built follows a precedent (or pattern) which was in existence long before we appeared on the earth. Since nature is as it is, and since man is a part of nature, it would have been impossible for us to operate in any other way.

We are concerned in this unit with the ways in which patterns, man-made and natural, are perpetuated or transferred. We will, of course, be able to examine only a few cases and methods of transfer. Some of these are quite simple. Others are very complex. First we will look at some of the simple ones, and then the more complex ones. You should follow the increasing complexity as far as you can. In doing so, you should always keep in mind that it is the idea of transference of pattern (to new examples of the same kind, to new media for carrying the pattern, to new generations of living things) that ties all of them together under a widely applicable principle.

Replicating Simple Patterns

Introduction:

We follow simple patterns in almost everything we do. When we use a pattern of any kind to make something like itself, we say that we replicate it. Theoretically, there is no limit to how many times we can replicate a pattern. When we use a pattern in this way, we say that it serves as a template. A key thus serves as a template in the making of a duplicate key. A dress pattern serves as a template for the cutting and assembling of the material for the dress. Using the same templates, it would be possible to make any number of keys or dresses, alike in all essentials. In this laboratory experience you will have an opportunity to examine various simple cases of replication, and to consider the idea of using various kinds of templates as a means of making easier the process of replication.

Equipment and Materials:

1. Automobile switch key, or other key of similar type
2. Other types of keys, if possible to obtain them
3. Availability of a place where keys are replicated
4. Sheets of 8½" x 11" typing paper
5. Scissors
6. Ruler

Procedure:

1. Have you ever watched a key being replicated? Take an automobile switch key, or other key of the same type, to a place where keys are replicated. Watch the duplicate key being made. How is it done? What is a "key blank"? Are all key blanks the same? How do they differ from one another? Ask the person who is replicating the key about the possibility of obtaining duplicates for other types of keys. What other types are there? NOTE: It would be well if you would collect as many different kinds of keys as you can, and take them with you, so that you can ask about them specifically.--How does a single key of the type that you have had replicated serve as a template for the making of duplicates of itself? Why cannot all types of keys be replicated in the same way?
2. Fold a sheet of 8½" x 11" typing paper in half three times. Make each of the folds as neat and even as you can. This will give you a rectangle of paper 8 ply in thickness, measuring 4½" x 2 ¾" on the sides. Now, cut out triangles or rectangles of various sizes from the edge of each of the four sides. Cut along straight lines. Now unfold the paper and see what kind of design you have made.

Using a ruler, replicate this design as accurately as you can. How will you go about it? Why? How many other ways are there by which it could be done? Is one method better than the others? Why? How long does your method take? Would some other method be faster? Which method would most nearly resemble the method used for replicating the key? Why?

3. Make a paper dart, as follows: Fold a piece of 8½" x 11" typing paper exactly in half, lengthwise. Fold one end of each half in, exactly to the center line. Fold the same end of each half in again, exactly to the center line. Now fold each half out, exactly to the center line.

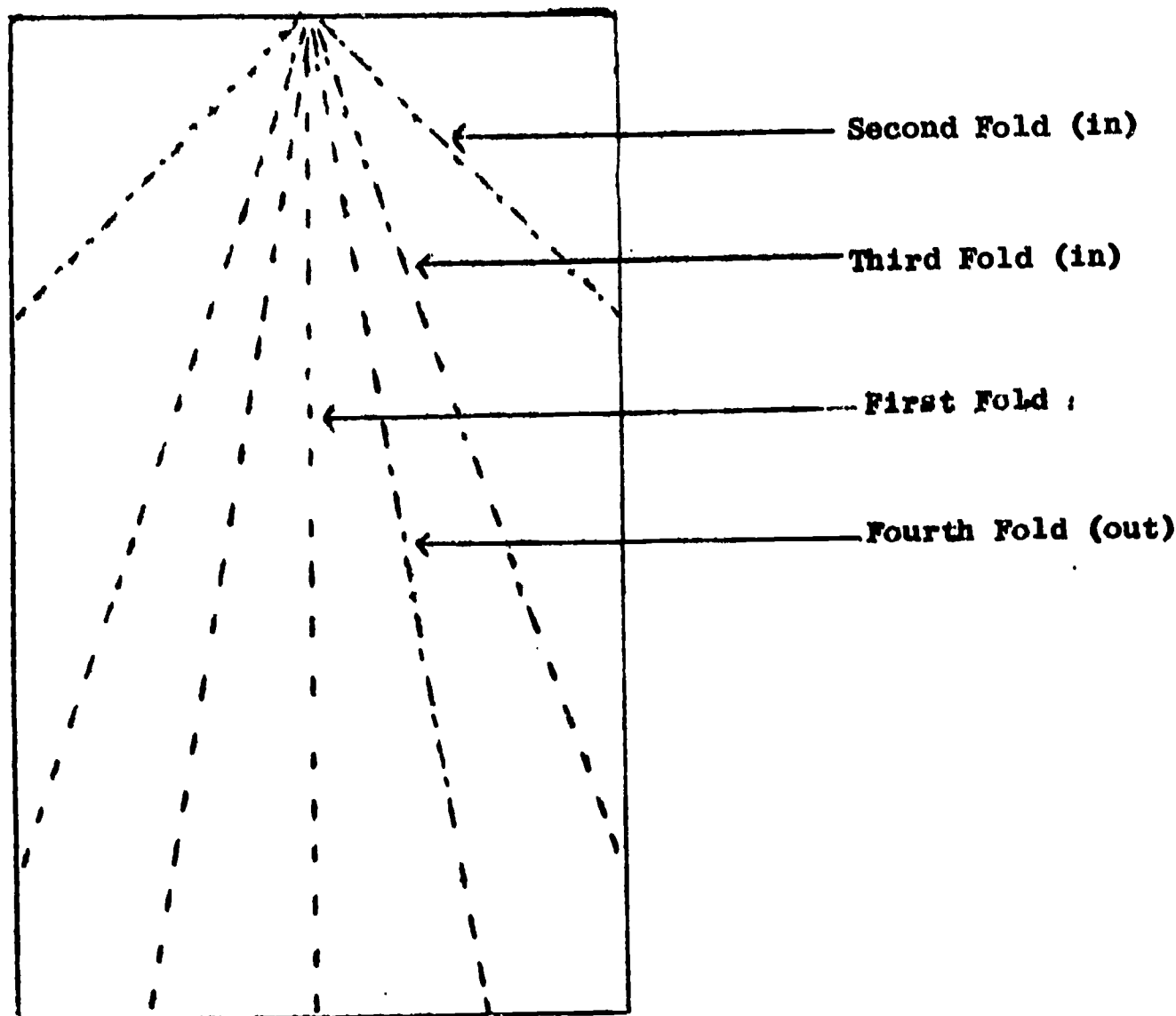

See how far you can sail the dart. Keep a record. You may work with another student and make a contest of it, if you wish. Try the dart at least ten times. What is the greatest distance attained? The average distance?

Do you think you could improve the dart by modifying the design? Try as many modifications as you think might serve as improvements. What design do you find most successful? Keep records of all trials. Replicate your most successful design, and test each copy of it several times to see if the results are consistent. Suggest an explanation for the success of your best design. Your tentative explanation constitutes an hypothesis. Can you think of a way to test your hypothesis?

How is what you have done to improve the dart related to the evolution of tools? How is it related to mutation and natural selection in the world of life?

Further Considerations:

Build a kite; make an article of clothing, or follow some other pattern of construction.

Examine each of the following for elements of patterning:

Conditioned responses in humans or other animals. What are they? What are some examples of them? How are they related to habits? In what sense are they patterns?

The idea of precedent in law and other human activities. What is meant by precedent? How is it related to patterning?

Laws, codes, guidelines, which govern human activities. Do they set patterns? How?

Architect's plans

The use of a map

How is the idea of replication of patterns related to mass production in modern industry?

Transference of Pattern in Communication

Intorduction:

People communicate mainly through hearing and sight. These senses in turn depend on patterns of sound and light. Sound and light are different forms of wave motion. All forms of waves, including waves on the water, which you can readily observe, have two basic characteristics. These are (1) wave length which is the distance from one wave to the next, and determines frequency; and (2) "wave strength" of amplitude, which in the case of waves on water, takes the form of the height of the waves. Waves of all kinds, including waves on water, are reflected from certain kinds of surfaces, they are also refracted, or turned from a straight line when they pass from a medium of one density into a medium of a different density.

An echo is due to reflected sound waves. An image observed in a mirror is due to reflected light waves. Watch water waves lapping against a dock after you have thrown a stone into the water. Can you observe reflection of these waves? Place a long pencil in a glass full of water. Does it always appear straight when you look at it from different directions? When it does not appear straight, this is due to refraction of light waves from the surface of the pencil when passing from the water into the air. What is an example of refraction in the case of sound waves? What is a mirage? What causes it?

The things that we hear: voices or other natural sounds, or music or other mechanical sounds, are made of a pattern of sound waves. These generally vary in both frequency and amplitude. Frequency determines pitch, while amplitude determines loudness or softness.

The things that we see are made of amplitude patterns (light and dark, or shades of gray) or of frequency patterns (colors). Amplitude, in the case of light waves, determines brightness or dimness. The colors that we see consist of light waves of different frequencies. These colors make up the visible spectrum. All of the colors of light in the spectrum, when mixed together, constitute ordinary light.

The different colors of light are separated from one another in the rainbow, or when light is passed through a prism (a block of clear glass). Sometimes a spectrum may be observed when sun light passes through an aquarium filled with water. In forming a spectrum the light waves of longer wave length (lower frequency) become separated from those of shorter wave length (higher frequency). This takes place because they have different degrees of refraction when they pass from the air into the glass of water, and out of it again. How is a rainbow formed through refraction? What are the colors of the spectrum that make up visible light? Which colors consist of light waves of higher frequency? Of lower frequency? In the case of light of a particular color, how would amplitude be expressed?

Are there related forms of waves that are of higher frequency than the shortest waves of visible light? Are they used for anything? Are there any living organisms that can see them? Are there related forms of waves of lower frequency than the longest waves of visible light? Are they used for anything?

Are light waves related to sound waves? How do light waves differ from sound waves? How do both kinds of waves differ from water waves? What other kinds of waves are there? How are these related to light waves, sound waves and water waves?

Equipment and Materials:

Radio, record player or television set
 Sheet of typing paper (8½" x 11"), not folded or distorted
 Phonograph record
 A piece of motion picture film, with sound track

Procedure:

1. You can see light wave patterns, consisting either of shades of light and dark, or of color (unless you are color blind). You can hear sound wave patterns. Can you also feel sound wave patterns?

Use a sheet of 8" x 11" typing paper. Be sure that it is flat, and not distorted in any way. With one hand, hold it between your thumb and forefinger at a point in the middle of the top edge. Hold it suspended in front of a radio, record player or television set that is playing loudly. Now, with the other hand, place the tips of your fingers lightly against the middle of the sheet of paper on the side away from the sound source. Can you feel any vibrations? Can you detect any differences or patterning in the vibrations?

What is the larynx of a human being? Where is it located? What is its function? How does it work? Place your finger tips against the larynx of a person who is speaking. Can you feel any vibrations? Can you detect differences of patterning in the vibrations? Can deaf people learn to understand a person speaking in this way?

Is it possible to feel light wave patterns on the skin? Is there any evidence that some people may be able to do this?

2. What happens to sound wave patterns, such as those made by a human voice or a musical instrument, that makes it possible for them to be transmitted over long distances, as in a telephone conversation, or in a radio or television program? What happens to sound wave patterns when they are recorded on a plastic disc, a magnetic tape, or the sound track of a motion picture film? How do they get from one medium to the other? What form do they take on the new medium? Find out all you can about the processes involved in transmitting and reproducing sound wave patterns over long distances, and the processes involved in preserving them on records, tapes, and film.

Examine the surface of a phonograph record under the low power of a compound microscope. Be sure that a strong light is shining on the surface of the record when you examine it. Note the grooves. Are they all alike? Follow a single groove. Is it the same at all points? Can you find evidence of a pattern in any of the grooves? What form does it take? Do all of the variations in a particular groove lie in the same plane? How is a sound wave pattern approximately like the original one produced from the record?

Examine the sound track on a motion picture film. What form does it take? Can you see evidence of patterning in it? What is this evidence? How is the sound track made? What relationship does it have to the original sound wave pattern? How is the pattern in the sound track changed back to a sound wave pattern approximating that of the original? Find out all you can about these processes.

3. The motion picture, Sound Recording and Reproduction (Encyclopedia Brittanica), if it is available, shows many of the processes about which questions have been raised in this laboratory experience. Another picture which will be helpful is Sound Waves and Their Sources (also Encyclopedia Brittanica). These may be located through any comprehensive film catalog.
4. How is sound recorded on tape? What form does the sound wave pattern take in this case? How is the sound wave pattern carried on radio waves? How are radio waves related to light waves? What is the difference in the way the pattern is carried in AM and FM radio? How is a picture broken up and broadcast, and then received and reassembled in television? Find out as much as you can about these processes. A local radio and/or television broadcasting station may well serve as a resource.

Further Considerations:

In what way may photographs, motion pictures, and printed page, be considered as examples of overcoming barriers of space and time by transference of pattern? Can you think of other examples?

Transference of Pattern in Heredity

Introduction:

We are accustomed to the idea that "like produces like". When animals reproduce, the progeny are animals like the parents, resembling them in general, and also, to a considerable degree, in detail. Among humans it is often possible to pick out the children of a particular parent or pair of parents from among a group of individuals of similar age. Careful study will reveal a greater degree of resemblance than casual observation. What is said here concerning animals is also true of plants.

Biologists have discovered the mechanism of heredity, and have identified the basic material which carries the heritable characteristics from parent to offspring--from one generation to the next. The gene or unit of heredity, is a part of a very large, string-like molecule of a substance called deoxyribonucleic acid (DNA). Molecules of DNA are found in the cores of chromosomes. Chromosomes are generally rod-shaped and can be seen readily in the nuclei of cells when the cells are in process of division.

Biologists have devised methods of studying the structure and behavior of DNA molecules, and have been able to make models representing their structure. In this experience you will be asked to look at chromosomes under the microscope; to see motion pictures; and to read a series of references. In some of the references the structural model of DNA is shown and discussed.

Some of the references are written at a level that you can read quite readily. Some are more difficult. Start with the simpler reading, and read as far as you can. As you go along, write down any questions that you would like to have answered, and raise them at an appropriate time in class.

Materials and Equipment:

Compound microscopes

Prepared slides showing mitosis in the Ascaris worm.

The following motion pictures:

Mitosis (EBF)

The DNA Molecule of Heredity (EBF)

The following books:

The Cell (Life Science Library), by John Pfeiffer and the Editors of Life, published by Time, Incorporated, and distributed by the Silver Burdett Company

How Life Began, by Irving Adler, Signet Science Library
P2135 (paperback)

The Wellsprings of Life, by Isaac Asimov, A Mentor Book
MD322 (paperback)

The Genetic Code, by Isaac Asimov, Signet Science Library
P2250 (paperback)

Procedure:

1. Look at demonstrations of the cycle of mitosis in the Ascaris worm set up under a series of microscopes. Read about mitosis and look at pictures and diagrams representing it. What is mitosis? What is the function of it? What do chromosomes look like? At what stage during the cycle of mitosis are they most readily observable? Why?
2. See the motion picture, Mitosis. Does the motion picture help you to see mitosis as a cycle of events within the cell? As a pattern that repeats itself?
3. See the motion picture, The DNA Molecule of Heredity. What is the relationship of DNA to chromosomes? What are genes? How are they related to DNA?
4. Read The Cell (Life Science Library), especially Chapter 3, "The Architect and the Master Builder." Pay particular attention to the portions that tells about deoxyribonucleic acid (DNA). Also look at the pictures and read the captions under them. Why is the DNA molecule called "The basic blueprint of life?" What is the shape of the DNA molecule? What is its structure? What are the units of which it is made? How many kinds of units are there? How does the DNA molecule replicate itself? What are mutations? What causes them? How do we know that a mutation has occurred? To what extent can we induce mutations? To what extent can we now control mutations? Do you think that we will ever be able to control them?
5. Read How Life Began, by Irving Adler. Pay particular attention to the section, "Inside the Cell", beginning at the top of page 40. Continue with the sections, "How a Cell Divides," "Messages in the Cell," "Chemical Regulators," "The Simplest Cells," and "At the Border of Life" in the pages that follow. Read the section "Molecules that Copy Themselves," on pages 98-99.

You will find excellent background, very simply written, in Chapter III of this book, "Elements and Compounds", pages 45-61, Chapter IV, "Carbon and Its Family", pages 62-86, and the sections in Chapter V called "Proteins" and "Anagrams and Patterns", pages 95-98. Read as much of this background material as you find helpful.

How is DNA related to protein formation? How are proteins related to enzymes? What are enzymes? What do they do in the living organism? Why has life been called "a bundle of enzymes in action?"

Additional Reading:

Read The Wellsprings of Life, by Isaac Asimov, especially the following chapters:

- Chapter 11. "Building Blocks in Common"
- Chapter 12. "The Shape of the Unseen"
- Chapter 13. "The Surface Influence"
- Chapter 14. "The Living Molecule"
- Chapter 15. "Passing on the Information"

Read The Genetic Code, by Isaac Asimov. Begin with Chapter One, and continue to read as long as you feel that you are understanding what you read. The early portions of the book are very simple. The material becomes more complex as you go along. How far are you able to read?

What can you say of the idea of transference of pattern as it applies to heredity? What is the pattern? How is it transferred?

Idea of Interdependence and Interrelationships

1. Idea Bridge: "Thinking About Dynamic Interdependence and Interrelationships in the Natural World"

2. Laboratory Experiences:
 - a. "A Study of Interrelationships: The Balanced Aquarium and the Pond Infusion Culture"
 - b. "Demonstrating Interrelationships: A Field Trip in the Laboratory"
 - c. Interrelationships of Physical Environmental Factors: The Evaporating Power of the Air"
 - d. "Plant-Animal Communities Are Everywhere: Forest Edge"
 - e. "Interrelationships: Communities and Environmental Factors on Your School Ground"
 - f. "City Birds"
 - g. "Interrelated Processes in the Human Environment"
 - h. "Interrelationships Involving Simple Human Experiences"

Thinking About Dynamic Interdependence and

Interrelationships in the Natural World

One of the most significant of the ideas which science has contributed to modern thinking is that of interdependence and interrelationships. Nothing in the universe stands alone. This is true of living organisms, physical phenomena, events of all sorts, everything that is dynamic, or that occurs. Things must be thought of and studied in their settings. If they are taken out of their settings they are not the same anymore. Everything is part of a picture, which, in turn, is part of a larger picture, and this of a still larger one, and so on out to the ultimate bounds of the universe, if, indeed it has any bounds.

Living organisms in nature exist in communities, which, in turn, cannot exist outside of a particular habitat, which is dependent on the physical factors of the environment. If a living organism, such as a frog, or a snail, or a beetle, or a man, is taken out of its natural setting, or out of one setting into another, it behaves differently, and, in a very real sense it is not the same organism anymore. The old descriptions of its behavior no longer apply. Can you think of any examples of this kind of thing that are applicable to children? Or to grown-up people?

Various factors of the physical environment change in relation to one another: depth and pressure, temperature and pressure, rate of evaporation and wind movement, rate of erosion and slope. In some cases several simple physical factors interact to produce a single complex one such as the evaporating power of the air.

Any event is the resultant of many complex causes interacting with one another, even though one particular cause may seem at first to overshadow all others. Careful study will bring others to light. There is no single event that does not affect other events that come after it. If you had not moved to the place where you now live, you would not know the same people that you now know. You would be different and they would be too. The event of your move brought about or affected other events that would not have happened at all, or would have happened differently if you had not moved or had moved somewhere else. Try to think what might or might not have happened in some particular case.

There is nothing that is not influenced by other things. Try to think of something that stands alone. A stone? A day? A chair? A piece of metal? A star? Try to think of the influences which affect any one thing. Then think of the influences which affect these influences. Try to find a stopping place. Can you?

A Study of Interrelationships: The Balanced Aquarium and the Pond Infusion Culture

Introduction:

The ideal way to study plant-animal communities is to go on a field trip to see them. It is not always possible, however, to do this. Time, distance and facilities may not permit it. The following set of experiences may therefore be used as a substitute. They may also be used to supplement a field trip to a pond or lake.

A balanced aquarium is a miniature pond in the laboratory. The succession of forms of microscopic life in a pond infusion culture leads ultimately to a small balanced community which is comparable to a balanced aquarium. A study of a balanced aquarium and a pond infusion succession will help to develop an understanding of the interrelationships involved in the larger communities of living nature: ponds, lakes and forests, and the processes of succession through which these pass in developing a relatively stable (dynamically balanced) condition.

In setting up these experiences, you can proceed on your own, but you must be careful. Slipshod procedures, or failure to follow directions may result in failure of the aquarium to come to balance, or failure of the infusion culture to go through a normal succession. Exact results in any case are impossible to predict. The development of the culture, however, should follow a predictable general pattern. Failure of the culture to do so, or variations from the pattern, will furnish interesting opportunities to suggest hypotheses as to possible causes, and may constitute the basis for further experimentation.

Balanced aquaria may be set up on an individual basis. Infusion cultures lend themselves to group activity, but at least six different cultures should be set up by teams of students in the class in order to make possible a study of variations in their behavior.

Materials and Equipment:

- Gallon and quart size glass jars
- Compound microscopes
- Medicine droppers
- Slides and cover slips
- References for identification of aquatic organisms

Procedure:

Constructing a Balanced Aquarium

Obtain a jar or other clean glass container of at least one-gallon capacity, which has an opening large enough that you can get your hand into it.

Get some river or lake shore sand as free of dirt and debris as possible. Wash it thoroughly through several changes of water. Place sand in the bottom of the container to a depth of two inches. Fill the container with water to a level such that when you put your hand to the bottom the water will not overflow. Allow the sand to settle until the water becomes reasonably clear.

Put a number of aquatic plants into the aquarium. Collect them from a pond or a quiet pool in a stream or purchase them at an aquarium or pet store. You may use more than one kind of plant, some floating (duckweed), some rooted in the sand with the main plant body submerged in water (eel grass or elodea), and some rooted but having floating leaves. Why would it be unwise to get plants from an actively flowing stream? What advantage might there be in obtaining your plants from an aquarium store? Why? Watch size relations. Do not put large plants into a small container.

Put a few aquatic animals into the aquarium. Why "a few"? Snails are the best animals for this size container. Larger animals would be difficult to support in so small an aquarium. Why? Most snails are herbivores (plant eaters) and are more likely to find an adequate food supply here. Do not include tadpoles, because these, as adult frogs, live outside of water. Do not include aquatic insects or fish. Many of them are carnivores (animal eaters) and probably would not have enough food and oxygen for very long. To support carnivores, a balanced aquarium would have to be much larger and contain many more plants and small herbivores. How much larger do you think it would have to be? Why? If you have been successful in building your aquarium, it will become balanced at the "snail level".

Cover the jar with its own lid or glass cover, or with Saran wrap, to minimize water loss through evaporation. Allow your aquarium to stand for at least two weeks. If, at the end of two weeks, the water is clear, if it smells "fresh," and if the plants appear healthy and the animals are alive, the aquarium is approximating a balance. The longer it continues in this condition, the more probable is the balance.

Your balanced aquarium will maintain itself successfully in any window during the winter months. An east or north window is best for a year-round location because the aquarium is more stable in a place where it receives plenty of strong indirect light, and only a small amount of direct sunlight. In summer, west and south windows are too hot for an aquarium.

Although daily and seasonal light and temperature changes in the classroom are not as extreme as they are out-of-doors, such changes do occur. You can watch the changes that take place in your aquarium as the seasons change.

List the different kinds of plants and animals that have become established in your aquarium. What is the relationship of each life form to the aquatic community of which it is a part? What are the sources of oxygen, carbon dioxide and mineral salts for food-making

and respiration? What about the activity of colorless plants? What evidence do you see for their activity?

The final result of your balanced aquarium experience is an aquatic micro-community which should remain relatively unchanged over a long period of time, if the conditions of its environment are not changed. The only way available for us to judge the achievement of this balance is by observing its continued success. Chemical analysis might be possible, but not at the level at which we are operating. Nevertheless, the judgment of a biological result on the basis of a kind of biological test or assay is a method widely used. What other examples of it can you think of?

Setting Up A Pond Infusion Culture

Fill a quart jar about 3/4 full with plant material from the edge of a pond, including some of the floating and submerged green vegetation and some of the dead vegetation from the pond bottom. Be careful not to include mud. Fill the jar to a point near the top with water taken from the area where it has been stirred up. In doing this you will have secured a representative sample of the microscopic aquatic organisms in this environment.

A sample secured in this way will contain a maximum variety of microscopic forms. Not all of them will appear, however, on immediate microscopic examination. Therefore, the jar should be allowed to stand for twenty-four hours. By this time the organisms will have oriented themselves to the changed situation, and a more accurate survey can be made.

A pond infusion culture consists simply of a jar of material obtained in this way, and allowed to undergo the natural changes which occur over a period of days or weeks as a result of the changed environmental conditions to which it is exposed in the laboratory.

When kept in the laboratory, the culture should be placed in a window, but not allowed to stand in direct sunlight. It should be moved as little as possible. The same side of the jar should be kept exposed to the light from the window. Why should the culture be maintained in this way? In what ways does the laboratory environment differ from the pond environment? What physical factors of the environment are changed when the material is brought into the laboratory, and to what extent? What biological factors are changed, and to what extent? Predict possible effects that these changes may have on the living organisms brought in from the pond, and then try to determine the validity of your predictions during the period of your observation of the developing culture.

Succession in the Culture Jar Community

In securing samples from the culture jar for study under the microscope, fill a medicine dropper as you scrape the end of it up and down through the top film of the water against the glass on the

side of the jar nearest the window. By this means you should secure a sample of the organisms in approximately the top one-fourth inch of the water. What environmental factors are you taking into consideration when you take a sample in this way? How do these operate in the plant-animal community?

In addition to any other considerations involved in taking samples in this way, there is the advantage afforded by uniformity. Samples which are taken in the same way each time the culture is studied make possible a comparison of results. Additional samples may be taken from other parts of the culture, using different methods of sampling, but these also should be uniformly obtained. Such samples may be compared with the ones taken as indicated above. In every case at least three samples should be studied from any locality in any particular jar on each occasion. Why?

In identifying the organisms observed, the following standard and easily obtainable reference books are helpful:

1. Eddy, Samuel, and Hodson, A. C., Taxonomic Keys to the Common Animals of the North Central States. Burgess Publishing Company, Minneapolis, Minnesota, 1955.
2. Needham, James G. and Needham, Paul R., A Guide to the Study of Freshwater Biology. Holden-Day, Inc., San Francisco, California, 1962.
3. Jahn, T. L., How to Know the Protozoa. William C. Brown and Company, Dubuque, Iowa, 1949.
4. Ward, H. B., and Whipple, G. C., Freshwater Biology. John Wiley and Sons, New York, 1918. (Second Edition, W. T. Edmondson, editor, 1959.)

Since common plankton forms are generally world-wide in their distribution, any good reference book on microscopic aquatic organisms will be useful. Any reference book used, however, should contain pictures or sketches of the common organisms for ready identification. Keys are necessary for detailed identification, but for the type of recognition involved here, time is not available for such identification, nor is it necessary. It is better to leave an occasional animal unidentified than to "lose sight of the forest in studying the trees". The goal of this experience is to understand the interrelationships which exist in the community, not to identify a large number of organisms.

Ask your teacher to verify the identification of the organisms that you have seen. Your teacher may then draw rough sketches of these organisms on the blackboard, emphasizing such readily observable characteristics as body shape, size, and outstanding features of appearance. Sketches of this type will enable others to recognize the organisms if they see them. It is well if these sketches can remain on the board during the progress of the study, being supplemented with additional ones as new organisms are discovered. Usually all of

the more common organisms in the culture are identified during the first few periods of observation. Remember that all organisms which appear at any time during the development of the culture must necessarily be derived from those which were present at the beginning. Nothing new is introduced.

If you wish to do so, you may avoid all identification of genera and species of the microscopic animals and plants by simply placing the organisms that you observe in a few major groups: (1) flagellate protozoa, (2) ciliate protozoa, (3) rhizopod protozoa, (4) microcrustacea, (5) miscellaneous arthropods, (6) worms, (7) single-celled and colonial green algae, (8) filamentous green algae (9) diatoms (10) blue-green algae, and (11) bacteria. This procedure has certain advantages from the standpoint of summarizing results, and it is very easy to carry out.

The culture may well be examined daily during the first week or even two weeks. If it is desirable to carry on other class activities during this time, however, examination on alternate days will be sufficient. The changes during the first two weeks are rapid and interesting. After the first two weeks, examinations once a week or even less often will be enough to detect the slow changes which are occurring. After six weeks, a single examination at the close of the semester or the school year will serve for comparison with the balanced aquarium. If old culture jars are available, containing mature cultures from previous years, these also may be studied and used for purposes of comparison.

Work out a means of quantifying your data. This may be done by combining the results of the entire class at the close of each period. Use the sketches on the board in helping to determine class totals. Exact counts are not necessary. It is usually sufficient to state results in terms of rough categories such as, "very abundant", "abundant", "many", "few", and "rare". Quantification of this kind serves as a useful summary of the work of each period, and helps to present to the class a picture of the changing scene of the culture as the succession progresses.

In general, the predominant organisms in the culture during the first few days are those which are common in plankton samples taken directly from the pond: microcrustacea, green algae, diatoms, blue-green algae, aquatic annelids, insect larvae, other micrometazoa, and protozoa in small numbers. After a few days, the green forms, the microscopic metazoa and some of the kinds of protozoa become fewer in number and disappear. Processes of decay set in, bacteria multiply and are seen in large masses, and the ciliate protozoa (paramecium and others) that feed on bacteria become abundant. This stage may last for several weeks. Then, as decay runs its course, the bacteria and bacteria-feeders diminish; the green and blue-green algae become abundant again; such microscopic metazoa as have lived through the period of decay are again seen in small numbers; and the culture slowly attains a balance. Ultimately it becomes a miniature balanced aquarium, balanced at the microscopic level.

At this point, a comparison with the gallon jar balanced aquarium which was constructed at the beginning of the study should be made. How are they similar? How do they differ? Why? Why was it possible to construct the larger balanced aquarium without its having to pass through the succession stages which took place in the case of the culture jar? How are both of the balanced aquaria similar to the plant-animal community of a pond, lake or the ocean? How are they different?

Further Investigations:

What are the implications of the pond infusion culture-balanced aquarium study for understanding some of the methods of purification of city water supplies? For some of the methods of treatment of sewage? Visit a city water plant and a city sewage disposal plant if possible, and see these processes in operation.

What are the implications of the study for a possible part-solution of the problem of a food supply for the world's future dense population in the form of "farming" the rivers, lakes and oceans for food? What are the implications for maintaining a food supply in a space ship traveling vast distances over long periods of time? What kinds of research are now being done on both of these problems?

What kinds of controlled or semi-controlled experiments could be set up to study further the problems raised by the pond infusion culture? Set some of these up and try them.

*Demonstrating Interrelationships: A "Field Trip" in the Laboratory

Introduction:

Plants and animals are dependent on one another and on their physical environment. The interrelated organisms living in a particular habitat constitute a plant-animal (biotic) community. A simple classroom activity will help to demonstrate the complexity of the relationships that exist in plant-animal communities, the interdependence of living organisms, and their common dependence on physical environmental factors.

The class should be divided into committees of convenient size, each of which will construct a set-up for a specific plant-animal community. Only communities which are well known to the committee members should be used. Some of these might be (1) a forest edge, (2) a forest floor, (3) a pond, (4) a pond edge. Equally good possibilities are: a suburban back yard, an area in a nearby park, an area on the school ground. If the committee is not thoroughly familiar with the community, it should be studied by the committee members in preparation of the laboratory experience.

Materials:

A ball of string
5" x 8" cards
Masking tape
Thumb tacks

Procedure:

List as many plants and animals as you can from the community that you are studying. Discuss the interrelationships which exist among the organisms in the community, and the physical environmental factors on which they depend.

Prepare a 5" x 8" card for each organism listed. The card should bear the name of the organism, and the physical environmental factors which affect it directly (e.g., golden rod; sunshine, rainfall, etc.; land snail; moisture, shade, etc.--scientific names are not necessary.)

Arrange the cards in a convenient fashion on the top of a table, and fasten them with masking tape; or arrange them on a pegboard, fastening them with thumb tacks.

Run a string from each card, representing an organism, to each card representing another organism to which it is in any way related. The relationships may involve food, predation, cover, nesting sites, and any others that the committee members can think of. Fasten the strings to their respective cards with either single tabs of tape or thumb tacks.

Prepare a list for each organism, including the names of the other organisms to which it is related, and the nature of the relationship in each case.

In collaboration with Dr. Beth Schultz, Department of Biology, Western Michigan University. Idea derived from material by Dr. Verne N. Rockcastle, Department of Science Education, Cornell University.

Now vary or eliminate any single physical environmental factor (e.g., light rainfall, temperature), and determine by inspection of the cards (1) what organisms would be affected directly, (2) what organisms would be affected indirectly, by the direct effect on organisms to which they are related, and (3) what the effect would be on each organism affected either directly or indirectly. Keep a record. Do this for several environmental factors.

Of what does weather consist? Climate? What is the relationship between weather and climate? Why does climate tend to remain constant from year to year for long periods. What would be the effect on plant-animal communities if climate were less constant? Have there ever been times when climate changed? When? What happened? Are there any evidences of short-term climatic change? What are they? What happens when they occur?

Now vary (increase or decrease in numbers) or eliminate any single organism in the web of relationships. Determine by inspection of the cards and the strings representing relationships between them (1) what other organisms would be affected (a) directly, or (b) indirectly, and (2) how they would be affected. Keep a record of the nature and extent of the effects. Do this for several organisms in your web of relationships.

Are some organisms more important to the Community than others? What is meant by "key organisms"? What makes them so?

What is meant by the "balance of nature"? Is there really such a balance? On what does it depend? What is meant by "dynamic balance"? Try to define a plant-animal community, including both living organisms and physical factors in your definition. What is meant by an ecosystem?

Further Considerations:

What is meant by conservation? Is the same thing always meant when people talk about conservation? How is conservation related to plant-animal community structure and function? What is meant by "constructive" and "destructive" activities of man? In terms of purely human standards? In terms of nature? Do the preceding questions specifying "purely human standards" and "in terms of nature" imply a contrast? If so, what is it? Try to frame your own definitions of "constructive" and "destructive" activities. List as many of both kinds of human activity as you can. Try to frame your own definition of conservation.

Interrelationships of Physical Environmental Factors: Evaporating Power of the Air

Introduction:

Climate has been called "year-to-year weather", and weather "day-to-day climate". When we think of the physical environmental factors that make up weather, however, we tend to think of them separately: temperature, relative humidity, wind movement, barometric pressure, light. Actually they are all interrelated in their action and their effect on living organisms. Indeed, it is sometimes difficult to separate their effects.

Apparently the factor which has the greatest influence on man is a composite one: changeability and storminess. This involves most of the basic weather factors. It is expressed in the day-to-day weather changes which appear to be related to the high rate of physical and psychological activity characteristic of the more favorable climatic regions of the world.

One component of this general climatic factor is the evaporating power of the air. This is itself a composite of several physical environmental factors: temperature, relative humidity, wind movement, barometric pressure, and possibly others. A laboratory experience can be set up with relative ease which will enable you to explore the interrelationships of some of these factors and arrive at your own conclusions concerning their operation.

Equipment and Materials:

Thermometers

Pan for boiling water

Electric fan (two speeds)

Rubber bands

Wide mouth jar

Saran wrap

Ring stands or other device for holding thermometers erect

Small piece of woolen cloth

8-ounce drinking glass or tumbler

9-inch pie pan

Potted cactus or other plant without leaves

Potted geranium or other leafy plant approximately the same size
as the cactus

Razor blade

Glass microscope slides

Microscope or hand lens

Plastic bags

Sponge

Procedure:

1. Using two identical thermometers (Centigrade or Fahrenheit), test a variety of temperatures. Be sure to leave the thermometers in each location long enough to insure an accurate reading. How long is "long enough"? Why?
 - a. room
 - b. in the sun
 - c. near a radiator or other source of heat
 - d. immediately above a pan of boiling water
 - e. in front of an electric fan:
 - (1) at low speed
 - (2) at high speed

Do the two thermometers register identical temperatures in all cases? If not, are the differences consistent? If there is a consistent difference, record it, and use it as a correction factor in all future readings.

2. Wet a small piece of woolen or other heavy cloth (with distilled water if it is available), and fasten it with a rubber band around the bulb of one thermometer. Support the thermometers in an upright position, side by side, about three inches apart. Be sure to keep the cloth wet while you are carrying on the experience.
3. Record the dry bulb and the wet bulb temperatures in the same locations that you tested before. Be sure to leave them in each location long enough to insure an accurate reading. How long is "long enough" in this case? Why is there a difference between the dry bulb and the wet bulb temperatures? Where do you find the greatest difference between the dry bulb and the wet bulb temperatures? Why? Where the least? Why?
4. Record the dry bulb and the wet bulb temperatures in front of the electric fan, at both high and low speeds
 in the sun
 near the radiator (or other source of heat)
 over a pan of boiling water
 Compare these readings with the ones obtained in the same locations without the fan. What differences do you observe and what conclusions can you draw? Why?
5. Starting with a freshly wet cloth on the wet bulb thermometer, let the thermometers stand at room temperature until the cloth is dry. Record the temperatures on both thermometers on a single sheet of graph paper every five minutes. What is the relationship between them? Do the same thing in front of the fan (a) at low speed, and (b) at high speed. Record the results in the same way in each case. What is the relationship of the three sets of data? Why?
6. Put two or three inches of water in the bottom of a wide mouth jar. Cover the jar with Saran wrap. Insert two thermometers, one dry bulb and one wet bulb, side by side, through two small holes (as small as possible) in the Saran wrap. Devise a means of holding them erect above the water.

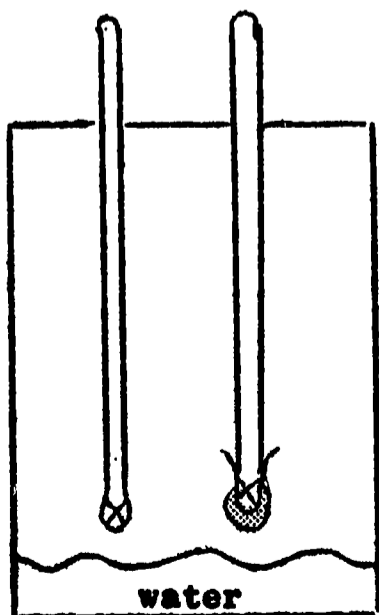

Allow this set-up to stand in a warm place (in the sun or near a radiator) for several hours. What is the relationship between the dry bulb and the wet bulb temperatures? Why? Which of the locations used earlier is most nearly comparable to this situation? Why?

7. Fill an 8-ounce drinking glass with water. Pour it into a 9-inch pie pan. Refill the drinking glass with water. Allow both containers to stand at room temperature for 24 hours or longer. Measure the amount of water remaining in each. What is the relationship? Why? Calculate the surface area of the water in the pan and in the glass at the start of the experience. How many times larger is the exposed surface of the water in the pan than in the glass? Is this relationship proportional to the difference in the evaporation rate in the two vessels? Can you think of any factors that might enter into the situation to modify this relationship?
8. Fasten plastic bags as closely as possible around:
 - a potted cactus or other leafless plant
 - a potted geranium or other leafy plant approximately the same size

The pots should be the same size, and both plants should receive the same amount of water at the time the bags are fastened around them. The bags should be fastened around the bases of the plants rather than round the pots, and should allow approximately the same amount of space inside the bag around each plant. Place the plants side by side in the sunlight, and allow them to stand for a few hours. Remove them to a cool place, and allow them to stand until moisture droplets form on the inside of the bags. Compare the amounts of moisture collected on the inner surface of the plastic bags. Where did it come from? What are the relationships? Can you suggest reasons for any differences that you observe? Why did the moisture not appear when the pots were in the sunlight?

9. With a razor blade remove a small portion of the surface layer of the cactus, and of the leaf of the other plant. See if you can tear off a thin strip of the surface layer. This may require several attempts, and a little practice. Put a specimen from each plant in a drop of water on a microscope slide. Examine it with the lowest power of the microscope, or with a hand lens if a microscope is not available. Describe any differences in structure that you are able to observe. What is the relationship of the surface structure of the plant to the evaporation of water from the plant? How does the amount of water evaporated from an acre of green vegetation compare with that from an acre of bare soil? From an acre of open water?

Further Considerations:

Summarize what you have found out about the interrelationships of physical environmental factors involved in the evaporating power of the air. What factors do you think are involved other than the ones you have studied? What effect do you think these have, and how do they enter into the picture? What do meteorologists mean by the "comfort factor"? What does it include?

How is relative humidity measured? How is it related to the actual amount of water vapor in the air (absolute humidity)? Immerse a sponge beneath the surface of water and allow it to become completely filled with water. Remove it from the water and squeeze approximately half of the water out of it. Release the pressure on it and allow it to resume its natural shape. Explain how this constitutes a model which illustrates the condition expressed by "50 per cent relative humidity". Why does relative humidity increase with falling temperature? What is dewpoint?

How are rainfall and other forms of precipitation related to relative humidity? What additional factors enter into the occurrence of rainfall and other forms of precipitation? Listen to or watch weather forecasts on radio or television. Find out how they are made and the kinds of information on which they are based.

Plant-Animal Communities Are Everywhere: Forest Edge

Introduction:

Plants and animals in nature never live alone. They are always associated with other plants and animals, usually with some belonging to species different from themselves. Organisms that live together influence one another. Together they make up the living environment of one another. The living environment is influenced by, and in turn, has an influence on the physical environment (temperature, relative humidity, wind movement, light, soil.) The plants and animals that live together in a particular habitat, interacting with the environment (living and physical) constitute a biotic (plant-animal) community.

There are many different kinds of biotic communities. Some exist in water and are called aquatic: ponds, temporary pools, small streams, rivers, lakes, and communities in the ocean. Others exist on land and are called terrestrial. In any region which was formerly covered with forest, one of the commonest kinds of terrestrial communities is forest edge. This community has certain characteristics by which it may easily be recognized. These characteristics indicate environmental conditions which determine the kinds of plants and animals that live in the community.

Forest edge conditions always include:

- (1) partial or open shade, as contrasted to the closed shade of a forest and the open sunshine of a grassland.
- (2) a mixture of vegetation types: trees, shrubs, broad-leaved plants that grow up each year and die down with frost, grasses, and sometimes vines.
- (3) a tangle of vegetation, through which you would want to seek for a path if one were not readily available.

Such conditions may be found not only at the edge of a woods, but also in many other places. Therefore there are communities of forest edge type which are found in field borders, along roadsides, in brushy pastures and abandoned areas, and in towns and cities, wherever people have planted trees and shrubs or have allowed them to grow. Such communities, which show forest edge characteristics but are not attached to a forest, are called "detached forest edge". Most of them have been created by man, or allowed to develop in connection with his uses of land.

Procedure:

Visit the edge of a woods, if one is available, and observe the general conditions of the forest edge community. Note the three characteristics listed above. To what extent are they present? Do not take time at this point to identify the plants, although if you know some of them it is helpful. Do you observe any animals? Remember that insects, snails, worms and other invertebrates are animals, as well as mammals and birds. Look for invertebrates in the litter of living and dead vegetation on the surface of the ground, and in the surface layer of the soil.

If a woods is not available, look for the same kind of conditions in the wooded and brushy portion of a park or other available area.

When you are sure that you have a mental picture of forest edge conditions, look for detached forest edge communities. If you are in the country, look at roadsides, field borders, brushy pastures, abandoned fields. Is there any correlation between rough terrain (hills, gullies, streams) and the occurrence of forest edge conditions? Small areas of woodland which continue to exist in an agricultural countryside are called "relict woodlands". Is there any correlation between the occurrence of these and rough terrain? Is there a relation between these and detached forest edge conditions?

If you are in a town or city, look for detached forest edge situations wherever you can find them. Their occurrence in parks has already been mentioned. What about the occurrence of forest edge conditions around dwellings where trees and shrubs have been planted? What about school grounds? What about landscaped areas around public buildings? Around industrial sites? What about cemeteries? Describe some of these in terms of detached forest edge.

Examine urban waste areas for evidences of forest edge: railroad rights-of-way, the edges of parking areas, vacant lots, the foundations of wrecked buildings, city dumps. What elements of forest edge, plant and animal, do you find in these places.

Go into the center of a town or city, where at first glance there is nothing in the way of visible life other than humans. Can you find any other living things? Are there any birds? What are they? Are there any insects? Look in cracks in the sidewalks and at the foundations of buildings. Do you find any other animals? What other animals do you think you might find if you were able to look in the right places? Where would you look? What plants do you find? Where?

Select an urban waste area within walking distance of your school, or work on a portion of the school ground. Examine a typical area, as large as possible, but with definite boundary lines and of calculable size. Try to discover all of the kinds of plants and animals that are in it. Count or calculate the number of each kind. With the smaller species you may find it necessary to count the number in a small, typical area (for example, one square yard) and calculate from this the approximate number present in the total area. What are the most abundant species of plants? Of animals? How is this related to size? Are the smaller species always the most abundant? Try to account for the relative abundance of some species and the relative scarcity of others. Try to determine the relationship of each species to its environment, and to the community as a whole. Remember that the micro-environment, that is, the environment immediately surrounding a small species of plant or animal, is more important for it than the macro-environment of the entire community.

Scientific names (genus and species), while desirable and useful if they are readily determinable, are not necessarily required for this experience. The goal of this experience is to study relationships rather than to identify animals and plants. Identification is a means to an end rather than an end in itself. Common names, such as "spring beauty" or "thirteen-lined ground squirrel", or even assigned names, such as "snail #1", "snail #2", and "snail #3", or "small lavender-flowered mint", will suffice if more detailed identification is not readily possible.

You may find the following method of tabulation helpful:

Trees:

<u>Name of Species</u>	<u>Number per Unit of Area</u>
1. ----	-----
2. ----	-----
3. ----	-----

Shrubs:

<u>Name of Species</u>	<u>Number per Unit of Area</u>
1. ----	-----
2. ----	-----
3. ----	-----

Continue for Broad-leaved Plants, Grasses, Vines, and Other Plants.

In the same way for animals, list Birds, Mammals, Other Vertebrates, Insects, and Other Invertebrates.

You will find the following books helpful: Rickett, Harold W., American Wild Flowers, G. P. Putnam's Sons, New York.

Petrides, George A., Field Guide to Trees and Shrubs, Houghton Mifflin Company, Boston.

Peterson, Roger Tory, A Field Guide to the Birds, Houghton Mifflin Company, Boston.

Lutz, Frank E., Field Book of Insects, G. P. Putnam's Sons, New York.

If you do not have these books available, any other field books with illustrations and descriptions will be useful. The books listed above will be particularly helpful in Michigan and elsewhere in the eastern United States. In the western United States it may be necessary to supplement them with other regional field guides.

To what extent does your study area fulfill the general conditions of forest edge? What is the relationship of man to the area? What evidences of human influence and activity do you find? What do you think would happen to the area if human influence were removed? Do you think that there are any animals that may live in or frequent the area that your study has not shown? How do you think you might learn about these?

Many of the plants and animals that are found in urban waste areas are not native to North America. They were introduced, mainly from Europe. Some of the plants are garden escapes; others are commonly called "weeds".

There is no good term for the animals in this group, but sometimes they are called "campfollowers". See if you can find out which of the plants and animals that you have found are introduced species. Why do you think they are found in this habitat?

Further Investigations:

Study other detached forest edge situations in the same detailed fashion in which you have studied an urban waste area. Identify as many of the plants and animals as you can, and determine their relative numbers. Try to learn their relationships with one another so that you can see what makes the forest edge a biotic community.

Study one or more of these habitats through an entire season, or through a whole year. What changes take place in it from the standpoint of its general aspect? From the standpoint of the plants in it? From the standpoint of the kinds, numbers and activities of the animals in it?

Study a forest edge community at the edge of a woods in the same way. What differences do you find between (a) the urban waste area, (b) other kinds of detached forest edge communities, and (c) forest edge at the edge of a forest? What are the kinds and relative importance of human influence in each? Can man be considered a member of the biotic community?

***Interrelationships: Communities and Environmental Factors**
on Your School Ground

Introduction:

No matter how small or barren your school ground may be, you may find a wide variety of physical conditions in various locations within it. Of course, if your school ground is large, with varied kinds of landscaping and plantings, there will be an even greater variety. These physical conditions help to determine what plants and animals are found, and the extent to which they are able to be active, grow, and multiply. It is not necessary to use elaborate equipment in order to describe meaningfully the variety of conditions that exist on your school property. Careful observation with tools that you have at hand or can readily devise will enable you to collect significant data and make valid comparisons.

Equipment and Materials:

Yard stick
Wooden stakes
Thermometers
Light meter
Hand water sprinkler
Cylinders made from tin cans with both ends removed
Watch with second hand
Pointed pencil or wooden dowel
Small piece of woolen cloth or piece of hollow shoelace, with
the end tied to form a small sac.
Rubber band
Candle

Procedure:

Stake out plots one yard square in as many different kinds of locations as possible. The number of plots will depend on the variety of locations that you can find in your school yard. For example:

1. Center of grass plot away from shade trees
2. Near the trunk of a very large shade tree
3. Edge of grass plot near shrub border
4. Within shrub border
5. Unshaded area where grass has been killed by trampling
6. Unshaded area of bare ground that has been cultivated, so that the surface soil is loosened
7. Area near the foundation of the building on the north side, that is shaded for most or all of the day
8. Area near the foundation of the building on the south side, that is exposed to sunshine for most of all of the day.

Examine each of the areas that you have chosen. Teams of students may work together. In a team, the same person should be responsible for testing any particular environmental factor in all of the plots. Why?

In collaboration with Dr. Beth Schultz, Department of Biology, Western Michigan University.

Study the following physical environmental factors in each of the areas: Choose a clear, sunshiny day for your observations. Keep records on a chart such as the one suggested here.

1. Soil hardness. See how far into the soil you can push a pointed pencil or a wooden dowel. Try several places in each plot. Why? Is bare soil harder or looser than soil covered by vegetation? Does the kind of vegetation have anything to do with it? Explore the differences in soil hardness in as much detail as you can. What can you tell about the texture of the soil?

2. Soil permeability: Use a small juice can with both ends removed. Push this cylinder down tightly against or slightly into the soil surface. Do this in such fashion that no water can leak out around the lower edges. Fill the can with water to the same level in each plot. Using a watch with a second hand, determine how long it takes for the water to soak into the soil. Is the time different for different plots. Why? Is there a relationship between hardness and permeability?

3. Temperature at soil surface. Place a thermometer with the bulb at the surface of the soil. If the plot is in sunlight, shade the bulb from the sun. Leave the thermometer in place for five minutes before reading it.

4. Humidity. This factor is difficult to measure in so small an area. The most accurate measurement of humidity is made with a sling psychrometer. What is the nature of this instrument? How does it work? Why is it not possible to use it in your study plots?

For your purpose use two thermometers, one of which has a small piece of woolen cloth fastened around the bulb with a rubber band, or a small sac made of a section of shoe lace pulled over the bulb. Wet the covering of this thermometer. Lay both thermometers side by side with the bulbs just at the surface of the study plot. Fan the two thermometers until the temperature on each stabilizes. What is the difference between the dry and wet bulb temperatures? This is called the wet bulb depression. A great difference indicates that the air is very dry. A slight difference indicates high humidity. There is a gradient between the two extremes. Why is the wet bulb temperature lower?

Relative humidity is expressed as a percent, and is determined from standard tables on the basis of the wet bulb depression. Relative humidity, determined in this way, is more accurate than the wet-bulb depression, but the wet-bulb depression gives you a rough indication of relative humidity. What advantage would there be if you could move the thermometers rapidly through the air, as you would if they were in a sling psychrometer? To what extent do you think that fanning the thermometers gives you this same advantage? Why does evaporation cool the air when it occurs? You may wish to investigate the whole idea of relative humidity further. What can you find out about it?

5. Light. Measure the intensity of the light with a photographic light meter. What is the unit of measurement for light? Relate the intensity of the light to other factors that you measure. To what factors is light intensity related? To what factors does it seem to be irrelevant?

6. Air movement. Determine the direction of the wind as it blows against your face. Light a candle, and by observing the behavior of the flame, estimate the force of the wind--strong, moderate, light, none--(a) at the level of your head, (b) one foot above the ground, (c) as near to the surface of the ground as possible. Record the (c) reading on your chart. Does it differ from the (a) and (b) readings? If so, to what extent? Why?

7. Precipitation. You will have to record this over a longer period. The simplest rain gauge is a straight-sided can. Cut the top out of a fairly large fruit or vegetable can. When you place it in your plot, be sure that the sides are at right angles to the ground. Why? Be sure also that the can is placed firmly on the ground, so that it will not be easily overturned. If you prepare a sufficient number of cans, you can put one in each of your plots. There may not be much variation in the amount of water that reaches the ground in the different plots, but some may occur. From the standpoint of good scientific procedure, the possibility of variation should be checked. Why?

Leave the can in the plot for a week, measuring the amount collected in inches and fractions of inches as soon as possible after each rain or shower. Calculate the total. Leave the can for a longer period. Again calculate the total. Compare your results with the regional rainfall for the same period, as reported by the nearest local weather station. How much do your results vary from the regional rainfall? Why do you think this variation may have occurred?

Simulate the effects of a hard rain on the surface of each plot by sprinkling a given amount of water from a sprinkling can held three feet above the surface. Be sure to leave your rain gauge in place while you do this. How much "rainfall" did you produce? What differences do you observe in the effect of heavy rainfall on different types of surfaces? What about the effect of vegetative growth of different kinds? What conclusions can you draw with regard to soil erosion?

8. Animals. Note numbers and kinds of animals where it is possible to observe these. What about larger animals that would pass through or over the plot without affecting it? Can you observe any of these in the general area? What about signs of animals, such as damaged plants, tracks, or droppings?

9. Plants. Note the kinds of plants present in the plot, the number of kinds, and the number of each kind. If you wish to collect a leaf from each kind of plant for later identification, it is all right to do so. What about larger plants (trees, shrubs, etc.) that shade your plot, or whose leaves or seeds fall on it? What influence do these have? Is this influence the same at all seasons? Do they affect animals and other plants that live in the plot? How? Why?

Conclusions:

What are the major differences in the physical conditions of the plots? What are the major differences in the inhabitants of the plots? How are the inhabitants related to the physical conditions in each case? If you found some of the same kinds of plants and animals in more than one plot, did they differ in size and form? If so, how and why?

Were some kinds of plants and animals more tolerant of habitat differences than others? What effect do you think this might have on the abundance of such species if they were studied over a large area? On their ability to live in different geographical areas? What is it about these organisms that enables them to survive in the places where you found them?

Consider a few of the plants and animals that are more limited in their distribution. What is it about them that enables them to survive where you found them? What limits them to the kinds of places where you found them?

What is meant by microclimate? How is it related to ordinary climate (macroclimate)? Do the microclimates of your plots differ? How? Do they differ from the general macroclimate of the region? How and to what extent? Compare your plots on sunny and cloudy days. What differences do you find? Which of the physical factors that you have studied are affected? Which ones are not?

Further Investigations:

Compare your plots through all of the seasons of the school year. What does this tell you about seasonal change in plant-animal communities?

Project your findings on a continental scale. How does climate vary geographically? How do you think this geographic variation in climate would affect microclimates in the various regions? Why are certain plants and animals found in some regions, and not in others? Are some organisms essentially continent-wide in their distribution? What organisms? Why is this so?

Which of the kinds of plots that you have studied might be considered to be roughly equivalent to overgrazed range or pasture? What kinds of human pressure are exercised to hold down the natural development of plant-animal communities in your school ground? What is their effect? What would happen if these human influences were removed? Fence off a small portion of the school ground, and see what happens. Keep a record of developments over a period of years.

What significance do your findings have for you? How do they help you to understand your environment? Can you think of any practical applications that your findings might have?

City Birds

Introduction:

There is bird life in the man-pounded hearts of our cities if we look for it and if we free ourselves from prejudice against the birds we find there. They are less beautiful, but just as interesting in their habits and habitat relations as the more colorful birds of the suburban backyards, parks, and other semi-natural areas, and those found in forests, forest edges, meadows, and fields. City birds are a part of nature, too. They are members of the man-dominated plant-animal community of civilization, of which man himself is a part. Even though they are not very pretty, and are sometimes dirty, they may be admired for their ability to survive and flourish under conditions where other birds cannot survive. And ability to survive under conditions as they are, is the measure of success in evolution in any place and time.

These city birds are available for everyone to see. Let us look at them, and see what we can find out about them.

Materials, Equipment, and Setting:

The setting is man-created; streets and buildings, such as are characteristic of the city center: the business area, shops and apartments, and some public buildings. There may be small areas of school grounds, churchyard, and public parks.

A pair of field glasses will be a useful aid, but are not a necessity. Bird feeders and bird feed will make your observations more extensive and interesting, but all you really need to do is keep your eyes open, and see the birds around you, and observe their activities.

Most of the birds you see are very common and easily identified. You will see a few that you will need to look up. You should have a copy of Roger Tory Peterson's, A Field Guide to the Birds, published by Houghton Mifflin Company, Boston. This bird guide is useful in North America, north of Mexico and east of the Rocky Mountains. Other similar bird guides are available for other areas where you might be. Many of the city birds are the same wherever you go. Why is this?

Procedure:

Walk through the area that you have chosen to observe. Do so slowly, alone, or if with others, do not talk. Look and listen carefully. Do this several times, at different periods of the day. Repeat your observations on other days. Record your observations in detail.

What birds do you see? How many different kinds? How many of each kind? What are they doing? Where do you see them? On or around buildings? In trees? On the ground? Are the different species seen alone or together? Perching together? Flying together? Feeding together? What kinds of sounds do they make?

Does time of day have anything to do with the number you see, or their activity? Do numbers and activity have any relationship to weather? What about season of the year?

Put up a bird feeder, or scatter feed on the ground or pavement in a spot where you have observed bird activity. Expensive feed is not necessary. Ground corn or dried bread crumbs will do. Sunflower seed will be eaten by some birds. A piece of suet attached to a tree limb or shrub will attract some kinds. What birds do you see feeding. Do they feed together? Is there any evidence of antagonism or rivalry between the different species? Do you observe any species around your feeding station that you did not see before?

What is the origin of the species of birds which inhabit the city center? How many of them are native American? How did the ones which are not native get to this country? How did the species which are native American adapt to the presence and activities of man? Why are some birds (native and introduced) more common in the city than other birds? What is their relationship to man? What would happen to them if man were taken away?

Further Investigations:

Choose another area of observation in a partially open, wooded section of a large park, away from buildings of any kind. Observe birds in the same way and for the same length of time as in the city center. What species do you see? How many kinds are there? Are any species the same as in the city center? Unless you are very well acquainted with a wide variety of species of birds, you will need a bird guide (Peterson or some other) to identify some of them.

Are birds more or less numerous in the semi-natural area than in the city center? What are the different species doing? What are their relationships with one another? What are their relationships to their habitat? With environmental factors such as weather? With the time of day? What are the changes in kinds, numbers, and activity that occur with the seasons? Were there similar seasonal changes among the birds of the city center? Why or why not?

Compare the open forest or forest edge habitat with the habitat of the city center. What are the differences? Are there any similarities?

Why are some people prejudiced against birds like the English sparrow, the starling, and the pigeon? What do you think about it? Are other birds "better" than these? What makes one bird "better" than another? What is the difference between "good" and "bad" birds? "Good" and "bad" insects? "Good" and "bad" plants? What makes an animal or plant "good" or "bad"? Why? How much validity is there to such judgments?

Interrelated Processes in the Human Environment

Introduction:

Modern man depends on a great number of activities and processes in living successfully in the complex environment which he has created for himself. He has come a long way from the time when he hunted for his food or produced it himself, drank from springs and streams, and disposed of his waste materials directly back into the environment.

All of these methods worked very well when man's numbers were few. As his numbers have increased, and he has come to live closer together and in larger groups, they have worked less well, and new, more complex, group methods have been devised for dealing with these problems with greater efficiency. These include methods for food production and processing, water supply and waste disposal, on a mass basis. Individuals in our urbanized world, who live their entire lives without being directly concerned with the carrying out of these activities, depend on others to do these things for them.

All of us, however, are concerned with the problems occasioned when a dry season or a late freeze interferes with some items in our food supply, and when the water supply is reduced as a result of lower than normal rainfall. We are concerned when strikes in food processing industries make certain items temporarily unavailable in the market. And we should be concerned with the larger problems of planning for the use of land and other natural resources in such a way that our use will be in harmony with the orderly processes which take place in the natural world.

Procedures:

It is possible to approach some of these problems within the framework of a science course by planning field experiences in pairs, to observe related phases of human activity necessary to modern living. The two trips, considered together, give students an opportunity to see and understand some of the complexities and interrelationships that are involved.

It is necessary to deal with the matter of surveying the trips and planning them carefully. In planning them, there should be more depth to the activity of the group than simply telling them to "see this", and then "look at that". A set of questions should be prepared related to what is to be observed. These questions should be presented to the group orally by the conductor. Members of the group should then be encouraged to ask questions, not necessarily limiting these to questions that can be answered directly. The conductor's questions should stress relationships, and the students' questions should be led in a similar direction.

Planning the trips, of course, includes such matters as administrative clearance, freeing the class for the extended time spans necessary (usually half-days, although in some cases shorter periods may be sufficient) and arranging for the trips with the people in charge of the facilities to be

visited. Also such matters as transportation, permissions, and an adequate number of adult conductors must be seen to. These problems will vary locally.

An Example of a Pair of Field Trips: The Beginning and End of a City Water System

A trip to see the origin of a city's water supply is followed by a trip to the city's sewage disposal plant. These relationships are seen most clearly in the water supply and sewage disposal operations of a small city, uncomplicated by the industrial use of water and the production of industrial wastes, but some portions and aspects of them can be seen in any town or city, however small or large, where problems of water supply and sewage disposal are dealt with on a municipal rather than a private basis.

It is sometimes possible to see the recording of water use (outflow) over a typical 24-hour period, and to correlate this with a recording of sewage inflow over a similar period. It is also sometimes possible to correlate fluctuations of both water use and sewage inflow with general human activities over the 24-hour period: when people get up, eat breakfast, lunch, dinner, and go to bed, since all of these activities indirectly involve increased water use. Other types of activities, such as week-end washing of automobiles and evening lawn-watering, can sometimes be correlated with water use, if not with sewage inflow.

Other Possible Pairs of Field Trips:

Other possibilities include trips to see the origin and processing of particular kinds of food. These will necessarily vary with the agricultural and other activities of the area. Some of them are: (1) a trip to a farm where beef cattle or hogs are fed, followed by a trip to a meat processing plant; (2) a trip to a dairy farm, followed by a trip to a milk processing plant; (3) a trip to a grain farm followed by a trip to a bakery; (4) a trip to a fruit farm followed by a trip to a cannery or other fruit processing plant.

Still other possibilities involve the production and processing of natural resources other than food. These can be worked out in areas where they are available.

Further Considerations:

If you have worked out previously the laboratory experience involving the pond infusion succession, what relationship do you find between the changes that go on in it and the process of water purification in a reservoir? Between the changes in it and the process of sewage disposal? Any pair of field trips that you may have taken enabled you to look at only two of a long series of related processes. What processes went on before you got your first "look"? Between your first and second "looks"? After your second "look"? What further trips might enable you to see more of the processes in the same series? What about the same questions in relation to pairs of trips in other series? What about interrelationships between different series? To what extent do all of the

activities involved in modern urban living constitute an inseparable network of interrelationships? What about interrelationships between the network of human activities and the network of activities in the natural world of plants and animals? Can the two networks be really separated? What is conservation?

Interrelationships Involving Simple Human Experiences*

Introduction:

No two people ever really perceive the same things. This is because they have different backgrounds of experiences which influence the way they look at the world. This can be shown by the reactions of the members of a group of people to even the simplest things.

Sometimes it is possible to discover why people react to things in the way they do by giving them an opportunity to talk about it. In this way, they will relate their reactions to a very wide range of experiences that they have had, to knowledge that they possess, to their interests, aptitudes, abilities, and ideas. The relationships thus brought to light in any individual, and in a group of which the individual is a part, may well spread across many fields of human activities and knowledge.

Sources of Materials:

A beach having small stones on the surface, or

A gravel pit or rock quarry, or

A railroad track with small stones or gravel for ballast, or

Any other similar location

Procedure:

Note: This experience may be carried on with a group of any size up to about 30. It will not work with a single individual, since a certain amount of group activity in the form of comparison of experiences and discussion is a necessary part of it. Up to a point, the larger the group, the more effective the experience.

1. The teacher should tell the students that they are each to select a stone from the surface of the selected area. They are to select one that appeals to them for any reason at all. For the experience to be most effective, the motives should come entirely from the students. The teacher should be careful not to suggest possible motives such as "pretty," "interesting," et cetera.
2. The group should walk slowly over the surface, and should select their stones after some deliberation. An individual may pick up and discard several stones before finding a single one which he wishes to keep.
3. When all of the individuals in the group have each settled on a single stone, the group may return to the classroom for comparison of their selections and discussion of them. The teacher may initiate the discussion with such questions as, "How many colors do we have represented here?" "How many different shapes do we have represented here?" "Is there a predominant choice of one color (or shape) over others?" "Why?" The members of the group should be allowed an optimal amount of time to compare their selections and discuss them freely with one another.

*In collaboration with Dr. David McKay and Dr. Earl Weiley, Wayne State University, Detroit, Michigan.

4. Members of the group should now be asked to tell why they selected the stone they did. They should also be asked if they have seen a stone selected by some other member of the group that they would rather have had if they had found it, and why. There is much to be said for the development of purposefulness, as well as respect for individual differences, in that each student will come up with a final choice of his own, growing out of and enlarging his own experience. The method of showing and communicating is especially important.

5. Each individual should now be asked to think of what questions he would like to ask about his stone, or the stones belonging to others. What kinds of things would he like to find out about them? What kinds of things could be done with them? What uses could be made of them? Where could one find information about these things? At this point the teacher should feel free to suggest questions at various levels:
 - a. Those to which answers can readily be given
 - b. Those to which answers are not known, but can be found
 - c. Those to which neither students nor teacher know or can find the answers
 - d. Those to which nobody now knows the answer

Questions from the students should be encouraged at all four of these levels.

6. The group should now consider what fields of knowledge have been called into use in connection with the questions asked on the basis of the stones. Have these involved science? Art? Literature? Any others? What interrelationships exist among these fields as shown by the group's consideration of the stones? Could you start with a single stone, and ultimately use all of the intellectual resources of a broadly educated person? How? Why?

7. Now have the class select a single stone by means of a "contest" in which "candidates" are put forward, discussed on the basis of various criteria, and finally one is selected by majority vote. A "runoff" vote between the two top candidates may be necessary. Now a chart should be constructed listing all the questions that might be asked concerning the winning stone, all the areas of knowledge that might be touched by the questions, and the interrelationships between different areas that have been pointed out or are possible. The teacher may participate freely in this final portion of the experience as leader of discussion, questioner, and resource person. The items for the chart may be listed on the blackboard, but will probably outgrow a single boardful.

8. Might cross lines be drawn showing interrelationships between the items listed on the accompanying sample chart?

Further Investigations:

The experience may be repeated, asking the students to select any natural object in the immediate environment other than a stone. The range of possible interrelationships will thus be vastly increased.

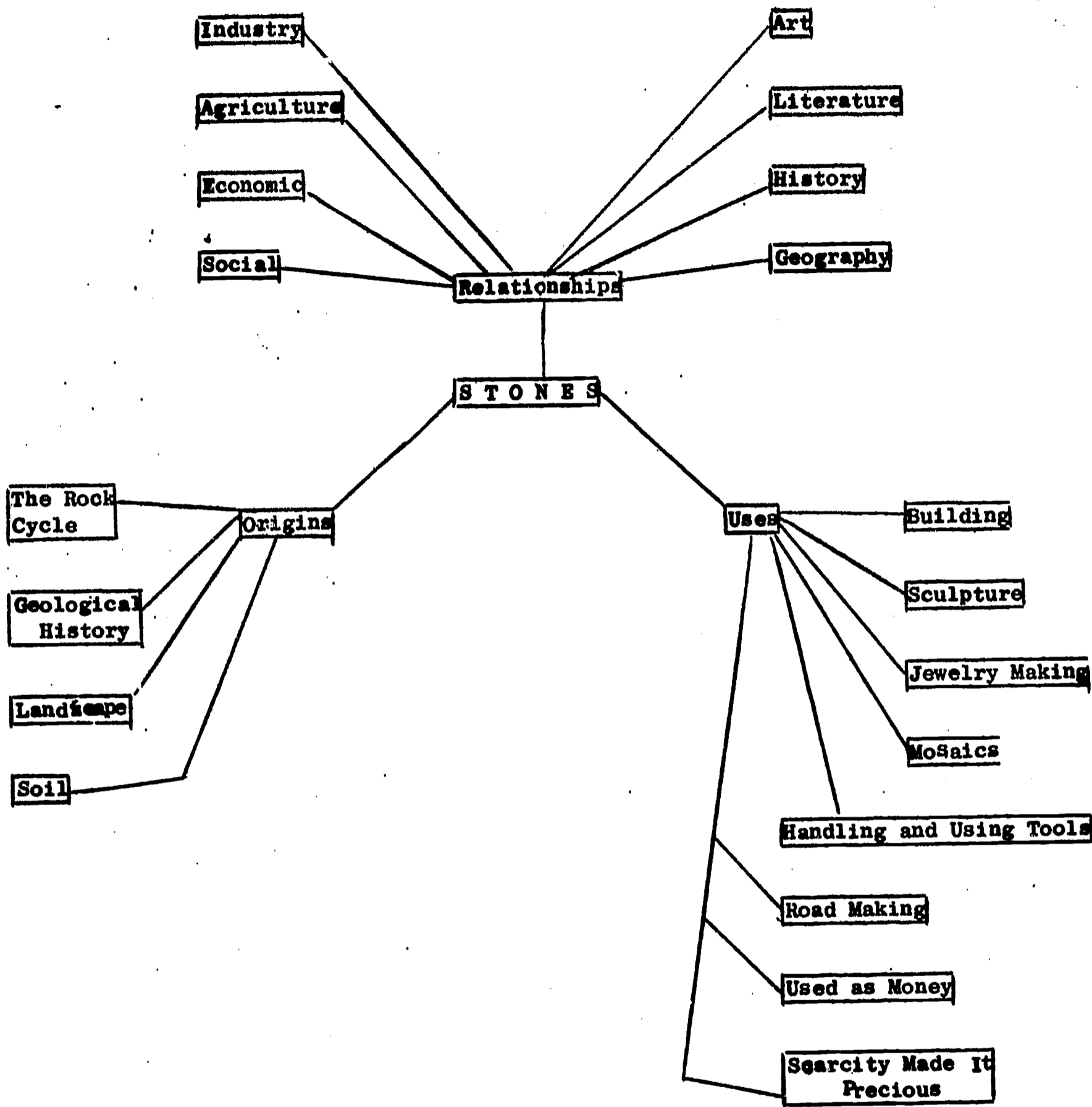

Sample Chart Showing Some of the Relationships
that Might Be Worked Out by a Class*

*Adapted from a chart prepared for an art class by Dr. David McKay, Wayne State University.

XIII

Idea of the Necessary Interaction of Heredity and Environment

1. Idea-Bridge: "Nature or Nurture?"
2. Laboratory Experiences:
 - a. "Plants and Soil Nutrients"
 - b. "Plants and Light"
 - c. "Human Characteristics: Heredity or Environment?"

Nature or Nurture?

When we speak of a characteristic as being "caused by heredity" or "caused by environment", what do we really mean? We are quite willing to recognize that heredity plays an important role in domestic animals and plants. This is true of both the "good" characteristics (those that we like and wish to perpetuate) and the "bad" ones (those that we do not like and try to get rid of through selection). We recognize, of course, that environment plays a part, too. We feed our livestock, train our horses and dogs, and fertilize our fields. We know that heredity and environment necessarily must interact, and we behave accordingly.

When we consider the human species, however, we do not always behave in this way. We like to think that "all men are created equal", regardless of their physical differences. Even though we know that not all people are equally educable, that they have widely differing potentialities and abilities, we like to think that people, in the final analysis, are what their environment makes them. We would like to believe that people have really free choice to make whatever of their lives they wish to make.

Can either heredity or environment act alone? We recognize that physical traits are inherited: eye color, height, body build, curly and straight hair. But are even these due entirely to heredity? A boy inherits the potentiality of growing to be 6 feet tall. In his fifth year, however, he is very ill, and that year he grows only half his normal increment. He never regains the half-inch that he did not grow in that particular year. There is a time and a place for each step in development. A potentiality lost is not made up later. His adult height is only 5' 11½"

Is this true of eye color also? It could be. A child inherits the potential for dark brown eyes. The formation of the dark pigment (melanin), however, might require the availability in the food of a particular chemical trace element, just as the formation of the hormone thyroxin requires iodine in small quantities. If this trace element were not present in adequate supply, the dark pigment would not be formed in the quantities or for the length of time that the child's heredity would have permitted. Therefore, the color of the eyes would be something less than dark brown.

The traits that we would like most to believe are environmental rather than hereditary in their origin are mental abilities and personality traits. These are the areas where it is important that people be "equal". Society can do something about them through education and improved environment and make itself better in the process.

It is difficult, however, to see how even these traits could develop from environment alone. Any behavioral trait is dependent ultimately on the nervous system and/or the endocrine glands. It has to have a physical basis in the microscopic anatomy and cellular physiology of these body systems to exist at all. When we ask what kind of basis, we come finally to the structure, size, number, arrangement, and chemical composition of the nerve cells and the secreting cells of the endocrine glands. All of these characteristics are based ultimately on heredity: what the individual starts out with.

What the individual starts out with may be, and probably is, modified by (1) the embryonic environment, (2) the environment of childhood and youth, and (3) the day-to-day environment in which the person lives. Nevertheless, environment cannot create a trait from nothing. It has to have something as a basis on which to work. Likewise heredity cannot operate in a vacuum. It has to have an environment in which to work.

Plants and Soil Nutrients

Introduction:

The American frontier ceased to exist as a major factor in our national food production in the teen and twenties of this century. At that time the last of the original grasslands that were even marginally suitable for the growing of agricultural crops were plowed. Indeed, some of the prairie land that had been plowed then should not have been plowed at all. With the coming of the dry years of the thirties (1930-1936) a kind of desert called the Dust Bowl developed. This had disastrous results for crops, livestock, and humans.

In spite of the passing of the frontier, however, American agricultural production has increased steadily when permitted to do so. This has been due, in part, to the development of strains of corn and other crops which possess superior heredity. But it has also been due in part to the development of knowledge and practices having to do with the use of fertilizers. Thus our increased agricultural production has been based on a combination of heredity and environment.

We can see the interaction of these two factors in development by watching corn and bean seedlings grow.

Materials and Equipment:

6 flower pots, 6" in diameter

Soil

Sand

Balanced garden fertilizer

Teaspoon measure

Corn grains

Bean seeds

Foot rule

Graph paper

Dissecting microscope or hand lens

Biology or botany textbook

Procedure:

Before filling the flower pots, as directed in (1) below, place a small stone or a shard from a broken pot over the hole in the bottom of each pot. This will facilitate drainage. Then fill each pot to within an inch of the top.

1. Fill two of the pots with sand, two with ordinary garden soil, and two with garden soil to which a teaspoonful of a balanced fertilizer has been added. Measure out the two potfuls of soil for the pots to be fertilized. Pour the two potfuls into a larger container. Add two teaspoonfuls of fertilizer, mix thoroughly, and divide the fertilized soil evenly between the two pots.
2. You have provided three different kinds of environment in which to grow corn and bean plants. Plant two grains of corn in each of the three kinds of pots. Plant two bean seeds in each of the three kinds of pots. If both grains of corn or both bean seeds grow in a pot, remove the last one to germinate or the weaker one.
3. You may assume for purposes of this laboratory experience that all of the grains of corn possess essentially the same hereditary make-up. You may make a similar assumption for all of the bean seeds. Any differences, therefore, which appear in the growing plants may be assumed to be due to environment.
4. Place all six flower pots in a well-lighted area (natural daylight if possible, but not necessarily direct sunlight). Keep the plants at room temperature, and water them regularly; Keep the soil moist but not wet. Many small waterings are better for plants than a few large ones.
5. How long does it take the seeds to germinate and grow to a point where they break through the soil? Do the corn grains or the bean seeds develop first? Do all the seeds of each kind break through at the same time?
6. Take this opportunity to examine the internal structure of a corn grain and a bean seed. If you soak them in water for 24 hours they are easier to dissect. What structures are alike in the two? What structures are different? Why? Examine a longitudinal section of each seed with a low power dissecting microscope or a hand lens. Distinguish the different parts. Look up the names and functions of these seed parts in a biology or botany textbook..
7. Measure the greatest height (from the soil to the tip of the longest leaf, held upright for measurement) of each of the six plants at the same time each day. Record the measurements of each plant on a sheet of graph paper. You may want to try to put the records of all three corn plants on one sheet, and the records of all three bean plants on another. If you can do this it will be easier to compare the growth rates of each kind of plant in the three different environments.

8. Measure and record data on all six plants for at least four weeks after they break through the soil. What are the results at the end of this period? How much difference has environment made?
9. Which is the more important in this case, heredity or environment? Could either one have determined the growth of the plant without the other? Without the basis furnished by heredity (assumed to be the same in this case for all plants of each kind) what would environment have had to work on? Is the relative importance of heredity and environment the same in the case of the bean plants and the corn plants? Is it the same for all characteristics of each kind of organism, or are some characteristics influenced more by heredity and others more by environment?

Further Considerations:

Carry on the experience for a longer period if you can do so. Does the effect of environment increase with a longer time span? Decrease? Remain about the same? Why? Try the same experience with other kinds of plants. Are the results comparable? If the results are different, why do you think this might be so?

Plants and Light

Introduction:

Green plants contain the green pigment chlorophyll. This pigment is able to capture the energy of sunlight and utilize it to combine carbon dioxide and water into simple sugars (carbohydrates). These are energy-containing compounds which can be used by the plant either for manufacturing other complex organic substances (fats, proteins, nucleic acids) or as a source of stored energy for carrying on the physical and chemical activities that take place in the plant's cells. Utilizing the energy of sunlight, through the agency of chlorophyll, for the manufacture of food is called photosynthesis.

Animals like ourselves, and colorless plants such as mushrooms, molds and most bacteria, also base their life processes on the food materials which are manufactured by green plants. We need carbohydrates, proteins and fats as foods. Life on earth depends basically on the process of photosynthesis.

Some strains of green plants have mosaic patterns on their leaves, with colorless areas or spots which lack chlorophyll. Other plants may carry a gene (hereditary factor) for total absence of chlorophyll. This characteristic, of course, is not survivable in nature unless the plant lives as a parasite on another plant, as a few species do. Free-living plants which show this characteristic die as soon as the food material is used up which is stored in the seed from which they grow. However the gene for absence of chlorophyll (albino gene) is carried as a recessive in some apparently normal plants, and is therefore able to persist in a racial stock by being carried along with a gene for normal chlorophyll. Mosaic patterns are also determined by a kind of heredity, but these plants have enough chlorophyll in their leaves to survive.

Green plants generally possess other pigments in addition to chlorophyll. These include yellows, reds, and purples. In the fall in temperate climates the green pigment breaks up first, and the other colors are left. This is why some trees and shrubs develop "autumn coloration" in their leaves before they are shed. In some plants these yellow, red and purple pigments are present to a sufficient extent that they show through the green at all seasons. Thus we have potted plants and even trees and shrubs in which yellow, red and purple coloration is mixed with green throughout the season. These are used for ornamental purposes. Their colors are also determined by hereditary factors.

In this laboratory experience you will have an opportunity of observe the operation of hereditary color factors in plants grown in different amounts of light.

Materials and Equipment:

12 flower pots, 6" in diameter

Albino corn grains (These can be obtained from General Biological Supply House, Inc., 8200 South Hoyne Avenue, Chicago 20, Illinois, or other biological supply company.)

Normal corn grains

Rooted cuttings from Coleus plants showing as many colors as possible (These can be obtained locally from any greenhouse. Coleus is a common potted house plant. It is often called simply "foliage plant".)

Millimeter rule or foot rule

Procedure:

Before filling the flower pots as directed in (1) below, place a small stone or a shard from a broken pot over the hole in the bottom of each pot. This will facilitate drainage. Then fill each pot to within an inch of the top.

1. Fill 12 pots with garden soil. In four of them plant three grains each of albino corn. In four of them plant three grains each of normal corn. In each of the remaining four, plant one rooted cutting of Coleus. Take the cuttings from a plant showing as many and as bright colors as possible. Take all four cuttings from the same plant. Why? (Cuttings will normally root in ten days to two weeks if placed in water.)
2. Place one pot of each kind of planting in each of the following four environments with respect to light:
 - a. Direct sunlight (as of south window)
 - b. Indirect daylight (as of a north window)
 - c. Partial light (as of a north window)
 - d. Total darkness (as of a closet)
3. Keep the soil moist but not wet. Be sure that all pots are subjected to the same conditions of temperature.
4. Observe all of the pots daily. Record any data which appear to be significant.
5. How long does it take the corn seedlings to break through the soil? Is there any difference in this respect between the albino corn and the normal corn? Is there any difference in either type of corn between pots exposed to different conditions of light.

6. What about the rate of growth of the corn seedlings (both types) in different conditions of light?
7. Is there any difference in the extent of development of green pigment in the normal corn under different conditions of light? Why or why not?
8. How long does the albino corn live? Is there any difference in the time of its survival under different conditions of light? Why or why not?

The potentiality for development of green pigment or the lack of it is a part of the heredity of the corn plants. What is the role of environment in this case? Is it possible for the heredity of the corn plant to produce green pigment without interaction with the environment? To what extent is this possible, if at all? Why or why not? Is it possible for the environment of the corn plant to produce green pigment without interaction with heredity? To what extent is this possible, if at all? Why or why not? Is it possible to determine in the case of the development of green pigment in the corn plant, which is the more important, heredity or environment? Which do you think is the more important? Why?

9. Is there any difference in the rate of growth of the Coleus plants under different conditions of light?
10. Does the amount of light have any effect on the development of pigments in the Coleus plants? Is there any difference in the effect of the amount of light on the different pigments, or are all pigments affected in the same way and to the same extent?
11. Devise hypotheses to explain any differences which you have been able to observe in the Coleus plants grown under different conditions of light, or the lack of differences. Do this in terms of the interaction of heredity and environment. Which do you think is the more important in this case? Could either have functioned without the other?

Further Considerations:

Try the effects of other environmental factors on the Coleus plants. Does fertilizer have anything to do with the development of pigments? How about temperature?

Secure a specimen of a plant having leaves showing green and white, mosaic patterns. Try growing cuttings from this plant under different conditions of light. Does amount of light have any effect on its growth? Try other environmental factors. Do the white areas differ in size under the influence of different environmental factors? Do you think it might be possible to set up an environment sufficiently favorable that the white areas would disappear altogether? What is the method by which the mosaic pattern of leaves is inherited?

Human Characteristics: Heredity or Environment?

Introduction:

There are some human characteristics which are readily recognized as having a hereditary basis: eye color, curly hair, facial features, height and body build, for example. Others, such as susceptibility to disease, are less widely accepted as being related to heredity. Still others, including personality traits, general mental ability, and various special aptitudes, are thought by many people to be largely, if not wholly, due to environment.

In this laboratory experience we will examine a physical trait, and ask ourselves if environment could in any way influence its expression. Then we will examine a trait of behavior and ask ourselves if it could have a hereditary basis.

Materials and Equipment:

No materials or equipment are necessary for the first part of this laboratory experience. For the second part the following are necessary:

Filing cards, 3" X 5"

Tags

Scissors

Envelopes

Millimeter rule

Procedure:

The inheritance of eye color in humans is ordinarily presented as being based on two kinds of genes or hereditary determiners: brown and blue. There is a single pair of these. The pair may consist of two brown genes, two blue genes or one brown and one blue. The brown gene is stronger than the blue, and is dominant over it when the two are present together. Therefore two browns or a brown and a blue will produce brown, while two blues will produce blue. Although there is no question that this pair of genes exists, and furnishes the principal basis for the determination of eye colors, is this the whole story?

The color of the eyes in humans is due principally to one pigment, melanin. This is a dark pigment which is found also in hair and skin. In all people except albinos (those who carry a gene for total absence of color), the melanin is deposited in the iris of the eye from a point in embryonic development to an end point which differs in individuals. Sometimes the process of deposition is completed before birth. Sometimes it continues well into childhood. Heredity serves to determine the rate and timing of the process of pigment deposition. Darker eyed persons are those in whom the process went on faster and/or for a longer time.

1. Observe closely the colors of the eyes of all members of your class. Is it possible to classify all of them as either "brown" or "blue"? Try to put them into the smallest possible number of color groups consistent with reality. How many color groups are necessary? Try out your color groups by attempting to classify the same number of persons outside your class. Do you find any individuals who do not fit into any of the groups? If you do, you will need to revise your classification, and possibly create a new color group. Continue to try out and revise your classification until you are sure that you can use it to classify any person whom you might meet.
2. Now line up the members of your class in such a way as to form an eye-color gradient, from the person with darkest eyes to the person with lightest eyes. Can you draw a line between "brown" and "blue" on the gradient? Where does "brown" stop and "blue" begin? Is there a gradient within the brown range, and within the blue range (some darker and some lighter)? What about the color groups which you have identified between brown and blue?
3. Do you think that a single pair of brown-blue genes is sufficient to account for human eye color? Would it be possible with a single brown-blue pair to have colors other than one shade of brown and one shade of blue? One possible explanation would be the existence of modifying genes (intensifying genes and diluting genes). Another would be the influence of the environment, modifying the action of a single pair of genes. Which do you think is the most likely explanation? Why?

The second part of the experience has to do with the development of a simple skill.

1. A simple puzzle should be prepared for each member of the class. All puzzles should be made according to the same pattern. Each one consists of a 3" X 5" filing card cut into 10 pieces. (This is the same kind of puzzle that was used in the laboratory experience entitled A Simple Learning Curve.)

The 10 pieces into which the card is cut should be approximately the same size, and of as many shapes as possible. The cuts, however, must all be along straight lines. It is best to draw lines (lightly with pencil) to indicate the cuts before doing the cutting. The pieces of each puzzle should be placed in an envelope and given to the students, but neither pieces nor envelopes should be marked in any way.

2. A series of numbered tags, beginning with (1), should be prepared, equal to the number of students in the class. These should be shaken up, and each member of the class should draw a number. This will determine his participation in the first series of contests.

3. Students will contest in pairs. As many pairs may contest at a time as there are umpires to watch them. Students who are not contesting at a particular time may serve as umpires. In each contest the student who gets the puzzle together first is the winner.
4. Each student will contest three times in each series of trials. For the first trial, the pairs numbered (1) and (2), (3) and (4), (5) and (6), (7) and (8), and following, will contest. For the second trial, numbers (1) and (3), (2) and (4), (5) and (7), (6) and (8), and following, will contest. For the third trial, numbers (1) and (4), (2) and (3), (5) and (8), (6) and (7), and following, will contest. Students losing all three of the contests will retire from the game.
5. The numbers should be collected at this point. The remaining students who are still in the game will draw new numbers in a series beginning with (1). They will repeat the process, each contesting three times in the same numerical order as before, using the same puzzle. Again the three-time losers will retire from the game.
6. Additional contests following the same pattern will continue until all students except one have been eliminated. This remaining student will be declared winner. If more than one class group has been engaged in the same laboratory experience, the "champion" of one class group may contest with the "champion" of another. This may be done if the same puzzle has been used in both classes. If different puzzles have been used, the situation would not be comparable. Why not?

How is this laboratory experience like competition in business or politics? How is it different? Is success in these fields based in part on inherited ability? Or is it entirely a matter of hard work? Or luck? If a part of it is based on good home background, how much of this, in turn, is due to inherited ability in the family line?

How much do you think inherited ability had to do with winning this contest? How much do you think environment had to do with it? What kind of hereditary factors, if any, could have been operating? How do you think environment could have operated to contribute to the result? Which do you think was most important, heredity or environment? Why?

Further Considerations:

What about other human traits: Susceptibility or resistance to respiratory disease? Heart disease? Cancer? Mental disorders? What about personality traits: High temper? Antisocial traits? Criminal tendencies? What about special abilities: Musical ability? Artistic ability? Mechanical ability? Mathematical ability? Facility with languages?

To what extent do these traits and others like them have a hereditary basis? To what extent are they due to environment? Is it possible for any traits of this type to develop without some interaction of both heredity and environment? Does the relative importance of heredity and environment always have to be the same in the case of different traits?

XIV

Idea of Differential Rates of Processes

1. Idea-Bridge: "Development of Form Through the Operation of Differential Rates of Processes"
2. Laboratory Experiences:
 - a. "Development of a Chick Embryo"
 - b. "Development of a Bean Plant"
 - c. "Differential Growth Rates in Humans"
 - d. "Differential Rates of Processes in the Development of the Landscape"

Development of Form Through the Operation of Differential Rates of Processes

If a city is growing through the developmeent of residential suburbs on the southwest side, in the direction of the prevailing wind, and growing more slowly or remaining static in other directions, it will not be long until the demand for new schools, new sewers, new water lines, new arterial streets and highways, and pressure for the sale of new products in the southwest section will change the whole geographic balance of the urban area. Furthermore the map will show a large bulge of urban development on the southwest side. The shape of the city on the map will have changed.

If a business enterprise finds that one particular line of its products is growing rapidly in popularity and sales volume, while other lines are increasing less rapidly, remaining static, or even showing a loss, it will not be long before the major effort of the company will be diverted to the popular line, and the whole aspect of the business will be changed. If you discover that you do exceptionally well in science and mathematics, and less well in English and history, you will probably take all the science and mathematics courses you can get, and take only as much English and history as is required. You will probably major in science and mathematics in college and go into scientific research or teaching, or some science-related profession. The whole future course of your life will have been determined by your aptitude and growth in a particular direction.

Differential rates of increase affect the development of populations and plant-animal communities. A species does not usually become extinct through all of its members in a particular generation being killed off or starving to death or dying of disease. This can happen, but usually it does not. More frequently a species becomes extinct because over a period of many generations it multiplies less rapidly than other species that are its competitors. Even if many of the mature individuals of a species are killed, this alone is not usually a cause of extinction. It would be difficult to make house mice or English sparrows extinct, no matter how many mature individuals were destroyed. Those that were left would multiply rapidly and fill the gap.

The faces of continents are sculptured by differential rates of the rising of mountain ranges and the sinking of coast lines. These processes interact with differential rates of erosion and deposition, and wear down mountains and build deltas and alluvial plains. On a smaller scale in both space and time differential rates of some of these same processes can be seen at work in any eroded field.

Differential rates of growth play a major role in the development of animal embryos and the shaping of plant bodies. The arms, legs, head, general body proportions, and most internal organs in animals, and the leaves, branches, flowers and various special structures in plants are formed by differential growth rates. Many of the characteristics that help to determine an individual's appearance depend on differential rates of physiological processes. An example is the depositions of colored pigments in eyes, skin and hair. Some differential rates continue throughout life. Compare the body form of an old person with that of a young person of the same sex. The differences that you see are the result of differential rates of processes that have operated slowly but steadily through the years.

The Development of a Chick Embryo

Introduction:

The chick is standard material for the study of embryonic development in a vertebrate. The early stages of all vertebrate embryos are similar, and the chick embryo is easy to work with and observe. Furthermore, its incubation period is short (three weeks). By starting a series of eggs incubating at the same time, and opening one each day, it is possible to see the progressive development of body form. This is particularly interesting during the first four or five days of development. During this period the basic body form is attained and the major organ systems begin to take shape. After this, the remainder of embryonic development is largely a matter of growth in size, and changes in the relative proportions of body parts.

The sculpturing of the embryo, both externally and internally, takes place because the cells in a particular area multiply faster and/or for longer time than the cells in surrounding areas. Therefore, the rapidly growing cells "pile up".

This results in a limited number of growth forms. Cell growth generally takes place in layers. When cells in a layer grow faster or longer at one point than at surrounding points, the resulting cell proliferation may take the form of a pocket inward, a pocket outward, a fold, a thickening, or a migration of the newly formed cells into other areas. These five processes result in the formation of noses, ears, arms and legs, fingers and toes, the shape of the head, the shape of the body, and other sculpturing of the external form of the embryo. Internally, the same growth forms result in the formation of liver, lungs, stomach, pancreas, kidneys, reproductive organs, brain, the internal portions of the sense organs, heart, blood vessels and blood, and other internal structures.

Other developmental processes depend on the formation of specific chemical compounds, such as the pigment melanin that darkens hair, eyes and skin. Here the rate at which the pigment is secreted and the length of time during which it is secreted determine how dark the hair, eyes and skin become. The dark-complexioned, dark brown-eyed person, with dark brown or black hair, is one in whom the formation of melanin proceeded faster and/or for a longer time than in the person with lighter brown or blue eyes, light brown or blond hair, and fair skin.

The results of the operation of differential growth rates can be seen readily in the developing chick embryo during the first few days of incubation.

Materials and Equipment:

Incubator capable of maintaining a temperature of 103 degrees Fahrenheit

Fertile chicken eggs (These can usually be obtained from a hatchery.)

Low power, wide field dissecting microscope (A hand lens may be used, but it is less satisfactory.)

Syracuse watch glasses

Dissecting scissors with sharp points

Prepared slides, whole mounts, of 24 hour, 48 hour, 72 hour, 96 hour and 120 hour chick embryos (While the experience can be carried on without these, they add greatly to it.)

A textbook of biology or embryology containing labeled pictures or diagrams of chick embryo whole mounts.

Procedure:

1. Place fertile hen's eggs in a standard egg incubator (103 degrees Fahrenheit). Start a minimum of 15 eggs. This will include three eggs each for the 24 hour, 48 hour, 72 hour, 96 hour, and 120 hour stages. Starting three eggs for each of the stages you wish to observe allows a margin for infertility and mistakes in technique. Remember that although we speak of "stages", the development of the embryo is a continuous process.
2. Open at least one egg at the same time each day for five days. These eggs will represent the developmental stages indicated above. To open an egg, proceed as follows:
 - a. Place the egg to be opened in a Syracuse watch glass. Ordinarily, in the early developmental stages, the embryo floats on top when the egg is laid on its side.
 - b. Bore a small hole through the egg shell with the sharp point of a pair of laboratory scissors, a little to one side of center as the egg lies.
 - c. Then, with the scissors, cut an oval window about one inch across through the shell on the side of the egg lying uppermost.
 - d. The oval piece of egg shell that is removed may be placed at the side of the egg in the watch glass to wedge it and hold it steady for observation.
3. Observe the freshly-opened embryo each day with the unaided eye, and with a hand lens or a low power dissecting microscope. It is interesting to note that in observing living chick embryos with the unaided eye, you are following in the footsteps of all of the early embryologists from Aristotle (in the 400's B.C.) to William Harvey (in the 1600's A.D.) They likewise incubated eggs and opened one each day to observe its development.
4. Compare the living embryos at each incubation stage with stained, mounted specimens of the same stage. Look up the names of the structures that you see in a biology or embryology textbook.

5. Note particularly those structures which can be seen in the stained specimens that are visible in the living embryos also. In general, what would you say as to the time of appearance of particular structures in the stained as compared to the living specimens? Why?
6. What is the earliest structure that is visible in the living embryo? At what stage do you see it?
7. When does the beating heart first appear? At what stage can you see the heart structure in the stained embryo? Look up the stages of the development of the heart in a biology or embryology text. Explain the formation of the heart in terms of differential growth rates.
8. Note the progressive development of body structures along the embryonic axis (the head-to-tail axis of the body). Which end of the axis develops most rapidly? Note the appearance of brain and sense organs. At what stage do they appear? Compare the living and stained specimens in this regard. Read about the development of nervous system, brain, and sense organs in a biology or embryology text. Explain what you have seen and read about it in terms of differential growth rates.
9. Note the development of wing buds and limb buds. Again compare stained and living specimens. Explain in terms of differential growth rates.
10. Note the twisting of the body to one side, beginning at the head end. At what stage does this begin? In what position is the embryo lying on the yolk in the early stages? In the later stages? Why do you think this takes place? Explain how it takes place. Explain how it takes place in terms of differential growth rates.
11. Note the growth of the yolk sac out over the yolk. Read about the development of the yolk sac and other extra-embryonic membranes in a biology or embryology text. What is the function of the yolk sac? Of the other extra-embryonic membranes?
12. Read in a biology or embryology text about the development of liver, lungs, pancreas, and other internal organs. How are the blood vessels and blood formed? What is the role of differential growth rates in the formation of internal organs?
13. Identify in your study of the development of the embryo, the occurrence of inpocketing, outpocketing, folding, thickening, and cell migration. Which of these processes took place in the formation of each of the structures that you have observed or studied about?

Further Investigations:

Follow the development of the chick through to hatching. This usually takes place on the twenty-first day of incubation. Note in particular the growth in size and changes in body proportions that take place after the fifth day. Account for these in terms of differential growth rates.

Study the stages in the development of a human embryo in a book on human embryology. If a collection of preserved human embryos is available in a museum to which you have access, observe these. Compare with the developmental stages of the chick during the first five days. On the basis of the length of time that it takes a human embryo to develop (10 lunar months of 28 days each), what ages of the human embryo would correspond to the five stages of the chick that you have studied? Compare them at these points.

What is the evolutionary significance of the yolk in the eggs of chickens and other birds? Do any other animals have large-yolked eggs? How can the eggs of humans and other mammals develop with only a minute amount of yolk material in the egg?

Within the last few years there were news stories concerning the effects of a drug, thalidomide, which when taken by the mother during a particular period of pregnancy, caused babies to develop with defective arms and legs. In terms of differential growth rates, what do you think was the probable action of this drug during the development of the embryo?

Development of a Bean Plant*

Introduction:

The same basic growth processes take place in both plants and animals. Cells divide by the process of mitosis, involving an equal distribution of the materials of heredity from a mother cell to two daughter cells. Cells, however, do not always divide at the same rate. The growth rates of various portions of the body of a many celled plant or animal are under the control of chemical substances called enzymes and hormones. These are produced by the cells themselves. The production of these substances is, in turn, under the control of hereditary factors.

As a result of the operation of differential growth rates, where one portion of the body of a plant or animal grows faster and/or for a longer time than the surrounding parts, the body form is sculptured. Branches, leaves, and flowers; arms, legs and head take form.

In this laboratory experience you will have an opportunity to observe the growth of a common plant from this point of view. You have seen plants grow all your life, but you have probably never thought about their growth in this way.

Materials and Equipment:

- Flower pots, 6" in diameter
- Garden soil
- Bean seeds
- Millimeter rule
- Graph paper
- A biology or botany textbook

Procedure:

1. Plant one bean in each of three six-inch flower pots, filled to within one inch of the top with garden soil.

Note: Before filling the pots with soil, place a small stone or shard of broken pot over the hole in the bottom of each to facilitate drainage.

2. Place the pots in a warm location in good light. Water regularly. Keep the soil moist but not wet. How long does it take the bean seedlings to break through the soil? Do all three break through at the same time? Keep a record.
3. How does the break-through take place? Describe the behavior and growth of the seedlings in terms of differential growth rates.

* In collaboration with Miss Paula Peck, student in the Biology Department, Western Michigan University,

4. What are cotyledons? Look them up in a biology or botany textbook. Is their unfolding a matter of growth through cell division or some other process? What is the first structure to develop after the unfolding of the cotyledons? Describe its development in terms of differential growth rates.
5. Measure developing leaves at the same time each day with a millimeter rule. Record measurements to the nearest millimeter. Measure the leaves from the time of the earliest appearance of the leaf until growth ceases. Measure both length and width of each leaf. Keep a record on graph paper of the successive measurements of each leaf. Measure and record measurements of a large enough number of leaves to answer the following questions:
 - a. Do all leaves grow at the same rate?
 - b. Is the rate of growth in length and width of leaves the same?
 - c. Do the proportions of different parts of the leaf change from the time of its appearance until its growth is complete?
 - d. Does it take all leaves the same length of time to reach their final size?
 - e. Is the final size attained by all leaves the same?

Set up a hypothesis to explain any differences that you find in the growth of different leaves, and different parts of the same leaf, in terms of differential growth rates.

6. Measure the height of each of the three plants every day (from the soil to the tip of the uppermost leaf, held upright). Record the measurements of each plant on a sheet of graph paper. Are there differences in the overall growth of the three plants? Set up a hypothesis to explain you observations.
7. Seven days after planting the seeds measure the height of the bean plant which is growing most rapidly. Carefully mark the stem of the plant at intervals of 1 centimeter. Measure and mark the plant every 5 days. Do the marks all remain 1 centimeter apart, or does growth alter the distance between them? Does growth appear to occur at the same rate over the entire length of the stem? Do some parts grow while others do not? Can you find a point of most rapid growth on your plant? Where is it? Set up a hypothesis to explain your observations. According to your hypothesis would initials carved on a tree get farther from the ground as the tree grows taller?
8. Measure two branches on each plant, and keep a record of the growth of each branch each day. Measure from the main plant stem to the tip of the outermost leaf held parallel to the branch. Is there a difference in the rate at which branches grow? On the same plant? On different plants?

9. Describe the development of the bean plant in terms of differential growth rates. How is the general shape of the plant determined by differential growth rates? What part would you say differential growth rates play in the development of plants in general?

Further Considerations:

Carry on the same laboratory experience using a tomato plant grown from the seed. Observe a climbing plant, such as a gourd vine or a grape vine. These plants have twisted tendrils for holding onto the object of attachment. Study the tendrils closely and watch their development. Explain their development in terms of differential growth rates.

Observe the growth processes involved in the development of a flower. Explain these in terms of differential growth rates.

Differential Growth Rates in Humans

Introduction:

We know individual humans better than we know individuals among other animals. Also man is more variable than most other species of animals. Therefore we are very conscious of the physical differences that distinguish humans from one another. These include body size and shape, skin color or complexion, eye color, hair color, shape of face, size and shape of nose, and other differences.

These characteristics develop as a result of the operation of differential rates of growth and other processes. The cells in one area of a developing individual grow faster and/or for a longer time than the cells in surrounding areas. Because of differential growth, the total proportions of height and breadth of the body come to differ in different individuals. Arms and legs are formed, and fingers and toes on the ends of them. Chemical substances such as melanin (the pigment which produces dark color in eyes, hair and skin) are produced more rapidly and/or for longer time in one individual than in another. As a result of all of these differential rates operating over the period of development, the form and appearance of individual humans is sculptured, and various distinguishing characteristics are formed.

In this laboratory experience you will have an opportunity to observe some simple examples of differential growth rates and their results in humans.

Materials and Equipment:

Graph paper

Plain paper

Millimeter rule

Filing cards, 3" X 5"

Procedure:

1. Measure the growth of your finger and toe nails over a period of time. Record the growth of the nail on each finger and toe on both hands and both feet on graph paper. Students may work in pairs if desired, with one to grow nails and the other to measure and record. Proceed as follows:
 - a. Trim each nail as short as possible for the start of the experience.
 - b. Measure the length of the nail from the cuticle at its base to its upper edge. Use a narrow strip cut from a 3" X 5" filing card. Mark the length of the nail as accurately as you can on the strip with a sharp pencil. Use a fresh strip for each measurement.
 - c. Measure the marked length on the strip of card with a millimeter rule. Record the measurement to the nearest full millimeter.

- d. Measure the length of each nail once a week, on the same day each week.
 - e. Continue the experience for as many weeks as you can. The longer you do so, the more interesting your results will be.
2. Try to answer the following questions:
- a. Do all of your nails grow at the same rate?
 - b. Do your toe nails grow at the same rate as your finger nails?
 - c. Do the nails on the right and left sides of your body (finger and toe) grow at the same rate?
 - d. Do all of the nails on any one hand or any one foot grow at the same rate?
 - g. Explain any differences you find in terms of differential growth rates.
3. Compare your results with those obtained by other members of the class. Are there differences between the growth rates of the nails of different individuals? Between boys and girls? Between children and adults?
4. Draw outline profiles of the noses of ten adult men or women. Try to find as many different nose shapes as possible. Do the same thing for the noses of ten children your own age. In which group do you find the greater differences? Why? In development, do all parts of the nose grow at the same rate? Explain the differences in the shapes of noses that you have observed in terms of differential growth rates.
5. Look at your face in full front view in a mirror. Are the two sides of your face alike? With a piece of stiff paper, cover first the left side and then the right side of your face. Are there any differences between the two sides? Imagine each side extrapolated to make a complete face. Would you be "two people"? Which side do you like the better? Explain any differences between the two sides in terms of differential growth rates.

Further Investigations:

Observe other differences in a series of human subjects: shape of hands, length of fingers, shape of head, general body build. Explain these in terms of differential growth rates. Explain the differences in body proportions of man and women in terms of differential growth rates.

Differential Rates of Processes in the Development of the Landscape

Introduction:

Not only the form and appearance of living things, but also the form of the landscape is shaped by differential rates of processes. In the case of the landscape many of the processes go on over very long periods, in some cases centuries, even thousands or millions of years. In some cases however, we can see them going on around us on a small scale if we look for them.

Sand dunes are formed by the wind, and their shape may change over a single season, due to the direction of the wind, breaks in the surface, or the presence of barriers to the force of the wind. Streams tend to erode their banks on one side and deposit sediment on the other, due to the diversion of the current toward one side or the other. In old drainage patterns this process of differential erosion and deposition causes streams to develop meanders that wander back and forth across broad, flat valley floors.

Erosion cuts more rapidly into softer material than into harder material, thus sculpturing the surface of the land. Some rocks, like limestone, erode rapidly. Others, like granite, erode very slowly. Sometimes you can see the effects of this differential erosion on a stone if it is made of different kinds of materials.

Once you have this idea as part of your thinking, you can continue to observe the effects of differential rates of processes in the formation of the landscape wherever you go. At this time you can see some small examples.

Materials and Equipment:

A series of dirt piles of various ages, such as you might find around a construction project

A field or road cut, in which erosion has taken place, or is actively taking place

A stream with banks of mud or sand

A stream with a rocky bottom

Procedure:

1. Observe the process of erosion on a dirt pile, or in a field or road cut. Is erosion occurring at the same rate in all places? If it is not, see if you can figure out why it is not. Consider degree of slope, relative hardness of material, and any other factors that are apparent.
2. Find a rock or pebble on the side of an eroded channel. What effect has it had on the erosion process?
3. Find a place where the force of the moving water has been turned aside by an obstruction. How has this affected the rate and direction of the erosion?

4. Observe a stream with banks of mud or sand. Do you see any indications that erosion is going on on one side and deposition on the other? Correlate this with the direction of flow of the main current of the stream. See if you can find any other reasons for the differential erosion and deposition that you observe. What do you think will eventually happen to the course of the stream? What are oxbows? Oxbow lakes? How are they formed? How is it possible to distinguish a stream that belongs to an old drainage pattern from one that is part of a young drainage pattern? What kind of drainage pattern is characteristic of the area where you live? Is it old or young? Why do you think so? How old is it? What is the history of it?

5. Observe a stream with a rocky bottom. Do you find any evidence that some of the rocks in the stream bottom have eroded more rapidly than others? Are they all the same kind of rocks? Is the differential erosion due to variations in the force of the current? If so, what caused these variations? What are potholes in the bottom of a rocky stream? Do you find any? How are they formed? Do you find any round stones? What has made them round? See if you can find any stones in which difference in hardness of the materials of which they are formed has kept them from becoming completely round. Can you identify any other factors that might be responsible for their shape?

Further Investigations:

Set up an experimental area on your school ground with a dirt pile containing stones and other possible obstructions to erosion. Observe this dirt pile undergoing erosion for a sufficiently long period for differences in rate to show themselves. What conclusions can you draw as a result of your observations?

As you travel, watch for the operation of differential rates of processes in landscape formation. Try to project them into the future and figure out what the landscape will ultimately come to look like as a result of their continued action. How long do you think it will take? See if you can find any differential rates of processes in operation other than the ones that have been pointed out in this laboratory experience.

If you are near a sand dune area along the shore of a large lake or the ocean, observe the effects of the wind on dune formation and shape. In what kinds of places is the sand being blown away by the wind? In what kinds of places is it being deposited? See if you can figure out why these processes are happening as they are. Explain the form of the dunes area as you observe it in terms of differential rates of wind erosion and deposition. What is the relationship of what you are seeing here to streamlining in the designing of automobiles and airplanes? What is a wind tunnel and how is it used? Why do space ships and satellites not need to be streamlined?

XV

Idea of Tools as Extensions of Man's Body and Its
Capabilities

1. Idea-Bridge: "Thinking About Tools as Extensions of Man's Body and Its Capabilities"
2. Laboratory Experiences:
 - *a. "Extending Man's Body with Tools"
 - *b. "Extensions of Man's Body: Simple Machines"
 - *c. "Extensions of Man's Body: Complex Machines and Utilization of Outside Energy"
 - *d. "Extensions of Man's Body: How They Have Evolved"

*Included in Bulletin No. 313, NDEA Title III, Open-Ended Laboratory-Centered Science for Grades 7-8-9. Michigan Department of Public Instruction, Lansing, Michigan, 1965.

Thinking About Tools as Extensions of
Man's Body and Its Capabilities

In the series of laboratory experiences which this statement introduces, we will be using the word "tool" in several related but different ways. We have to do this because there is no other word in the language which says exactly what we want to say, and we do not feel that we would be contributing to your understanding of the idea that we are trying to present by inventing a new word. (Scientific terms, in many cases, are such invented words.)

We have to use the word "tool" to refer to certain simple devices which man uses in his work: hammers, saws, jacks, scissors, crowbars, et cetera. Most of these are adaptations of one or more of the simple machines that man discovered and began to use very early in his cultural development. We again use the word "tool" to refer to certain much more complicated devices such as typewriters, draftsman's tools, microscopes. These are what we mean when we say that a secretary, or draftsman, or laboratory technician, or other kind of specialist "knows how to use the tools of his trade".

In these laboratory experiences we also use the word "tool" in a much wider sense, simply because there is no other word that will get the job done. A "tool" in this sense is anything that is used to solve a problem, or to meet a challenge posed by the environment. It is any kind of device or expedient, physical, social, or mental, which enables man to adjust to, utilize the properties of, or overcome his environment, where this is necessary for his continued existence, or for his continued success or satisfaction. We have now "sharpened" the word "tool" by giving it a special definition. (Scientific terms, in many cases, are such "sharpened" words.)

Tools constitute extensions of man's body and its capabilities. This concept may be expanded to include the outside sources of energy that are necessary for the operation of the complex machines which are a part of modern civilization. The energy of man's body was first supplemented by that of domestic animals, and later by that of wind, falling water, burning wood, fossil fuels, and now nuclear energy. The amount of outside energy utilized has increased progressively as machines have become more complex, and as the tasks for which they are used have increased in size and complexity.

Tools can function as extensions of arms and legs, extensions of communication organs and sense organs, and extensions of other capabilities, depending on the nature of the tool and the function for which it is used. Clothing and housing are tools that extend man's capabilities of living (or even surviving) in the face of particular kinds of environmental challenges. Spoken and written language are tools that extend man's capability of communicating in both space and time. Modern devices for rapid and long distance communication extend this capability still further.

Political and economic forms and systems are social tools that extend man's capabilities for living and cooperating in groups of progressively increasing size. Religious, philosophical and scientific interpretations are tools that extend man's capabilities for understanding, rationalizing, and adjusting to the nature of the environment in which he finds himself, and the universe which his increasing knowledge reveals to him.

Anthropologists generally agree that the development of the ability to make tools marks the beginning of man as a species, and constitutes the major difference that sets him apart from his pre-human ancestors. Human evolution has been characterized by a further and continual elaboration of this tool-making characteristic. Every tool has been created to meet a challenge posed by the environment. Man has adjusted to the challenges of his environment through evolving tools, rather than by specializing parts of his body, as other animals have done, such as horses, birds, moles, and seals.

It is this ability to make and evolve tools which serve as extensions of his body and its capabilities, to solve his problems by shaping and utilizing things outside himself, that makes man MAN, and something different from and more than any other animal.

Extending Man's Body With Tools

Introduction:

A laboratory experience is any situation where there is a problem, and a tentative answer is being looked for. Usually this involves a great deal of doing, and thinking in connection with the doing. Here we have a different kind of laboratory experience: one that involves a great deal of thinking, and some doing in connection with the thinking.

Man has many capabilities through the use of parts of his body. Anything which enables him to use these parts more effectively or to accomplish a wider range of activities, extends the capabilities of his body and constitutes a tool.

Materials and Equipment:

Watch

Two tin cans and a long string

Sheet of typing paper

Foot rule

Procedure:

Mentally compare yourself or your neighbor with a four-footed animal such as a cat or dog. Now try to think of something that you can do that the cat or dog cannot do at all, not even to a small degree. Can you think of any such thing? Be careful, because you may fall into the error of thinking that the cat or dog cannot do something that you can, simply because it does not do it in the way you do. For example, the cat or dog cannot talk, but it can communicate to a limited degree, and talking is simply your way of communicating. What things can you do to a greater degree than the four-footed animal? What things to a lesser degree? What things about the same?

Do you think the cat or dog can hear better than you can. What evidence do you have that makes you think as you do? How far from your ear can you hear a watch tick? Is the distance the same for both of your ears? Now make a paper funnel of a sheet of typing paper. Place it in your ear and try again. Can you hear to a greater distance than before? Has the paper funnel extended your hearing? Express the degree of improvement as a percent.

See if you can similarly extend your speaking by using a can-and-string telephone. Punch a small hole in the bottom of each of two tin cans, and connect them with a long string attached through the holes. Speak into one can and have a partner listen at the opening of the other. To what distance is this device effective? Extend it as far as you can. Express the increase in the distance over which your normal speaking voice can be heard as a percent.

Some four-footed animals have claws, and you do not, although your finger and toe nails correspond to claws. What items would you add to the list of materials and equipment that would enable you to scratch like a cat? To dig like a dog? Would these serve to extend your hands in a manner comparable to that by which the paper funnel and can-and-string telephone extended your hearing and speaking? How is the extension similar? How different?

Move a small object with the end of a foot rule held in your hand. How is this extending? How is throwing a stone extending? Think of other things that you can do that are comparable. What devices do you use? Is driving a car extending? What is being extended?

Are all tools extensions of man's body? See if you can think of any tools that are not. Can a four-footed animal use tools? Do any animals other than man use tools? Do we have a real difference here between man and other animals? How is tool-using related to man's walking on his hind legs? How is it related to his large brain? What do we mean when we say that man has a problem-solving brain? What part do tools play in man's problem-solving?

Try to write a definition of man as distinguished from other animals, using the ideas included in this laboratory experience.

Extensions of Man's Body: Simple Machines

Introduction:

The complex machines on which civilization depends are essentially combinations of simple machines powered by outside sources of energy. There are only a few of these simple machines. They were discovered by primitive man, very early in the course of his development of civilization. Most of them were in use at the time when he began to build his earliest cities, and they have continued to be used with increasing elaboration and complexity until the present. The following laboratory experiences are designed to help you understand the physical relationships involved in these simple machines. These relationships make it possible for them to serve as extensions of man's body and its capabilities.

Materials and Equipment:

Yardstick (new, clean, and as free of knots and grain as possible)

Ring stand with crossbar or other means for suspending the yardstick and supporting an inclined plane.

Triangular file

String

Set of weights up to 500 grams, or with combinations possible up to this amount

Spring type kitchen scales (two or more)

Laboratory balance

Protractor

Toy truck or other small wheeled toy, weighing at least 200 grams.

Board, 2" x 4", 8 feet long

Board, 1" x 6", 3 feet long, with a small pulley affixed at one end. The wheel of this pulley should be placed far enough beyond the end of the board so that when the board stands at a 45 degree angle a string can pass around the wheel and descend perpendicularly without touching the end of the board. (If a small metal pulley is not available, a pulley can be constructed by mounting a wooden spool on a spindle attached to a wooden frame).

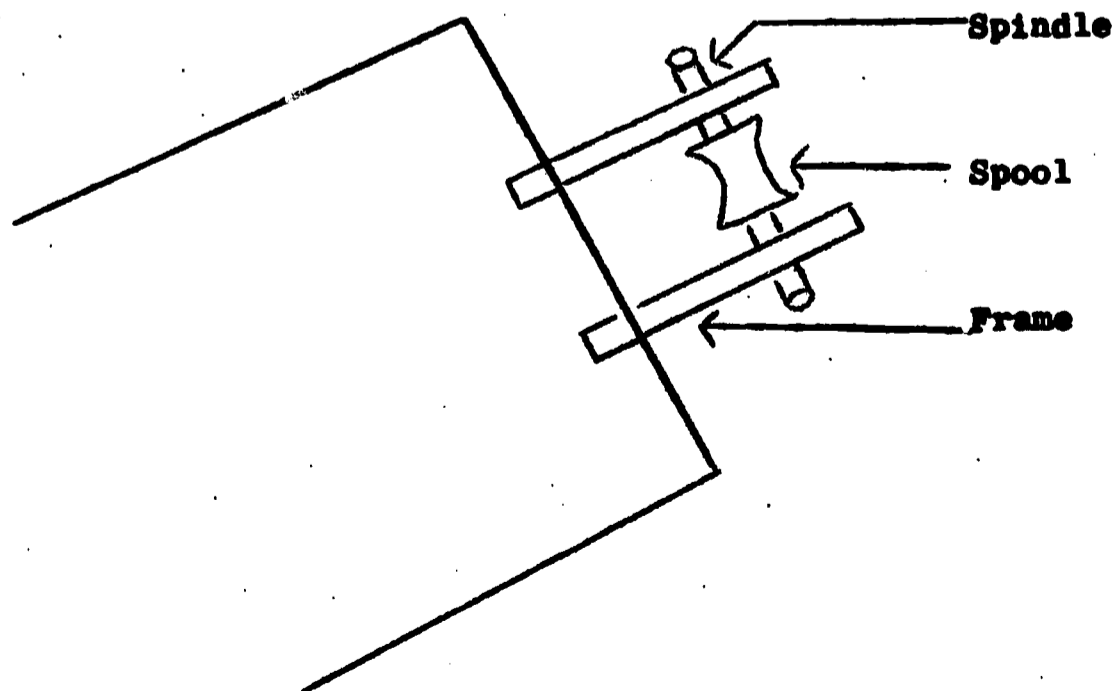

A. The LeverProcedure:

(Note: Steps 1 and 2 may be omitted if the yardstick which was prepared for the laboratory experience entitled Measurement as an Expression of Relationship: A Simple Balance used here.)

1. With the triangular file, make a notch across the top of a yardstick at its exact midpoint. The notch should be deep enough to hold the string which will be tied around the stick. Using a piece of string about six inches long, tie it around the stick with the knot lying in the notch. Leave the two ends of the string of equal length. Tie the ends together, and hang the stick from a support. Does it balance? Or is one end higher than the other? If so, why?
2. With the file, make shallow notches across the top of the stick at each quarter-inch mark, from the midpoint to the end of each side. Be careful to make the notches straight across the top of the stick, as uniform in depth as possible, and each one exactly on the quarter-inch mark. Suspend the stick again. Is it as well balanced as before? If not, what do you think has happened?
3. By means of a string, suspend a 100 gram weight from a point near one end of the stick. Then find the point at which a 200 gram weight, similarly suspended, must be hung on the other end so that the stick will rest in an exactly horizontal position.
4. The point at which the stick is suspended is called the fulcrum. The result of multiplying the weight on each side by its distance from the fulcrum gives a figure which is called the moment of the force exerted by the weight. Find the moment of the force exerted by each of the two weights. What relationship exists between the two moments? Why?
5. Substitute a spring type kitchen scale for the 100 gram weight, and a 500 gram weight for the 200 gram weight. Hold the scale in your hand and rest your elbow on the table in order to get a more accurate reading. Try various positions for both the weight and the scale. From the scale, determine the amount of force necessary to balance the 500 gram weight in each position. Replicate the experience with two or more spring type scales or compare your results with those of other groups. What is the margin of error that is involved? Keep this margin of error in mind when you are working with spring type scales in connection with other experiences.

Your scale will probably be marked in ounces instead of grams. Look up the number of grams equivalent to an ounce. Use the gram equivalent for the number of ounces indicated. Calculate the moments in the case of all positions tested. Does the relationship which you found in step 4 hold consistently? Is there a margin of error?
6. Substitute an object of unknown weight for the 500 gram weight used in step 5. Assuming that the relationship which you have found is consistent, determine amount of force exerted by this object. Weigh the object on the laboratory balance. Is the weight consistent with the force?

7. Using a fulcrum resting on the floor, and a 2" x 4" board 8 feet long as a lever, raise objects of various weights. Determine the relationships involved in each case.

The lever is a simple machine. A small amount of force, exerted through a greater distance, is able to accomplish work in the form of moving a weight which exerts a greater amount of force through a lesser distance. A man, exerting only the force of his own body, using a lever, can move a much greater weight than he himself represents. An ancient Greek mathematician said that if he had a lever of sufficient length, and a fulcrum on which to rest it, he could move the earth. A lever, therefore, may be thought of as an extension of man's body and its capabilities.

A lever consists of three parts. One is the place where the force (effort) is applied. The second is the fulcrum, the point on which the lever turns. The third is the place where the work is done (resistance). In a lever such as you have been using, the fulcrum lies between the effort and the resistance. This is called a lever of the first class. In a lever of the second class, the resistance is located between the effort and the fulcrum. In a lever of the third class, the effort is applied between the resistance and the fulcrum.

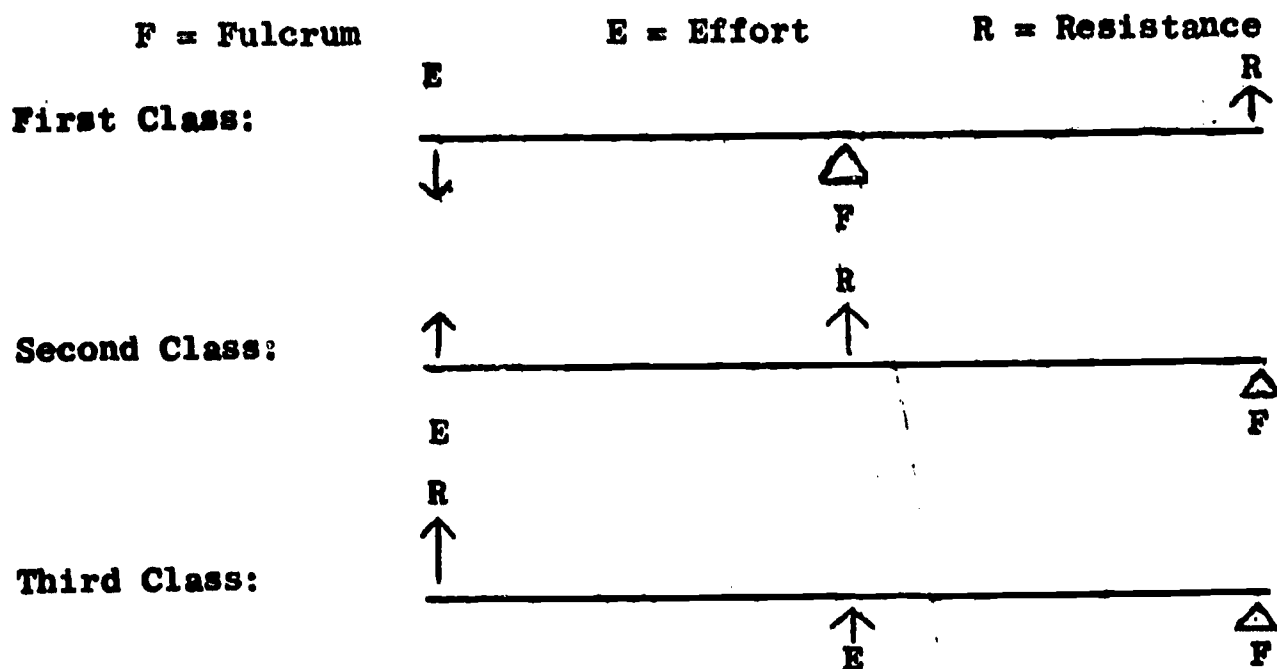

Further Investigations:

Set up examples of levers of the second and third classes, and see if the relationships which you have found for levers of the first class hold for these also. Can you think of common examples of tools that utilize levers of each of the three classes?

B. The Inclined Plane

Procedure:

1. Set up an inclined plane at a 45 degree angle, using a 1" x 6" board, 3 feet long, with a small pulley attached at one end. Use a ringstand with a crossbar or other means to support the raised end of the inclined plane.

2. Thread a string over the pulley. Allow both ends of the string to hang perpendicularly. Attach a toy truck or other small wheeled toy weighing at least 200 grams, to one end of the string, and a spring scale to the other end. Holding the scale in your hand, determine the amount of force necessary to lift the toy, as indicated by the reading on the scale. If the scale is marked in ounces instead of grams, calculate the gram equivalent of the number of ounces indicated.
3. Weigh the toy on a laboratory balance. Does the weight of the toy correspond to the force which it exerts over the pulley.
4. Now detach the toy from the string, and re-attach it in such a way that the string over the pulley will draw it up the inclined plane.
5. Determine the amount of force necessary to draw the toy up the inclined plane, set at a 45 degree angle. How does the force exerted in this case compare with the force exerted when the toy was lifted perpendicularly? What is the relationship? Multiply the length of the inclined plane by the amount of force necessary to draw the toy along it. Then multiply the height of the uppermost point of the inclined plane by the amount of force necessary to lift the toy perpendicularly. What is the relationship between the figures obtained in the two cases?
6. Now adjust the inclined plane to an angle of 30 degrees. Determine the amount of force necessary to draw the toy up this less steep inclined plane. Compare the force exerted in this case to the force exerted in the case of the 45 degree inclined plane and the perpendicular pull. What is the relationship? Again multiply the length of the inclined plane by the amount of force necessary to draw the toy along it, and the height of the uppermost point of the inclined plane by the amount of force necessary to lift the toy perpendicularly. What is the relationship between the figures obtained? Is the relationship the same as that found in the case of the 45 degree inclined plane? Why?
7. Adjust the inclined plane to an angle of 15 degrees and determine the amount of force exerted in drawing the toy along it. Compare to the 30 degree inclined plane, the 45 degree inclined plane and the perpendicular pull. What is the relationship? Is it constant? Why? Again multiply the length of the inclined plane by the amount of force necessary to draw the toy along it, and the height of the uppermost point by the amount of force necessary to lift the toy perpendicularly. What is the relationship between the figures obtained? Compare to the 30 degree inclined plane and the 45 degree inclined plane. What general conclusion can you draw?

In the case of the lever, you found that a small amount of force exerted through a greater distance is able to accomplish work in the form of moving a weight which exerts a greater amount of force through a lesser distance. Can you see a similar relationship here? Can you express what happens in both cases in the same general terms? Try to do so. What is meant by mechanical advantage? How may an inclined plane be thought of as an extension of man's body and its capabilities?

Further Considerations:

How are the wedge and the screw related to the inclined plane? Describe them in terms of the inclined plane. What common tools utilize the principle of the wedge? Of the screw? List as many examples as you can in the case of each.

C. The Wheel

Procedure:

1. Turn the wheeled toy which you have used upside down, so that it drags rather than rolls, or utilize an object of identical weight and similar size, but without wheels.
2. Determine the amount of force, as measured by the spring scale, exerted in lifting the wheel-less toy or similar object perpendicularly, with the string operating over the pulley at the top of the inclined plane. Compare this with the weight of the same object, weighed on the laboratory balance. Work out the gram equivalent of the reading on the spring scale as in previous experiences.
3. Now, using the spring scale, determine the amount of force in grams necessary to drag the wheel-less toy or similar object up the inclined plane at a 45 degree angle. At a 30 degree angle. At a 15 degree angle. Compare the amount of force exerted in each case with that exerted in moving the wheeled toy in a comparable situation, obtained in your earlier experiences with the inclined plane. What do you think accounts for the differences in the amount of force exerted in moving the wheeled and wheel-less objects of the same weight up the inclined plane? Was there a difference in the amount of force exerted in lifting the wheeled and wheel-less objects perpendicularly? Considering this, what do you think was the function of the wheels?
4. What is friction? What are some of the means that have been devised to reduce it? Can it be eliminated altogether? Does it operate in connection with the movement of wind and water? With the rotation of the earth? With other kinds of motion in the universe?

Further Considerations:

Is the wheel, considered alone, a simple machine? What about the wheel when it is attached to an axle? What about combinations of wheels? Gears? Pulleys? What about a fixed pulley such as you have been using at the top of your inclined plane? It operates on an axle, but is not attached to it. What about movable pulleys, or combinations of fixed and movable pulleys?

Can you express what happens in the operation of gears and pulleys in the same general terms that you used to express what happens in the case of levers and inclined planes? Try to do so. How may gears and pulleys be thought of as extensions of man's body and its capabilities?

Is the wheel, considered alone, an extension of man's body and its capabilities? Is it a tool? What civilizations developed to a relatively advanced state without utilizing the wheel?

General Applications:

Bring in toys, household tools, and other devices that make use of the principles involved in these experiences. Note that some of these devices are based on simple machines, while others constitute combinations of simple machines. Cite examples of simple machines and combinations of them from work, sports, and life experiences in general. What about movements of the human body and the bodies of other vertebrates? What about the movements of insects? What about those of clams?

Extensions of Man's Body:

Complex Machines and Utilization of Outside Energy

Introduction:

Man has learned to supplement the energy which he is able to utilize directly in connection with his own body, with additional supplies of energy from outside sources. This outside energy has made possible the development and use of the complex machines that play such a major part in modern civilization, multiplying its productivity, but at the same time multiplying its problems, and placing constantly increasing demands on man to adjust to it. These machines are so much a part of our world that we tend to take them for granted, without realizing that they, as well as the simpler devices which preceded them in our cultural development, constitute extensions of our bodies and their capabilities.

Man is a tool maker, and the point in his development at which he began to make tools is generally considered to be the point at which he became man. Now, because of the machines that he has made, we recognize that the environment which will shape his future is becoming increasingly one of his own creation.

In this laboratory experience we will examine the relationship of man's complex machines (1) to the capabilities of his body, (2) to simple devices which have extended these capabilities, and (3) to outside sources of energy which make it possible for complex machines to extend these capabilities still further.

Equipment and Materials:

A square of stiff paper 5" x 5"

Ruler

Scissors

Pin

Lead pencil with rubber

Glass bead or small button

Cardboard fan

Electric fan

Some familiarity with a bicycle and an automobile

Can-and-string telephone

Some familiarity with telephone, radio and television

Procedure:

1. Construct a paper pinwheel:

Use a piece of stiff paper, 5" square.

Draw two lines connecting opposite corners. If these are drawn carefully, the lines will cross in the exact center of the square.

On each of the four lines going out from the center, make a dot $\frac{1}{2}$ " from the center.

Cut in from the corners of the square along each of the four lines until you reach the dots.

Now bend in to the center each of the corners marked "A" in the diagram.

Run a pin through the four corners and through the center of the square.

Mount the pinwheel by inserting the pin into the rubber end of a lead pencil. Place a glass bead or small button between the pinwheel and the rubber to reduce friction.

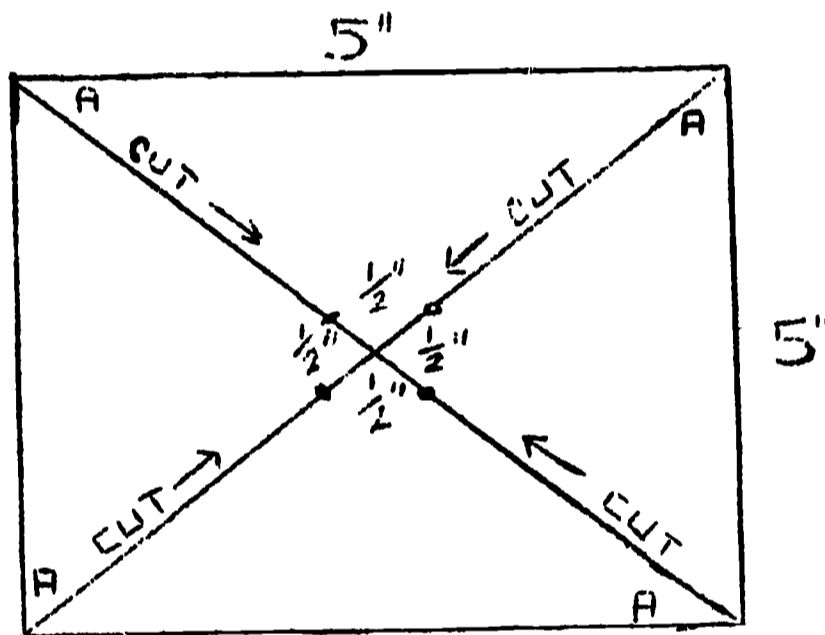

2. Blow on the paper pinwheel. See how rapidly you can make it run by blowing on it. What proportion of the time are you able to keep it in motion? Try cooperating with someone else. Can you keep it in motion, or make it move faster, by working together?
3. Now use a stiff piece of cardboard as a fan to create currents of air. Are you able to make the pinwheel move faster or keep it in motion more nearly constantly by using the cardboard fan as a simple tool? Try it with two people using cardboard fans. Can you work more efficiently, either alone or as a team, using a simple tool than by using only your breath? What are some of the lessons that primitive man learned about using tools, and about cooperation? To what simple machine is the cardboard fan related?
4. Hold your pinwheel in front of an electric fan. Compare the rate and constancy of its turning with the results obtained by blowing on it, and by hand-fanning it. Can you arrive at any quantitative statement (based on a rough estimate) of the difference in behavior of the pinwheel under the three comparable conditions? Try to do so.

You have now recapitulated the development of human effort (using a simple example to illustrate a much broader and more complex process) covering a period of perhaps 20,000 years. This has involved the following stages:

- a. Use of man's body and its capabilities
- b. Use of a simple hand tool
- c. Use of a complex mechanism, dependent on outside energy.

See how far you can trace the source of the electrical energy that was used to turn your electric fan. What are some of the methods of producing electrical energy? Find out all you can about that happens when energy changes state. What is meant by conservation of energy? Does all of the energy from the original source ever reach the electrically-operated device (e.g. motor, light bulb, heating unit)? What happens to it along the way? Why? How efficient is an electric motor? An electric light bulb? (That is, how much of the energy that actually reaches the device is turned into motion or light?) What happens to the rest of the energy?

5. Now go through a similar series of steps in your thinking, following a different line of mechanical development, using successively:
 - a. Locomotion by walking
 - b. Riding a bicycle
 - c. Driving an automobile

Note that in the case of the bicycle and the automobile you are dealing with complex machines which are combinations of simple machines. What simple machines are involved? In the case of the bicycle, however, human muscle power is used as an energy source, the same as in walking. In the case of the automobile, an outside energy source is substituted. Compare the degree of increase in accomplishment in this series with that which you have observed in the simple case of the pinwheel and the air currents. What is meant by "horsepower" in the case of an automobile or other type of engine.

How much of the potential energy of the gasoline is actually converted into motion by the automobile? What happens to the rest of it? Why does a small foreign car or a light American compact deliver more miles per gallon than a heavier car? What about accessories, such as power steering, power windows, power brakes and automatic transmission? Why?

6. See how far away you can hear a watch tick. Now see how far away you can make yourself heard, speaking in a normal tone of voice. (The use of the watch along with your voice gives you an objective standard of comparison. Why do you need this? See below)
7. If you have done the laboratory experience called Extending Man's Body With Tools, use the can-and-string telephone that you made there. If not, make one by punching a small hole in the bottom of each of two tin cans, and connecting the two cans with a long string attached through the holes. See how far you can hear a watch tick through the can-and-string telephone. See how far you can make yourself heard, speaking normally. Try to arrive at a quantitative statement, comparing the distances at which the watch ticking and the normal speaking can be heard without and with the aid of the can-and-string telephone.

8. Now think of the vastly greater distances over which communication by voice is possible, using devices which depend on electrical energy in various forms: telephone, radio, television. When you do so, you have followed a third series of mechanical devices, again recapitulating the development of human effort through the same three stages: (a) use of man's body and its capabilities, (b) use of a simple tool, (c) use of complex mechanisms powered by outside energy. Can you think of other such series?

Find out all you can about how the human voice is carried in the case of telephone and radio, and how both sound and picture are carried in the case of television. Note that a general principle is operative in all cases: transference of pattern. The sound wave pattern of the human voice (or other sound) is transferred to an electric current, radio waves, light waves or other medium in the form of a corresponding pattern. In some cases several successive transfers are made, involving a series of different media. Ultimately the pattern, superimposed on an appropriate medium, is sent out over a wire or broadcast, and is received and a sound wave pattern similar to the original is recreated by the receiver. Without having to know exactly how all of this is done, see how much you can find out about it. How "true to life" is the recreated sound?

See if you can find a similar principle operating in the case of the recording and reproducing of sound in the making and playing of sound tapes and records. What is meant by "Hi-fi"? Why is it called that? What about loud speaker systems? How are they similar?

In the case of television the picture is broken up into a series of horizontal lines ("scanned"). These lines, when "strung out" in succession, constitute a continuous series of points having varying intensities of light and darkness (or color differences). Thus they form a pattern which can be transferred, broadcast, received and put back together into the form of a picture. See how much you can find out about the process. How are picture and sound coordinated? How is television related to motion pictures? To ordinary photography? See if you can carry the idea of transference of pattern over to these.

Further Considerations.

Think of other applications of outside energy that make possible man's adjustment to the modern world which he has created. What about space travel? What forms of energy are involved in it? What forms of energy have been suggested for use in space travel over greater distances in the future?

What about new energy sources to replace those that are being used up? What about fission energy of radioactive materials? What uses are being made of it now and what additional uses are in sight? What about fusion energy? What are the prospects for its development and control? What would development of a successful method of utilizing it do to the world's energy prospects?

Extensions of Man's Body: How They Have Evolved

Introduction:

With his development of the upright posture man began an entirely new kind of evolution. Because his upright position left his hands free for grasping, he began to use tools. He adjusted to his environment and attempted to solve the problems that it presented by evolving tools, rather than by changing his body form. This has constituted a kind of substitute evolution, or evolution by proxy.

Thus, instead of changing himself into a highly specialized running animal like the horse, he invented and evolved machines to do his rapid traveling (locomotive, automobile, bicycle and motorcycle). Similarly, instead of evolving, like the seal or walrus, into a highly specialized swimming animal, he invented and evolved various kinds of boats and ships to do most of his swimming. He evolved weapons instead of specializing his teeth and claws for defending himself, fighting and killing prey. He evolved airplanes to do his flying, bulldozers to do his digging, and even complex machines to do some of his remembering, calculating and thinking. The movement toward automation is a development of our time. Self-repairing machines may well be a development of the future.

We have evolved a bewildering variety of tools for dealing with the problems presented by our environment. Here, of course, we are using the word "tool" in a much broader sense than usual. A tool is anything which is useful in solving a problem. The evolution of man's physical tools may well have begun when he first picked up a club or a stone to ward off an attack by another animal or an angry neighbor. He was using a tool to solve a problem presented by his living environment. This might well involve his survival.

There are many other examples of tools used to solve environmental problems. If it is raining you wear a rain coat to solve a problem of environmental adjustment. Your ancestors did not evolve a coating of coarse hairs to shed the rain as some other animals did. They invented clothing (including raincoats) instead. You wish to get an idea across to another person. Getting it across constitutes a problem. You use written or spoken language as a tool to deal with this problem, possibly devising new word combinations or even inventing new words to adapt the tool to the need.

Social, political and economic systems are tools which we have evolved for dealing with problems of commodities, media of exchange, distribution of goods, and standards of living. Money and commodities themselves are tools for meeting human needs. Ideas are tools for solving problems in human thinking. These ideas affect our actions.

The words that you have just read have been used in a particular combination as tools for expressing the idea that man has extended his physical body and its capabilities in many ways to adjust to his environment. The bodies of other animals have undergone structural changes in becoming specialized to deal with a particular kind of life. Later, because of their specialization, they have found themselves unable to live at all except in a special habitat: the sea, the freshwater of ponds and lakes, open plains, forests, the tropics, the arctic.

Man's body, on the other hand, has remained relatively unspecialized. By evolving and using tools, in the broad sense that we have used the word, he has been able to adjust even better to the same problems to which other animals have adjusted. He has also adjusted to many other problems. It is because of this that man has become dominant over the whole earth, and soon, possibly, over other worlds also.

Resources for the Problem

No special equipment or materials are necessary for this laboratory experience. A number of different kinds of resources, however, will prove useful. These include back files of magazines, especially the National Geographic Magazine. Nearly any library will have some of these. Sometimes complete or nearly complete files, going back fifty years or so, have been kept. Old newspapers, books on history, any books which describe or picture the ways in which people lived, and the things that they used before our time, will be helpful. We are living in a period of rapid change, and it will surprise you how shortly before our time conditions differed greatly from the present.

If a museum is available near where you are, it will furnish an excellent resource for study. Antique shops are full of things that people formerly used: old furniture, old dishes, old utensils, old tools, sometimes old books. Many people collect these things. Your parents or your friends' parents may have some of them. Old snapshots and collections of family portraits are useful in some cases. Conversation with older people, your grandparents or others their age, is a good resource.

A part of your problem is to locate appropriate material. It is necessary to learn how to look for it. This is a good opportunity to learn about the community where you live, and the things and people in it. You should make the most of this opportunity. Any community has a great deal of material which will be useful for this study. A rural community is in some ways more advantageous than an urban community, and vice versa. The resources available in one are different from those in the other. No two communities, even of the same type, are alike in this respect. You will find your study very interesting.

Procedure:

This study may be carried on in the form of individual, out-of-class projects, or by field trips which may be arranged to suitable places. Probably, in most cases, a combination of these two approaches will prove best. It may be desirable for different students or groups to work on different aspects of the study, and then bring their results together for the benefit of the class.

Evolution of the Automobile

The automobile began in the 1890's with a combination of some features taken from the bicycle and some from the carriage, together with a motor for propulsion. The motor was originally placed beneath the car, but was very quickly moved to the front, possibly because this was where the horse had been. There have been various experiments with rear-end drives.

These have generally proven more successful in Europe than America. The German Volkswagen is a notable example. Can you think of any others? The automobile has steadily evolved during the past two-thirds of a century toward a form that is uniquely its own, yet which still shows some evidence of its origin.

The National Geographic Magazine began publication in 1889. It has carried advertisements which pictured automobiles since the early years of this century. These advertisements constitute an excellent source for tracing the evolution of the automobile. Study these or any other available sources. What changes can you observe in the external appearance of the automobile? Can you identify any trends? When did they first appear? What kinds of cars were sold at the time of World War I that are no longer on the market? Were the present kinds available then? What new ones have appeared? Were these really new or were they variant forms of older ones? How does the number of companies making cars compare with the number at the time of World War I? What has happened? Why?

Of course the external appearance of cars tells little or nothing about internal changes. Talk with an older person who has driven cars for most of his life, and ask him to recall what some of these internal changes have been. How about number of cylinders? What about gear shift? What about method of starting the motor? Any others? What about accessories? Is it possible to discover any trends? Try to account for these changes in terms of the environment in which the automobile has operated in the past half century or longer (roads, growth of population, growth of cities, general improvement of standard of living). What about over-all size of cars? Compare automobiles used in America and in Europe in this regard, and try to account for any differences that you find. What about cost of gasoline? Has the quality of gasoline improved? Have cars become more efficient in their use of gasoline? What about tires? What about driving speed? What about cost of cars?

How has increased use of the automobile affected the geography of our cities? What about the future? What problems must we face in connection with increased use of the automobile? See if you can find out what is the present thinking of the automobile manufacturers with regard to new developments in motor and body design.

Try to account for the changes which have occurred in the evolution of the automobile in terms of natural selection. This is survival of that which works, and elimination of that which works less well. What are the selective factors that have operated in the evolution of the automobile?

Evolution of the Airplane

The airplane began through experimentation with man-lifting kites and studies of the flight of birds. The first airplanes were essentially man-lifting kites with motors for propulsion. How does an airplane stay in the air? What is Bernoulli's Principle? Can you think of any common examples of its operation that you have observed?

With the attainment of greater speeds, the airplane has evolved steadily in the direction of becoming a projectile, manned or unmanned. How is this evident in its external appearance? What have changes in the kinds of

motors used for propulsion had to do with this? What kinds of motors are now available for propulsion? The intercontinental ballistics missile and the development of space ships constitute the ultimate in this line of development. What means of propulsion and structural designs are possible for use outside the earth's atmosphere in interplanetary space? Why?

Following the same general lines of investigation as have been indicated for the evolution of the automobile, study the evolution of the airplane. Here old magazines will give you less help. On the other hand, more material on present and possible future developments will be available in current and recent newspapers and magazines. Also you will find more material in books and in textbooks. Again talk with older people who remember some of the stages in the evolution of the airplane.

How have airports evolved along with airplanes? What about spaceports? What effect has the military use of aircraft had on the evolution of the airplane? What about the increase in air travel by civilians? Has the use of the automobile also entered into this picture? What have been the selective factors that entered into the evolution of the airplane? Have they been the same as those that have operated in the case of the automobile? If so, why? If not, why?

Evolution of Language

New words are constantly appearing. Sometimes they survive, but more often they do not. In some cases, however, whole new vocabularies replace old ones. When man's activities change, and the things that he does give way to others, new words become necessary, and old words become obsolete. This happened when the automobile, truck and tractor replaced horses and horse-drawn equipment. The very words "truck" and "tractor" themselves were new or acquired new meanings. A "truck" formerly meant a small hand-pushed carrier for luggage. The word "tractor" is entirely new. What is the derivation of the word "automobile?" A generation ago radio, and more recently television, brought new words into the language. Language evolution is, in general, related to people's need for expression in situations of actual living. When the situations and relationships change, language changes with them. At some periods and in some places, the change is rapid. At other times and in other places it occurs slowly or not at all. It is in this way, however, that the languages that we have in the world today have developed and differentiated from one another. Anthropologists estimate that it takes about 20,000 years for two languages which have a common ancestor to become completely separate.

There are books on the development of language differences which are non-technical and interesting. Look for some of these in your local library. Occasional articles in newspapers can be found dealing with these topics. Your best resource, however, at least to begin your study, is your own experience. Observe differences in speech among people from different parts of the country, between rural people and city people, between older people and younger people. What differences can you discover? What is dialect? What dialects can you detect? Dialects differ in different sections of the country, sometimes even in different cities. Sometimes such differences can be detected on television, watch for them.

Talk to your parents and other older people and with their help try to identify words like "radio", "television", "nylon", "paperback" that

have come into existence in recent memory. You can easily compile long lists of these. Some you will be able to think of from your own experience. Others, like "refrigerator" are more than a generation old. Try to find out what brought them into existence. Some are manufactured words (like "rayon", "penicillin"); some are even commercial brand names (like "scotch-tape," "kleenex", "band-aid") that have come to mean a kind of product, rather than simply the brand of that product made by a particular manufacturer. Other manufacturers of the same product may not like this. What effect do you think it might have on sales?

Identify slang words and terms current among your friends. These change rapidly, often in a single year. Few of them survive. Ask your parents about slang terms that were current when they were young. Have any of these survived? Do your parents still use any of them? Do you? Have your parents or teachers taken up the use of any of your slang terms? To a large extent slang belongs to the language of young people.

When the same language is spoken in widely separated countries, it may evolve differently, using different words for the same new development when it arises. In England and the United States this has happened. What words are used in England that correspond to our "radio", "truck", "gasoline", "hood" (of a car), "trailer", "elevator"? Can you find others that differ?

See if you can find a list of words pertaining to horses and horse-drawn vehicles, which formerly were in general use, but now are limited to hobby groups and others who still use horses. How might you go about investigating this?

Evolution of Clothing

The evolution of clothing has shown long-time trends related to availability of materials and the activities in which people engage. Thus, the introduction of cotton into the Mediterranean world in ancient times, and the availability of silk following the development of trade with the Far East at the close of medieval times, made possible changes in certain types of clothing. The development of various kinds of synthetic fabrics in our own time has produced even wider effects.

The replacement of natural dyes by synthetic ones, which followed the discovery of the first aniline dye by the English chemist Perkin in 1858, has resulted in the use of a far greater variety of colors and shades, and the availability of brighter and more permanent colors. How is this comparable to what is happening now in the case of fabrics? Can you think of other similar examples?

One field of cultural evolution reacts upon another. There are complex interrelationships among different aspects of people's adjustments to the problems of their environment. In ancient times in the Mediterranean lands, workers went naked or nearly so, while women and the non-working classes of men wore long, flowing costumes. With the spread of Christianity and acceptance of its concepts of modesty, working people came to wear clothing, more or less close-fitting, as befitted their active life. Women and non-workers continued to wear clothing of long, flowing type. What happened in Polynesia with regard to clothing when missionaries introduced Christianity? What about clothing among primitive tribes at the present time? To what extent do men and women all over the civilized world wear

the same kinds of clothing now? Why? How does this compare with conditions fifty years ago? Why?

In western countries, during medieval times, men of the working classes came generally to wear trousers, but the men of the non-working classes, prior to the political revolutions of the late 1700's, wore knee breeches with elaborate coats, collars, stockings and shoes. Following the French and American Revolutions, the long trousers of the working classes were adopted by all men. Why do you think this happened? Study pictures in books on the history of Europe and America, and see if you can determine just when this change occurred.

Women continued to wear long, flowing clothing generally until World War I. What changes took place in women's clothing in the decade following World War I? Why do you think these changes occurred? When did the custom of women wearing slacks develop? Why?

What has happened to the heavy winter underwear that both men and women used to wear? Why? What has happened in the case of outdoor clothing for winter? Why? How have bathing costumes for both men and women evolved during the past seventy-five years? Why?

Study clothing evolution during the past hundred years. What specific changes have occurred in women's clothing? In men's? Which has shown the more rapid changes? Why do you think this is so? Long-term evolution should not be confused with fashion change, but the same trend may reappear in succeeding fashion cycles. What influence do you think fashion has? Temporary? Permanent? Do you think that long dresses for women for day-time wear will ever come back? For an extended period of time? Why?

You will find family portraits and other pictures of people long ago the best available source for a study of clothing evolution. Beginning about the time of World War I, with the invention of the small, portable camera, the making of "snapshots" became common. What about the word "kcdak"? Examine snapshot collections in your own family and those of your friends. These may include as many as three generations. Pictures of people in advertisements in old magazines are a good source if they are available. Talk to your parents, grandparents and other older people. Most museums contain old costumes. Note the colors of these as well as the costumes themselves. How are they different? Is this due entirely to their age?

Further Investigations:

In any kind of evolution there is the phenomenon of old, primitive or ancestral types persisting in out-of-the-way places which are marginal or isolated. In these places the environmental conditions have not changed, competition is not great, and the stream of development has passed them by. Students of biological evolution call these primitive types "archaic", and the places in which they survive "relict" areas. Such places are found in deep lakes of ancient origin, mountainous areas, the depths of tropical swamp forests, desert areas, islands in the sea, the extreme edges of continents, and isolated peninsulas off larger land masses. The archaic species of plants and animals found in such places are the "living fossils" of popular journalism. What are some examples?

In the area of proxy evolution such "living fossils" can be discovered in any of the classes of tools that man uses. They are found in any conser-

vative situation where, for one reason or another, the stream of living has passed them by. The necessity for change to meet new situations and problems has not been sufficient to cause them to be abandoned. They are more likely to survive in rural areas than in cities, in hilly or mountainous areas than in plains areas, and in poor soil areas than in good soil areas.

"Language islands" and conservative religious groups preserve antiquated forms of dress, language and other cultural devices. Ceremonies and traditional festivals, such as are carried on in some European communities and Indian tribes, fall into the category of relict areas which preserve antiquated forms, especially of dress. Can you think of any others? What about weddings? Can you think of any cases where these antiquated customs have been artificially perpetuated or revived as tourist attractions?

Kerosene lamps and horse-and-buggy transportation have been retained longest in hilly or mountainous, poor-soil areas. Older people are the ones most likely to cling to "old-fashioned" things and forms of speech and dress. Why? Horse-drawn farm implements have survived similarly. Old models of automobiles in everyday use disappear last in poor, rural, hill districts.

If a museum is available, look in it for old methods of lighting, old forms of transportation, old farm implements, old types of dishes, glassware, furniture, hand tools, and other old things. The Henry Ford Museum and Greenfield Village at Dearborn, Michigan, has an excellent collection of these things. The Museum of Science and Industry in Chicago has some of them. Almost any historical museum will have at least a few of them.

Antique shops are filled with some kinds of old things. Ask your parents if they know of people who have private collections of some of them. Try to find and study some of these things. Can you identify any trends in their evolution? What kinds of forces and influences do you think shaped their development? See if you can discover or figure out answers to some of these questions.

The isolated, mountainous, poor-soil districts of the South preserve many of the language forms of Middle English. This is the English language of the time of Queen Elizabeth I, the King James version of the Bible, and Shakespeare. Many of the medieval ballads which have long since disappeared in England have been found in the southern mountains, which began to be settled when Middle English was still being spoken, and the ballads were still being sung in the home country. Have you ever heard any of these songs? Listen to some of them in a record collection. If you know any people who come from these areas, listen for differences in their speech. What are some of the differences?

Ancient language forms also persist in the rituals of churches. Since religions tend to be conservative, these are comparable to the survival of other archaic forms. Such church languages are called ecclesiastical languages. The use of Latin as an ecclesiastical language in the Roman Catholic church is well known. Nearly all religions show some phenomena of this kind. What other specific examples can you discover?

Religions may also preserve old clothing types. The clothing worn by Roman Catholic monks and nuns falls in this category. What other examples can you think of? Generally both language forms and clothing forms tend to preserve the types that were in use at the time the religion was founded or the particular custom originated. What about Salvation Army uniforms? To what military uniforms are they related? Why?

How is the evolution of man's machines, language, clothing, other cultural forms and ideas--tools in the broad sense for dealing with problems posed by his environment--comparable to the evolution of plants and animals during the earth's long history? In what ways is it similar? In what ways different? What examples of this kind of evolution can you think of other than the ones suggested here? To what extent are all forms of evolution related?

XVI

Sample Tests

These are teacher-constructed tests, based on questions asked by students following completion of laboratory experiences looking toward specific Ideas. In the case of each test the laboratory experience on which it was based is indicated. The Ideas were taught, the laboratory experiences were carried out, and the tests were constructed in accordance with the practices recommended in Suggested Procedure for a Teacher Wishing to Use MSCC-JHSP Materials.

These tests are samples only. They should not be used outside the setting for which they were constructed. It is hoped that teachers will construct their own tests, following the practices recommended in Suggested Procedure.

Test to Determine Your Understanding of Measurement as an Expression of Relationship

(Based on laboratory experiences: (1) "A Study in Measurement, (2) "A Simple Balance," and (3) "Volume, Weight, Pressure, and Physical State")

Basic Concept: The act of measuring things has always been a very important human activity. Since the earliest times the measurements that people have made have always consisted of an expression of the relationship of one thing to another in terms of quantity. Let us take the measurement of time as an example. We measure time by comparing it to certain cycles, or regular repetitions of readily recognizable events. Our day is a cycle of light and darkness, the time it takes for the earth to make a complete turn on its axis. Our month is a cycle, the time it takes for the moon to pass through its successive phases, from one full moon to the next full moon. Our year is an annual cycle, based on the recurring seasons, the time it takes the earth to make a complete revolution in its orbit around the sun. From these cycles, which even primitive man observed, we have the day, month, and year, which are natural divisions of time, but are still comparisons of the flow of time with something else in terms of quantity.

We also measure the weight, length, thickness, and volume of things by comparing them with arbitrary units of measurement. Many standards have been used as units in making measurements: the length of a king's foot, the width of a hand, the weight of a stone, the distance from the equator to the north pole of the earth, the distance that light can travel in a year, but they all employ the idea of comparing an object or quantity with the thing that is being measured.

Instruction

As man's knowledge has increased, the kinds of things that he has found it necessary to measure have become more varied and complex, and the units of measurement that he has devised have become more complex also. The continued use of certain relationships for measuring and expressing quantities has led to standardization, and as a result, basic systems of measurement are now in use throughout the world.

Instructions:

The following questions are based on the questions that the members of the class were asked to prepare. You are asked to decide which of them apply to the basic concept as it is stated above.

First: Read the basic concept over very carefully. You may need to read it again many times while you are taking the test. Do so as often as you wish.

Second: Mark "G" in front of those questions which apply to the basic concept. It would be a good idea to go through the entire list, and mark only those few which you think apply most closely. Then go back through the list a couple more times to find and mark any that you missed before. In this way the first and best ones that you mark will serve as a standard by which you can judge the others.

Third: When you are sure that you have marked all the "G's", go back through the list one more time and mark "X" in front of all the questions that are left.

- X 1. Is the metric system the simplest way to measure anything?
- G 2. What do we mean by "margin of error"?
- G 3. If we had only millimeters, how much measuring would be done of big objects?
- X 4. How does the metric system work?
- X 5. What is volume?
- G 6. If long ago people considered an acre to be one morning's plowing, how would they know it was accurate because people work at different speeds?
- G 7. How would you go about making a system of measurement if there were none?
- X 8. Will the United States eventually change to the metric system?
- G 9. Did anyone ever use a stick for measurement?
- X 10. Why is the metric system easier than the English system?
- G 11. Does physical state have anything to do with the way in which you measure something?
- X 12. Who invented the metric system?
- G 13. How are units of measurement related to whatever it is that you are measuring?
- G 14. How could you measure space?
- X 15. How do you go about learning the metric system?
- X 16. Does the metric system always deal with multiples of ten?
- G 17. What kind of measurement do they use to measure the distance from the earth to the sun?
- G 18. What do volume, weight, and physical state have to do with each other?
- X 19. Does the modern factory worker use a lot of measurement in a day?
- X 20. Why does foam have weight?
- G 21. Can we measure anything without units of measurement?
- G 22. What relationship are we using when we measure time by a sundial?
- X 23. Why has the United States been thinking of changing to the metric system?
- X 24. Why do we speak of the weight of air?
- G 25. Is measurement relative?
- X 26. What did cave men use for measuring?

- G 27. Why would a clock that measures time by atomic vibrations be more accurate than the clocks that we have now?
- X 28. Do we use measurement every day?
- X 29. Could you invent a measuring system easier for all countries to use than the metric system?
- G 30. When you measure something with a ruler, are you comparing it to the ruler itself?
- X 31. Is there a system better than the metric system?
- G 32. When you put a penny in one can and balance it by putting BB's in the other can, is it similar to the way people used to buy groceries by taking a set weight and balancing it with the kind of food they wanted?
- X 33. Why do you have to get the yard stick to balance?
- G 34. What is a foot-pound?
- G 35. Is measurement a system of relating objects to one another?
- X 36. Are there any scales in the world that weigh feathers?
- G 37. Is balance related to measurement?
- X 38. Why do we use a scale?
- X 39. How much does a penny weigh?
- G 40. Does measurement ever express the quality of something by comparing it with something else?
- X 41. Why did we have to make a notch every quarter-inch on the ruler?
- G 42. Could we use weights to measure distance?
- G 43. Does the shaving cream weigh the same in all of its forms?
- X 44. How do the liquid and the gas in the shaving cream turn to foam?
- X 45. If the can has a leak, is it just like getting a leak in the pressurized cabin of an airplane?
- G 46. Is there a means of measuring everything in all different physical states?
- G 47. Could you devise a system of measuring weight with something other than BB's and pennies?
- G 48. Are you in a sense measuring the effect of gravity when you do a weight experiment?
- X 49. How much do fifty pennies weigh?

- X 50. Does this balancing experiment affect our everyday lives when we weigh and balance something?
- G 51. What kind of units are used to measure weather?
- X 52. Do all aerosol devices need shaking?
- G 53. To what extent can we use the same kind of measurement units to measure the shaving cream when it is in the can and after it comes out?
- X 54. How is the pressure built up inside the shaving cream can?
- G 55. Would it be possible to measure the space an electron occupies?
- X 56. What kind of gas, when mixed with a liquid, turns it into a solid?
- G 57. How did man first get the idea to use measurement?
- X 58. Were the measurements that the ancient Greeks and Romans used very accurate?
- X 59. Which king said that three barley grains equaled one inch?
- G 60. Why do people need to measure things?

Test to Determine Your Understanding of the Basic Concept of Tools as Extensions of Man's Body

(Based on laboratory experience: "Extending Man's Body with Tools")

Basic Concept: Within these experiences we will be using the word tool in several different but related ways. In order to understand this term we must clearly define it. A tool is anything which is used to solve a problem, or to meet a challenge posed by a certain situation. It is a device which enables man to adjust to or overcome his environment.

Tools may be thought of as extensions of man's body and its capabilities. From the time of his origin, man has made tools which enable his body to reach outward and do things which it would not be able to do without them. This concept may be expanded to include the outside sources of energy which man uses to operate his tools. As civilization has advanced, tools have become more complex, and greater amounts of energy have been required.

It is this basic ability to make tools which separates man from other animals. As a result of it, he has been able to incorporate the basic tools into complex machines which more effectively extend his body and its capabilities.

Instructions: The following questions are based on the questions that the members of the class were asked to prepare. You are asked to decide which of them apply to the basic concept as it is stated above.

First: Read the basic concept over very carefully. You may need to read it again many times while you are taking the test. Do so as often as you wish.

Second: Mark "G" in front of those questions which apply to the basic concept. It would be a good idea to go through the entire list, and mark only those which you think apply most closely. Then go back through the list a couple more times to find and mark any that you missed before. In this way the first and best ones that you mark will serve as a standard by which you can judge the others.

Third: When you are sure that you have marked all the "G's", go back through the list one more time and mark "X" in front of all the questions that are left.

- X 1. What is friction?
- X 2. Name three kinds of levers.
- G 3. Can you hear a watch tick better with a funnel?
- X 4. What are some simple tools?
- G 5. Is wearing glasses a form of extending man's body?
- G 6. What does mechanical advantage mean?

- X 7. Do you need air to make friction?
- X 8. What are the three parts of a lever?
- G 9. Does man's body extend in using a piece of chalk?
- X 10. What animals use tools?
- X 11. Would a 300 gram weight and a 150 gram weight balance at the same distance apart?
- G 12. Does a book extend man's body?
- G 13. Are computers tools?
- X 14. Are there more complex machines today than 20 years ago?
- G 15. Why would man's tools depend on his environment?
- G 16. Is everything we can see around us (excluding nature) an extension of man's body?
- X 17. Is a lever a simple machine?
- X 18. Will the day come when tools will build houses, roads, cars, and so forth?
- G 19. How does man have an advantage over animals when he uses tools?
- G 20. Is driving a car an extension of man's body?
- X 21. How does man control his body?
- X 22. What are the three kinds of levers?
- G 23. Can man use tools to overcome or change his environment?
- X 24. At what stage of time did man start making his tools complicated?
- G 25. What is man's mechanical advantage when using a lever?
- G 26. When you see how far away you can hear a watch tick, then listen to it through a paper funnel and hear it twice as far away, is this extending your body?
- X 27. Do all pulleys have two wheels?
- X 28. Does fulcrum mean the point at which the stick is suspended?
- G 29. Does your mind use tools?
- X 30. Is man's body used like an animal's body?
- X 31. Is the wheel alone a machine?
- G 32. Is almost everything man uses a tool?
- G 33. Can electricity be an extension of man's body to make him see better?
- X 34. How can a lighter weight balance a heavier one?

- G 35. Is there an extension of man's body to make him see better?
- X 36. Did cave men use tools in ancient times?
- G 37. Would a grocery bag be an extension of man's body?
- X 38. Does friction occur in most simple machines?
- G 39. Do animals such as horses and dogs sometimes act as extensions of man's body?
- G 40. Is a fountain pen an extension of man's body?
- X 41. Are the uses of the wheel any different now than they were in the early 1800's?
- X 42. Could you make a simple machine that would not cause any friction?
- G 43. Is a clock a tool?
- X 44. Does friction operate with wind and water?
- G 45. Is the use of gasoline an extension of man's body?
- G 46. Can man's tools be used for measuring and weighing?
- X 47. Can a four-footed animal use tools?
- X 48. What do the terms fulcrum, effort and resistance mean?
- G 49. In the olden days, milking was done by hand. Are the machines now used for milking extensions of man's body?
- X 50. Could simple machines be used to help us more?
- G 51. In a sense, would I be stronger if I used a lever to lift things?
- X 52. Why can animals do some things that man can't do?
- G 53. How far can man's body be extended?
- X 54. Could you hear through the can-and-string telephone if the string were placed underground?
- G 55. Why are the pointed rooftops of houses in the form of inclined planes?
- G 56. To what extent would man's capabilities be held down if there were no simple machines?
- X 57. Is it possible that you could move the earth if you had a large enough lever?
- X 58. Are we really superior to animals?
- G 59. Could you consider a piece of paper to be an extension of man's body?
- G 60. In a surgical operation, would a knife be an extension of the doctor's body?

Test to Determine Your Understanding of the Basic Concept of Normal Curves, Warping Factors and Sampling

(Based on laboratory experience: "Normal Curves and Warping Factors")

Basic Concept: As the scientist works he discovers certain patterns in nature. These patterns frequently take the form of normal curves. What is meant by the term "normal curves"? In order to better understand the term, let us use an example within our classroom.

If one were to collect a representative sample of the ages of the students in this class, he would find that a great number of them would fall within the same age group, and a few would be above or below. If these data were recorded in the form of a graph, the results would constitute a normal curve. The curve would take the form of a bell-shaped line, the center of which would be the norm, where most of the ages recorded would fall.

Sometimes these curves are modified. This results from what we call "warping factors". For example, if one were playing with dice that were not loaded, and the results of many throws were recorded on a graph, the graph would take the shape of a normal curve. If the dice were loaded, a particular number would be favored. This would obstruct the number that would normally show, and thus would cause a warp in the normal curve.

The scientific procedure employed is also important, because the patterns found are a direct result of the method used and the amount of sampling that takes place. The larger the sample, the better the picture. For example, if we could increase the sample of 7th grade students in relation to age from our class to all 7th graders in the United States, we would have a more valid and dependable result.

Thus we see what a normal curve is, and how it may be modified by warping factors and is dependent on the amount of sampling that takes place.

Instructions: The following questions are based on the questions that the members of the class were asked to prepare. You are asked to decide which of them apply to the basic concept as it is stated above.

First: Read the basic concept over very carefully. You may need to read it again many times while you are taking the test. Do so as often as you wish.

Second: Mark "G" in front of those questions which apply to the basic concept. It would be a good idea to go through the entire list, and mark only those few which you think apply most closely. Then go back through the list again a couple more times to find and mark any that you missed before. In this way the first and best ones that you mark will serve as a standard by which you can judge the others.

Third: When you are sure that you have marked all the "G's", go back through the list one more time and mark "X" in front of all the questions that are left.

- X 1. What are the steps of the scientific method?
- X 2. How do you go about making a normal curve?
- G 3. If you flipped a coin one hundred times, and flipped one a thousand times, would the thousand times be more valid?
- X 4. What steps are taken in solving a problem?
- G 5. Is a normal curve something which happens normally?
- G 6. If you had the ages of all of the 7th graders in Kalamazoo, could you get a general idea of the ages of all of the 7th graders in the United States?
- X 7. Does the way you flip the coin have anything to do with the way it is going to land?
- G 8. Could you make a normal curve with data on the birth rate or death rate of animals?
- X 9. Are normal curves similar to warping factors?
- G 10. What is the probability that fifty heads and fifty tails will turn up if you toss one coin a hundred times?
- G 11. Does a norm have anything to do with a normal curve?
- X 12. How do different coins affect whether it turns up heads or tails?
- G 13. If you were to toss pennies in trying to make a normal curve, how many times would you have to toss them?
- X 14. Why are some pennies and other objects, which are supposed to be equal on the two sides, unequal?
- X 15. How does probability differ from a conclusion?
- G 16. Can a single warping factor throw off a normal curve?.
- X 17. How can you know beforehand how many heads and tails will turn up in an experiment?
- G 18. Would you get better results if you had thirty-two students with six pennies each, or three classes of thirty-two with each student having two pennies each?
- X 19. How did science get started?
- G 20. Would your chances of drawing out one of the four "tens" in a deck of fifty-two playing cards be four out of fifty-two?
- X 21. Name some warping factors in the human brain.
- G 22. Do perfect normal curves occur very often?
- G 23. Which would make a better normal curve, to take ten 7th graders and write down their ages, or to take all of the students in the 7th grade in Kalamazoo?

- X 24. Is flipping a coin an experiment?
- X 25. Why is a question similar to a hypothesis?
- G 26. What is the probability that three tails will turn up if you toss six pennies at once?
- X 27. What gives a scientist the mind to try something over and over that has already been proven?
- G 28. Can normal curves be used in any subject in school?
- X 29. Are warping factors working inside the earth?
- G 30. What is meant when a hypothesis is called an educated guess?
- X 31. What would the hypothesis be if there were 600 trees; how many would be two years old?
- G 32. Does everything have warping factors?
- X 33. What is the probability of an engine turning over in an hour?
- G 34. Why doesn't nature form perfect normal curves?
- X 35. If you dropped two balls, one of iron and one of aluminum, would the iron one hit the ground first?
- G 36. Is there a relationship between natural laws and probability?
- G 37. Are warping factors the only thing that could make tossing pennies not come out 50:50?
- X 38. What is a line graph?
- G 39. Is a tentative solution a probable solution?
- X 40. Can thinking machines think by themselves?
- G 41. What is a natural law, and why is it called a natural law?
- X 42. What are the basic steps you take when you use the scientific method?
- X 43. If you took all the students in your junior high school class, would there be a 50:50 chance of more of them being twelve than thirteen?
- G 44. What is meant by probability when you say, "Is there a probability of man reaching Mars in the next ten years?"
- G 45. Is there a natural law that would solve the problem of losing at a card game?
- X 46. Explain how to make a bar graph.
- G 47. Almost everybody knows what science is; well, most people think they know. Well, suppose no one knew about science; what would you do if you wanted to invent science? How would you go about it?

- G 48. Why in tossing six pennies, do three tails turn up more frequently than any other number?
- X 49. What shape on a graph is a warping factor?
- G 50. How is probability related to chance?
- X 51. Do all results make a normal curve?
- X 52. Is inductive thinking when you start with an answer and try to prove it?
- G 53. Every day Mary gets up, cleans herself up, makes her bed, eats breakfast, goes to school, comes home, cleans her room, eats supper, studies her lessons, and goes to bed. Would you call this a pattern in nature?
- X 54. Is a warping factor the whole normal curve?
- G 55. If we have a larger population, why are the chances greater for whatever we are studying to occur?
- G 56. If you asked 100 children how old they are, and found that 14 were 11 years old, 60 were 12 years old, and 26 were 13 years old, would your results constitute a normal curve?
- X 57. Does scientific behavior center on problems?
- G 58. Are warping factors always at work in the natural world?
- X 59. Are data the same as information?
- X 60. How do we know what an experiment is?

Test to Determine Your Understanding of the Basic Concept of Gradients

(Based on laboratory experience: "A Simple Learning Curve")

Basic Concept: Nature is full of examples of gradients. They are situations which exhibit continuous, progressive change. They are equally characteristic of the physical world and the biological world, including ourselves.

There is a decrease in the average annual temperature as one goes north from the equator to the pole. This progressive decrease constitutes a gradient of temperature. A stream exhibits a gradient of decreasing elevation from its source to its mouth. This is why the water flows downstream.

The process of learning shows a gradient of increasing skill, and is basically the same in all animals, regardless of species. In your own studies, the skills that you try to accomplish, and the knowledge that you try to acquire, are improved by repetition, by going over them again and again.

In order to observe this learning process in ourselves, we can record the degree of improvement, which is really learning activity, in the form of a line on a graph, and thus obtain a gradient. We can use an experience of this kind to explore the idea of gradients.

Instructions: The following questions are based on the questions that the members of the class were asked to prepare. You are asked to decide which of them apply to the basic concept as it is stated above.

First: Read the basic concept over very carefully. You may need to read it again many times while you are taking the test. Do so as often as you wish.

Second: Mark "G" in front of those questions which apply to the basic concept. It would be a good idea to go through the entire list, and mark only those few which you think apply most closely. Then go back through the list again a couple more times to find and mark any that you missed before. In this way the first and best ones that you mark will serve as a standard by which you can judge the others.

Third: When you are sure that you have marked all the "G's", go back through the list one more time and mark "X" in front of all the questions that are left.

- G 1. How are normal curves related to gradients?
- X 2. Is a chalk board an example of a gradient?
- G 3. Would a road going down a mountain into a valley constitute a gradient?
- X 4. If a person were copying someone else's paper, would that be a learning curve?
- X 5. Would measuring be a form of gradient?

- G 6. The first time we worked the puzzle it was hard, but the second time it came easier; is this basically the same as when a baby starts to walk, the first time it is hard, but the second and third times it comes easier?
- X 7. Could we make a normal curve as to how rapidly different classes adapt to a new puzzle?
- X 8. Scientists have used the monkey in experiments and in space; is it true that the monkey is the closest animal to man?
- G 9. Would a path going down a hill and a learning curve both mean gradient in general?
- G 10. An airplane is getting ready to land; when it begins to lose altitude would that be a gradient?
- X 11. Would the number of people in the United States in 1968 be a gradient?
- X 12. What are some examples of how gradients are used?
- G 13. Do gradients have anything to do with the growth of a child?
- X 14. In the experience we did, some people said it took them longer to do the puzzle the second time than it did the first time; what is one reason why it could have happened this way?
- G 15. Is a gradient the process by which something ascends or descends?
- X 16. Do the pieces of the puzzle in this experience have to be triangular?
- G 17. A boy got a bicycle; the first day he could ride three blocks, the next day five, and the next ten without falling off; could this be an example of a gradient?
- G 18. How can you learn from books, because in learning to do the puzzle we had to do it over and over, but when you read a book you don't usually read it over and over?
- X 19. Does the age of a person make any difference in putting the puzzle together?
- X 20. Would a man or any other animal learn faster without using words?
- G 21. How does the growth of a blade of grass constitute a gradient?
- X 22. Are learning curves very accurate?
- G 23. Can gradients be used in a comparison between two things?
- X 24. Did the number of parts in the puzzle make any difference in the length of time it took us to learn it?
- G 25. A pencil when it is sharpened tapers toward the tip; is this a gradient?
- X 26. If Tom can put the puzzle together faster than Dick, does this mean that Tom is smarter than Dick?

- X 27. Would all of the puzzles take the same time to put together, even if they weren't all cut alike?
- G 28. Does the yearly increase in manufacturing in the United States for the last ten years constitute a gradient?
- G 29. How are gradients related to the weather?
- X 30. Why do you have to reduce a problem to its simplest terms before trying to solve it?
- G 31. Is the growth of a tree recorded over a period of twenty-five years a gradient?
- X 32. Why would it get colder going north?
- G 33. Is the amount of sunlight received at a place within the Arctic Circle during a season a gradient?
- X 34. If you went east and west along the equator, why would it stay the same temperature?
- X 35. Can a learning curve be used every day and at any time or place?
- G 36. What is an inclined plane; is it a gradient?
- G 37. If you took the number of children in sixth grade in the United States each year for the last ten years and plotted the numbers on a graph, would this constitute a gradient?
- X 38. Would the number of shaves you can get with a Gillette Superblade be an example of a gradient?
- X 39. Is this a gradient: cold weather and high winds?
- G 40. If you took a test one day, and then took the same test again the next day, would you be likely to get more right the second time?
- X 41. If other animals had minds like we humans have, would they be able to work the puzzle faster or slower than we did?
- G 42. Could changes in the water level of the Great Lakes be expressed as a gradient?
- G 43. Would a gradient apply to your height each year from the time you are two years old until you are twelve years old?
- X 44. Could anyone learn to do anything in less than three seconds?
- G 45. Is the incline of a hill a gradient?
- X 46. Would people react differently in putting different kinds of puzzles together?
- G 47. If you got so you could do the puzzle in a very short time, and then waited a week, could you still do it just as fast?
- G 48. When a river flows, why is the gradient decreasing?

- X 49. Does this experience prove how much intelligence we have?
- X 50. Will this experience affect our everyday lives in the future in figuring out the answers to our problems?
- G 51. Why is it that the more times we put a puzzle together, the faster we can do it the next time?
- X 52. When a scientist sets out to study a problem, does he always use gradients?
- G 53. Why is it normal that your last trial usually takes the shortest time?
- X 54. Why does it get colder in the north than in the south?
- G 55. After you came to know the puzzle real well, why was it that the time for putting it together sometimes increased rather than decreased?
- X 56. Why are some people more skilled than others?
- G 57. If a person is learning to do something, would a record of his errors constitute a gradient?
- X 58. Can a person learn in any other way than by repeating a process over and over?
- X 59. How is time related to normal curves?
- G 60. Are learning curves and gradients the same thing, or do they just seem to be alike?

Test to Determine Your Understanding of the Basic Concept of
Directional Change in Response to the Challenge of the Environment

(Based on laboratory experience: "Directional Change in the Human Species, the Long Line," together with a field trip to the Chicago Museum of Natural History and class discussion.)

Basic Concept: The idea involved in an understanding of evolution can be stated rather simply: Variation, plus the survival of that which "works," results in evolution.

Evolution is the process of change, change in plant and animal forms, change in the physical world, and change in the social world of habits, customs, ideas, beliefs, what man does, and the things he has invented and uses. It is the continuous adjustment of anything to the demands of a changed or changing environment.

Evolution results from a combination of two of the basic behaviors which scientists have found to be general properties of nature. They have learned to expect nature to show variation and change. They have also learned that in nature that which "works" survives and tends to perpetuate itself (or be perpetuated), rather than that which does not "work", or that which "works" less well. When variation and change interact with survival and perpetuation, whether in biological nature, physical nature, or the various modifications and applications of nature that man has made, evolution, generally in the form of directional change, is the result.

Instructions: The following questions are based on the questions that the members of the class were asked to prepare. You are asked to decide which of them apply to the basic concept as it is stated above.

First: Read the basic concept over very carefully. You may need to read it again many times while you are taking the test. Do so as often as you wish.

Second: Mark "G" in front of those questions which apply to the basic concept. It would be a good idea to go through the entire list, and mark only those few which you think apply most closely. Then go back through the list again a couple more times to find and mark any that you missed before. In this way the first and best ones that you mark will serve as a standard by which you can judge the others.

Third: When you are sure that you have marked all the "G's," go back through the list one more time and mark "X" in front of all the questions that are left.

- G 1. How do animals adapt to changes in the environment?
- X 2. Could man's and monkey's ancestors have been brothers many years ago?
- G 3. Can the intelligence of animals be controlled by selection?
- X 4. Why are only some animals domesticated?
- X 5. Why hasn't man's physical appearance changed as much as that of the horse?
- G 6. Once a mutation occurs, how can it develop into a permanent evolutionary change?
- G 7. If a mutation improves the survivability of an organism, will natural selection preserve this new trait?
- X 8. Can a variation be successful if it is not hereditary?
- G 9. Does the climate of a region select those variations which are best adapted for survival?
- X 10. Why is man believed to be developed from prehistoric animals such as the lemur?
- G 11. Could the extinction of the dinosaurs have been due to their inability to change to adjust to the environment?
- G 12. By looking at the past and the present variety of man, is it possible to predict what natural selection will make out of man in the future?
- X 13. Is man unique when it comes to proxy evolution?
- X 14. Did humans evolve from the one-celled protozoa?
- G 15. Is time a strong determining factor along with variation and selection as far as directional change is concerned?
- X 16. Was the elephant skin we touched in the museum the same as it was on prehistoric elephants?
- G 17. What effect has environment had on the evolution of man in various geographic regions of the world?
- G 18. If all woodpeckers were placed in a woodless environment, over a long period of time, would they be able to adjust?
- X 19. Do wild plains horses have longer legs than domesticated horses?
- X 20. Does a person bear any of the characteristics of his ancestors, say six generations back?
- G 21. Is there any prospect of science being able to help the evolution of man in the future, by controlling his environment?

- X 22. Is it possible for us to think that 200 years from this era, the toes and fingers of human beings will be changed, due to the development of scientific technology?
- G 23. Considering the wide variation in present-day mankind, could another race of man develop through natural selection from existing human types?
- X 24. What kinds of variations are found in the five major present-day human races?
- G 25. Does the force of natural selection act upon variation to encourage favorable gene combinations and eliminate unfavorable ones?
- X 26. Is mutation the result of natural selection?
- G 27. Is selection the only force acting on variation to produce evolutionary change?
- X 28. Is perspiring in human beings, to maintain body temperature at a constant level, an environmental adjustment?
- G 29. Does selection mold the spectrum of variation into new patterns of adaptation in a continuously changing environment?
- X 30. How can the white-eye allele in Drosophila melanogaster be accounted for?
- G 31. Is the evolution of tools caused by environmental selection operating on a variety of forms?
- G 32. Is industrial melanism a form of evolution?
- X 33. What is the difference between microevolution, macroevolution and megaevolution?
- X 34. Is it possible for a single human line to arise in the future?
- G 35. Does all life evolve or simply die out when it cannot adjust to the environment?
- G 36. Is natural selection a creative force in evolution since it favors and encourages efficient gene combinations?
- X 37. What changes have taken place in man's bone structure during his evolutionary development?
- X 38. Did the different races of man evolve separately or did they all arise from the same stem?
- G 39. Is the force of natural selection the impact of the total environment on the reproduction of gene combinations?
- X 40. Is gene mutation a change in the chemical organization of the gene that is replicated and passed on to succeeding generations?

- G 41. Are evolutionary changes still taking place in man?
- G 42. Is the rate of evolution more rapid in tropical areas?
- X 43. In what way did the different races of man first start?
- X 44. Is it true that hair is becoming unnecessary to man, and will gradually become extinct?
- G 45. Can a large mutation in an animal cause another animal to destroy it because it is different?
- G 46. What forces led to the selection of those variations that caused animals to evolve into man?
- X 47. How much effect do man's actions have on changing the world around him?
- X 48. Does evolution occur in all living matter?
- G 49. How does climate affect variations in a species?
- X 50. Is the law of probability involved in the evolutionary process?
- G 51. Don't climate and environment have a lot to do with what kinds of animals and plants survive?
- X 52. Will our generation witness evolution in the development of the physical characteristics of man?
- G 53. How did environment affect the development of the races of man?
- X 54. Is evolution evident in micro-organisms?
- G 55. Is man shaping his present environment to fit himself or is he shaping himself to fit his environment?
- X 56. If man has not yet completed his evolutionary cycle, will future changes be good or bad?
- G 57. Is survival of the fittest still taking place in man now that science and medicine have found ways of getting around man's deficiencies?
- X 58. Is man really a descendant of an ape?
- X 59. Has there been or will there ever be a retrogressive form of evolution?
- G 60. If man establishes a colony on Mars, and lives there for 100 generations, will his descendants be able to interbreed with humans back on earth?

***Test to Determine Your Understanding of the Three Basic Concepts or Ideas**

Instructions: The following three groups of twenty questions each, were taken from the list of questions that the members of the class were asked to prepare. You are asked to judge which ones apply to the basic concept as it is stated.

First: Read the basic ideas over very carefully.

Second: Mark "G" for "Good" in front of those questions which apply to the basic idea. It would be a good idea to go through the entire list, and mark only those few which you think most clearly apply. Then go back through the questions again and mark any that you missed before. In this way, the first and best ones that you mark will serve as a standard against which you can judge the others.

Third: When you are sure that you have marked all of the "G's", go back through the list one more time and mark "X" in front of those questions which do not apply to the basic idea.

Basic Concept or Idea: There are no sharp boundary lines in nature. All gradients show continuous change in one direction. There are gradients of increase and gradients of decrease.

This portion of the test was based on the laboratory experiences on "Paper and Thin Layer Chromatography," and "Yeast Activity."

- G 1. Would a gradient result in a bucket of water under a dripping faucet?
- X 2. What is the most common gradient?
- X 3. How do you find a gradient?
- G 4. Is it a gradual change when a twig is being burned?
- X 5. Is it interesting to study deep into a gradient?
- X 6. What does a gradient do?
- G 7. Is there a gradient in your weight as you grow?
- G 8. Would there be a gradient from the evaporation of water in a bucket of water in heat all day?
- X 9. What is an example of a gradient?
- X 10. In what cases would a gradient be wrong?
- X 11. How are gradients made?

*This test was prepared by Miss Phyllis Carnes, University of Georgia, Athens, Georgia.

- G 12. How far can a gradient rise?
- G 13. Can the gradient be measured by pounds, carrots, ounces, or anything else besides centimeters and millimeters?
- G 14. Can the environment change a gradient?
- X 15. Who invented the gradient?
- X 16. Can gradients help you in science?
- X 17. Why is a gradient important?
- G 18. I wonder if you could predict how high a color would rise on filter paper.
- G 19. How long would a gradient keep on going?
- G 20. If we had the amounts of blood cells in different peoples' blood would it form a gradient?

Basic Idea of Normal Curves and Sampling: As the scientist works, he discovers certain patterns in nature which frequently take the form of normal curves. Sometimes these are modified curves which are the result of warping factors. The scientific method employed is also important, because the patterns found are a direct result of the type of method used and the amount of sampling which takes place.

This portion of the test was based on the laboratory experiences on "Use of Normal Curves in Distinguishing Species," and "Normal Curves Describe Variation in Nature."

- G 21. Do you only get normal curves with plants or could you measure the length of a group of children's pencils at the end of a week?
- G 22. When you graph any human characteristic is it possible to have a perfect normal curve?
- G 23. Isn't a graph the best way to see if you have a bell-shaped curve?
- X 24. What language is usually used in classifying plants?
- G 25. Are there any populations exactly alike?
- G 26. When you have a warping factor, is there a mode?
- X 27. Why is measuring leaves important?
- X 28. What does an overlap look like?
- G 29. Is it possible to measure a hundred of something and not have any sign of a normal curve?
- X 30. Do all leaves have a certain pattern?

- X 31. In a class with students' heights between four feet and six feet, who would you pick as a sample?
- G 32. If you measured 1000 lima beans would you have a better curve than with 100?
- X 33. What type of graph do you use most?
- G 34. Why do different graphs of the same species have different norms?
- X 35. Where do most graphs make their peak?
- G 36. Was the only purpose in measuring these things to see how it formed a bell-shaped curve?
- X 37. Does Chinese elm belong to the same genus as the American elm?
- G 38. Can warping factors be good and helpful as well as bad and harmful?
- G 39. If you measured the height of one-hundred people would you get a normal curve?
- X 40. Who started science?

Basic Concept
or Idea:

Measurement was very important in the past and has not changed in respect to our present day society. Since earliest times, measurement has always consisted of an expression of the relationship of one quantity to another. Continued use of certain relationships, however, has led to standardization; as a result basic systems of measurement are now in use throughout the world.

This portion of the test was based on the laboratory experience "A Simple Balance."

- G 41. Is weighing done with quarter-inches and BBs very accurate?
- X 42. What does standard measurement have to do with units of measurement?
- G 43. Are old sayings an accurate way to measure or compare things?
- X 44. Why should each kind of part in a scale be uniform?
- G 45. Is a bucket full a very accurate measurement?
- X 46. What do you think is the best measurement?
- X 47. What is the best measurement for measuring long distances?
- X 48. Why is a correction factor necessary?
- G 49. How can a measurement express a thought?
- G 50. If there were only meters how much measuring would be done on small objects?
- X 51. Why did we have to move the cans up every time we added BBs?

G 52. Could we have used rocks in weighing instead of BBs?

G 53. Can we measure the length of leaves to get a quantity?

G 54. Can we compare measurement with a standard?

X 55. What is the reason that we use the multiples of ten in measurements?

X 56. Why should you put the main string through the 18-inch mark and not the 16 or 17-inch mark?

G 57. Why do you think when you are measuring BBs in cans that when you have the same number of BBs in each can, they do not balance?

G 58. Is spreading your hands out with your thumbs touching each other a good way to measure a foot?

G 59. What does standard measurement have to do with a ruler?

X 60. How did the metric system originate?